

RIFTEK
Sensors & Instruments



3D LASER MEASUREMENT MACHINE

RF1010SL Series

User's manual

info@riftek.com
www.riftek.com

Contents

1.	Safety precautions	3
2.	Electromagnetic compatibility	3
3.	Laser safety.....	3
4.	General information	4
5.	Structure and operating principle.....	4
6.	Basic technical data	5
7.	Dimensions	6
8.	Mounting and setup	6
9.	Connection diagram	8
9.1.	Signal block.....	8
9.1.1.	Connection diagram.....	8
9.1.2.	LED indication	9
9.1.3.	Interface cables.....	9
9.1.4.	Input-output circuitry	9
10.	Software	10
10.1.	Scanning Control	10
10.1.1.	Machine Control	10
10.1.2.	Calculations.....	11
10.1.3.	Input tolerances and setting calculation parameters.....	13
10.1.4.	Logging events and results	14
10.1.5.	Calibrating the machine.....	14
10.2.	Detail statistics viewer.....	15
10.3.	Signal block testing application	15
11.	Intended use	16
11.1.	Preparation for use	16
11.1.1.	External inspection.....	16
11.1.2.	Set up on a conveyer	16
11.1.3.	Switching the machine.....	16
11.1.4.	Calibrating the machine	16
11.1.5.	Checking the machine	16
11.2.	Operating the machine.....	17
12.	Maintenance.....	17
12.1.	General instructions	17
12.2.	Safety precautions	17
12.3.	Maintenance procedure	17
12.3.1.	Daily maintenance work.....	17
12.3.2.	Weekly maintenance work.....	17
12.3.3.	Yearly maintenance work	17
12.4.	Operability test	17
13.	Routine repairs.....	18
14.	Warranty policy	18
15.	Distributors	18

1. Safety precautions

- Use supply voltage and interfaces indicated in the machine specifications.
- In connection/disconnection of cables, the machine power must be switched off.
- Do not use machine in locations close to powerful light sources.
- To obtain stable results, wait about 20 minutes after machine activation to achieve uniform scanner warm-up.
- Avoid metal chips getting into the machine body.
- Do not allow foreign objects to get between moving and stationary parts of the measuring machine after turning it on.
- Do not obstruct the movement of moving parts of the machine.
- Friction parts of the ball screw assembly should be kept clean and be lubricated.
- The machine should be grounded and connected to ground line via a separate lateral line.

2. Electromagnetic compatibility

The machine has been developed for use in industry and meets the requirements of the following standards:

- EN 55022:2006 Information Technology Equipment. Radio disturbance characteristics. Limits and methods of measurement.
- EN 61000-6-2:2005 Electromagnetic compatibility (EMC). Generic standards. Immunity for industrial environments.
- EN 61326-1:2006 Electrical Equipment for Measurement, Control, and Laboratory Use. EMC Requirements. General requirements

3. Laser safety

The machine makes use of laser scanner. Laser scanner belongs to the 2M laser safety class according to IEC 60825-1:2007.

The scanner makes use of an c.w. 660 nm wavelength semiconductor laser. Maximum output power is 8 mW. The following warning label is placed on the laser body:

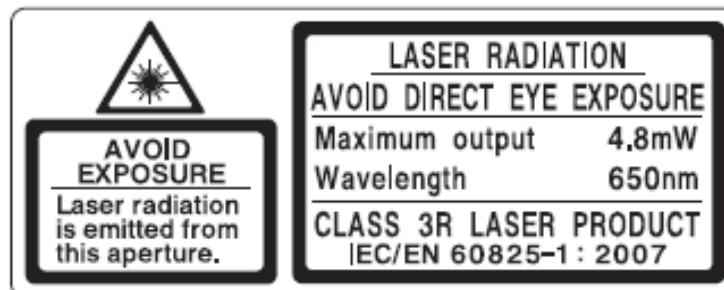

The following safety measures should be taken while operating the scanners:

- Do not target laser beam to humans;
- Avoid staring into the laser beam through optical instruments;
- Do not disassemble the laser scanner;
- Do not place any objects that can cause reflection on the path of the laser radiation.

4. General information

The measuring machine is designed for non-contact measurement of geometrical parameters of objects, specifically suspension arms, and is a standalone software/hardware system.

Technical characteristics of the machine can be changed for a specific task.

5. Structure and operating principle

The work of the machine is based on the principle of 3D laser scanning of object/objects with subsequent construction of a 3D computer model and determination of geometrical parameters from the model.

The machine structural design is illustrated in Figure 1 (machine with cover removed).

The machine comprises two columns 1,2, closed with the guide 3. The carriage 4, carrying the laser scanner 5, is mounted on the guide 3. Mounted on the column 1 the stepping motor 6 is connected to the ball screw (not shown) that drives the carriage 4. In the extreme positions of the carriage 4 limit switches (not shown) are mounted. There are a signal block 7 and a power supply 8 on the column 2.

Laser scanner 5 radiation is formed in a line and is projected onto the controlled object 9. The resulting image of the contour (cross-sectional profile) 10 of the object is analyzed by a signal processor of the scanner which calculates the distance to the object (Z coordinate of points) for each of a plurality of points along the laser line on the object (X coordinate of points).

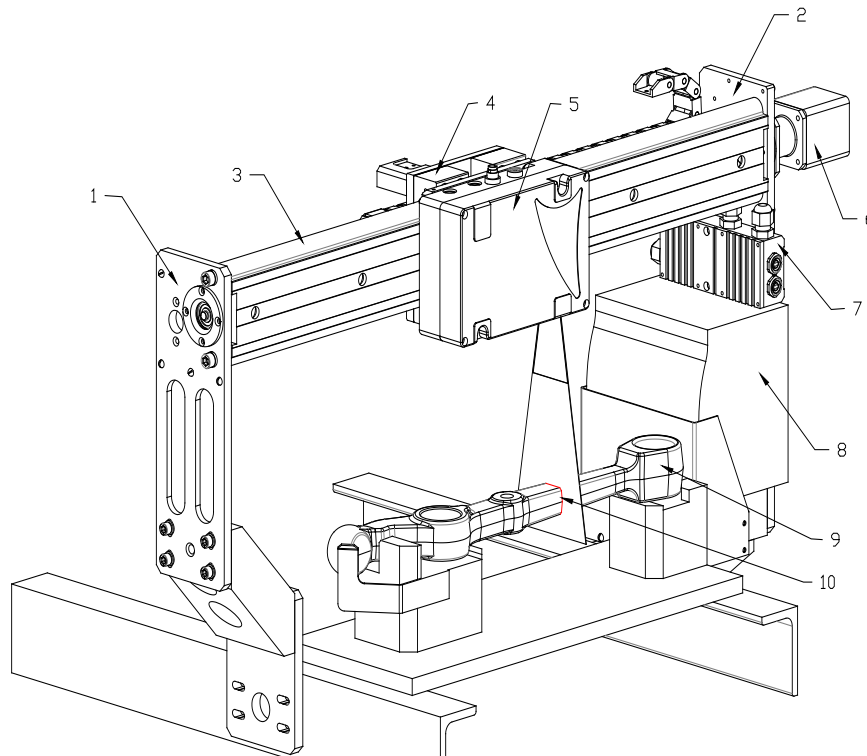

Figure 1

The machine operates as follows.

The laser scanner mounted on the carriage moves along the object, the direction of the movement being the coordinate Y. The laser scanner determines the coordinates of the object profile points (X, Z) at fixed regular linear intervals along the Y coordinate defined by the stepper motor drive, fig. 2.

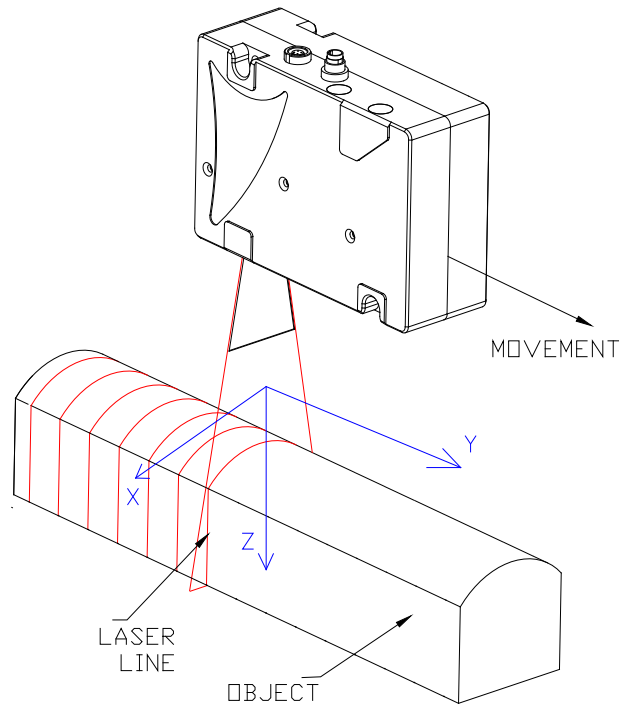

Figure 2

The result is a 3D computer model of the object in the form of Point Cloud with established profile coordinates (X,Y,Z). An example of the model is shown in Figure 3. The required geometrical parameters are calculated from the resulting object model.

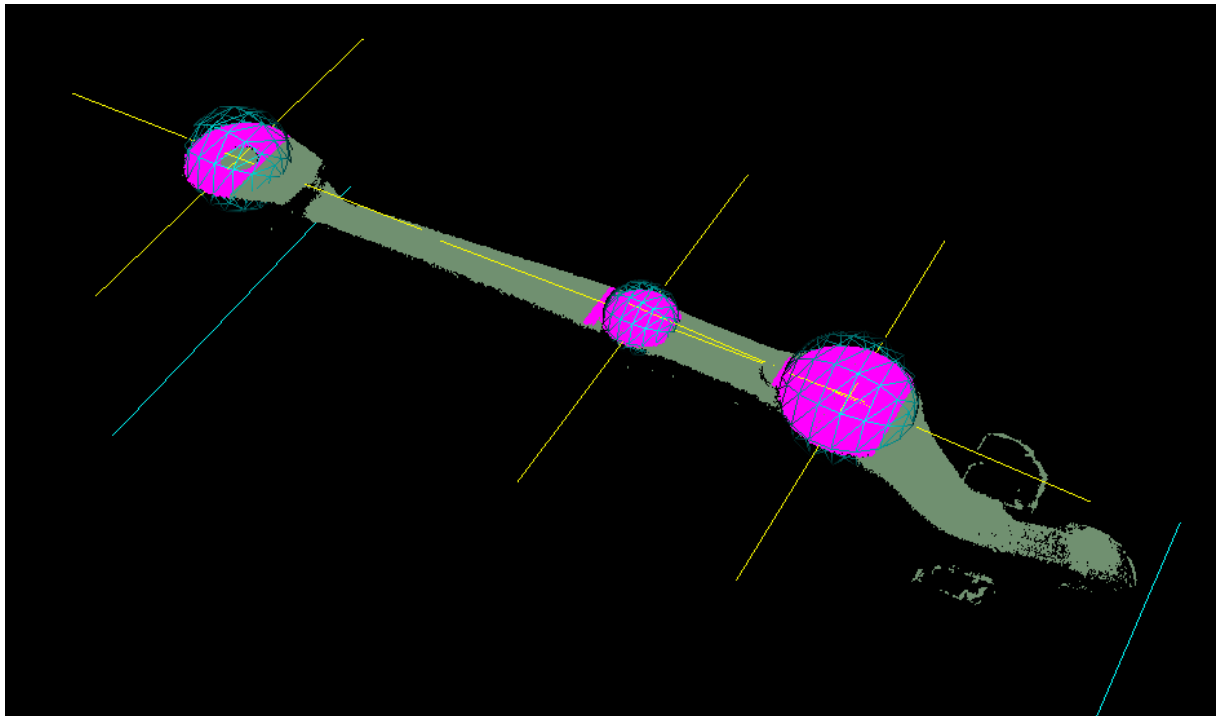

Figure 3

6. Basic technical data

Parameter	Value
Scanning range Y-axis, mm	370
Scanning range, Z-axis, mm	135
Scanning range X (start of measurement, Z-axis), mm	45
Scanning range X (end of measurement Z-axis), mm	70

Measurement accuracy, X,Z axes, um	±50
Measurement accuracy, Y axis, um	±20
Sampling rate, profiles/s	250
Speed, mm/s	
Parameters under control	see point 10.1.2.
Dimension, mm	730x415x180
Weight, kg	40
Power supply	alternating-current mains with sampling rate (50 ± 1) Hz, nominal power 220 with allowable stress ±10 %.
Power consumption, W	300
Environment conditions	Environment temperature: +1...+35°C Relative humidity 25-65%

6

7. Dimensions

The dimensions of the machine are shown in the figure 4.

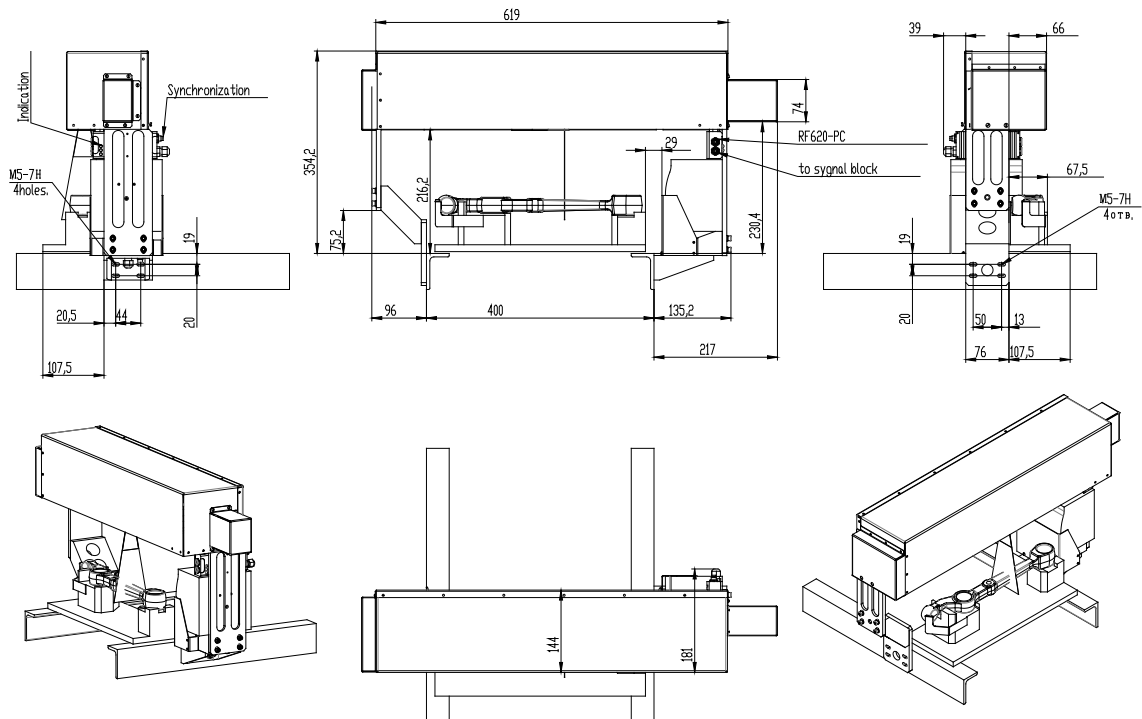

Figure 4

8. Mounting and setup

To reduce the volume of adjustment work measuring machine is delivered fully assembled.

Installation of the machine on a conveyor belt is made as follows.

In the conveyor frame screw holes (M5-7H) are made as per the scheme. Marking the holes is made from pallets, located in the measurement area, according to the figures 5 and 6.

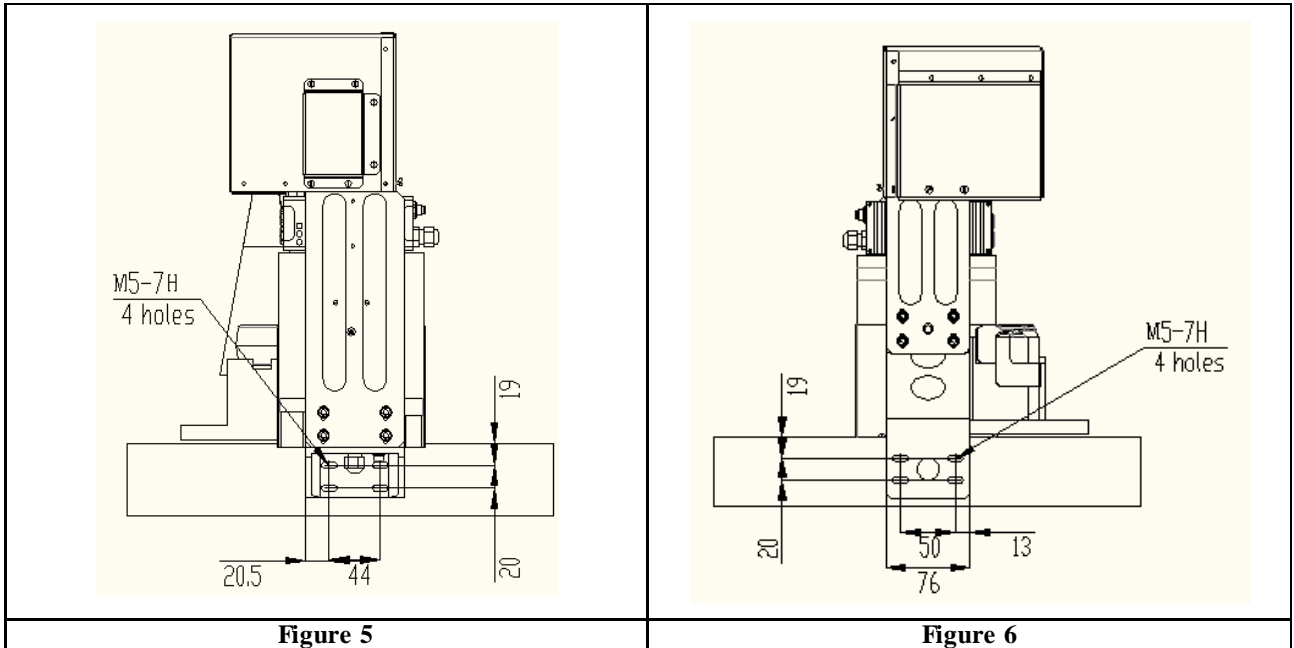

At the measuring station mounting screws are loosened, providing horizontal motions of the support bracket, fig. 7,9.

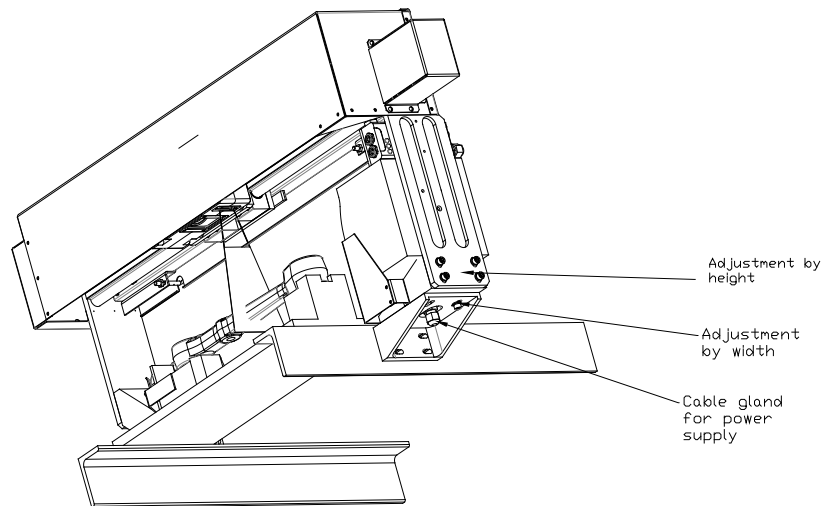

Figure 7

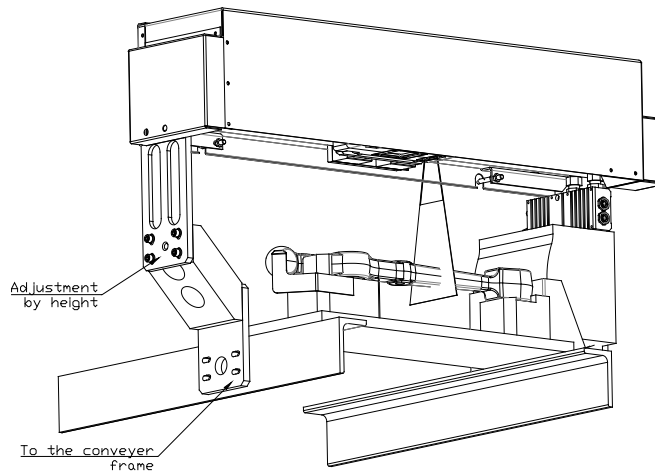

Figure 8

Next is the station installation on the conveyor frame using M5 screws. After the station is installed it should be located at the distance from the conveyor according the installation dimensions, figure 4.

9. Connection diagram

Connection diagram is shown in Fig. 9.

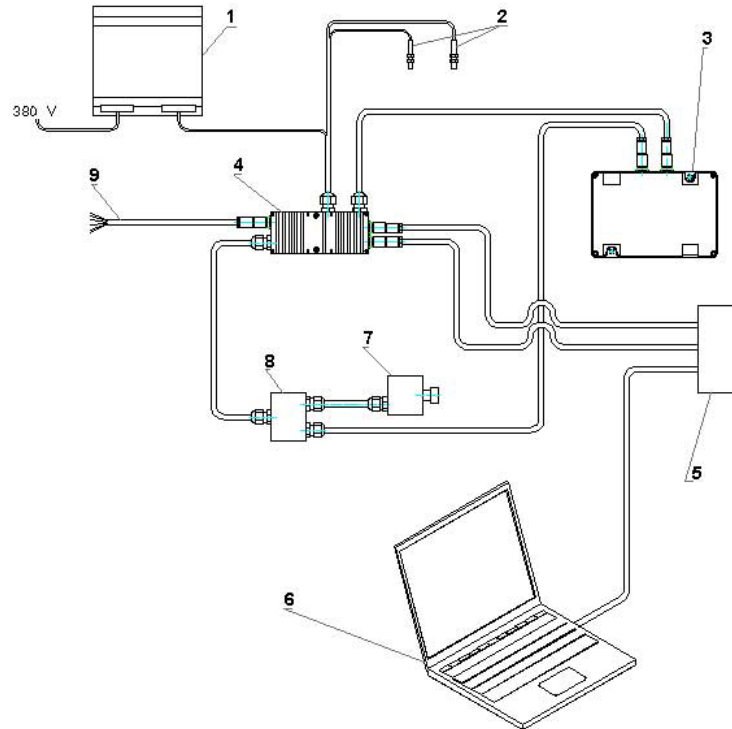

Figure 9

Where 1 – power supply; 2 – limit switches; 3 – laser scanner; 4 – signal block; 5 – network router; 6 - terminal (PC); 7 – stepper motor; 8 – switching unit; 9 – synchronization and signaling machine condition cable.

9.1. Signal block

All interface connections to the machine are implemented via the signal block. 3 LEDs duplicating digital output status are located on the panel of signal block.

9.1.1. Connection diagram.

Connection to signal block is shown in Figure 10.

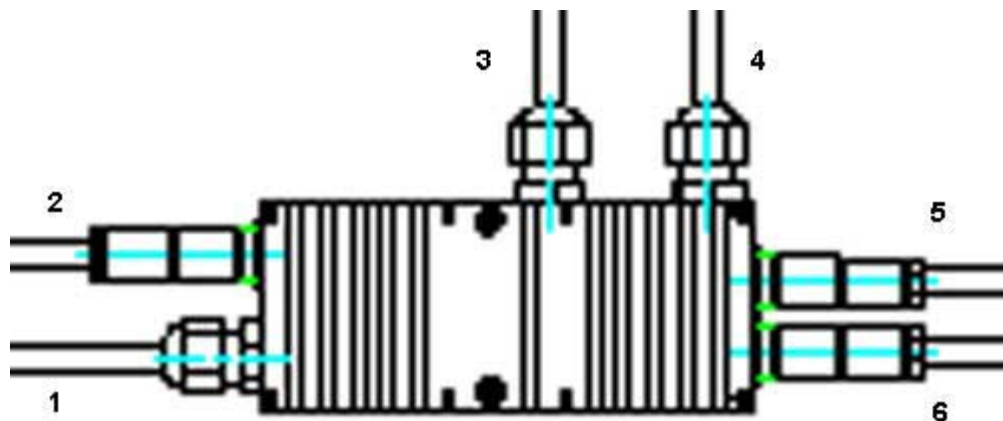

Figure 10

Where 1 – stepper motor to laser scanner connection (cable entry); 2 - synchronization and machine condition digital outputs connection; 3 – power and limit switches connection (cable gland); 4 – network interface of the laser scanner connection (cable gland); 5 - network interface to the router scanner connection (connector); 6 – signal block network interface to the router connection (connector).

9.1.2. LED indication

LED indicators, located on the signal block characterize the current state of the measuring machine and the result of measurement:

Machine condition	Indication
System is ready	Green
Measurement process	Yellow
Failure	Red
Valid detail	Flashing green
Rework	Flashing yellow
Waste	Flashing red

9.1.3. Interface cables

System signals cable 9 is shown in the Figure 11.

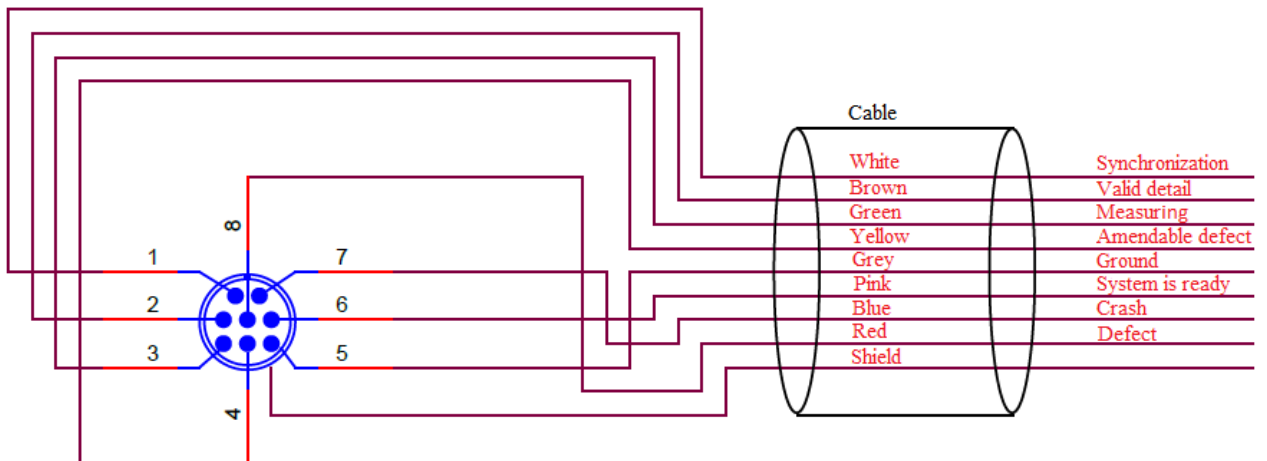

Figure 11

Laser scanner connection cable is shown in the Figure 12.

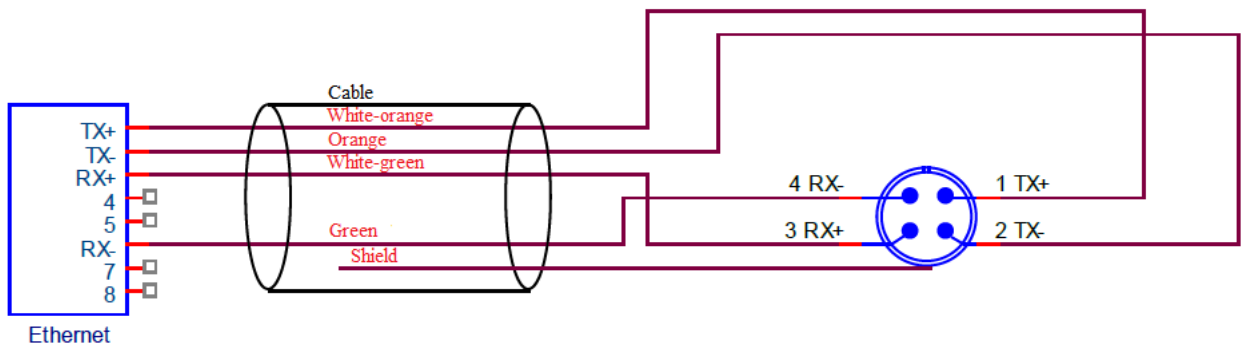

Figure 12

9.1.4. Input-output circuitry

Trigger input stage is shown in Figure 13. Synchronization input is designed to alarm of object on the measuring position.

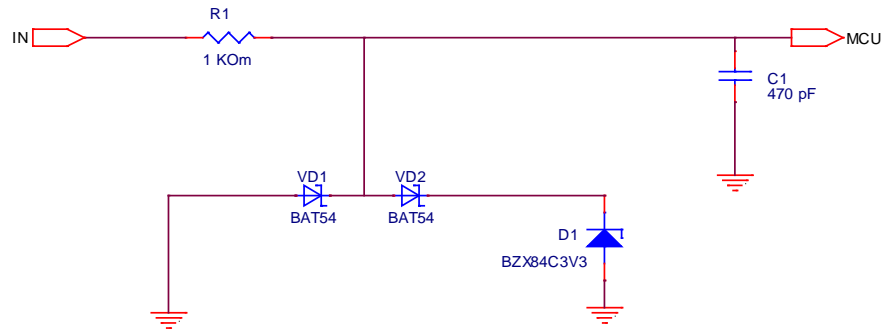

Figure 13

The output stage of the machine condition output is shown in the Figure 14. The outputs are used to connect external alarm and actuators.

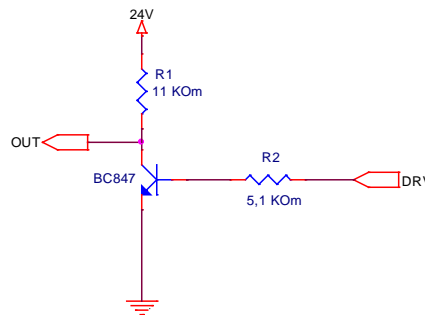

Figure 14

10. Software

The software is implemented to run on the operating system Windows XP, Vista, 7. Qt-library version 4.8.0 Microsoft redistributable package 2010 is used in the software.

Software consists of 4 components:

- Scan control RFScanDetail.exe,
- Statistics details viewer RFStatViewer.exe
- Signal block testing TestSignalBlock.exe
- Scanner setup and test rf620et-sp.exe

Additional applications that may be needed to set up and debug the scanner:

- Wireshark network analyzer
- DHCP server

10.1. Scanning Control

The scanning control application provides:

- control of the machine in working process and debug modes
- receiving data from scanner and three-dimensional detail model construction
- detail model mathematical calculation
- input tolerances and setting calculation parameters
- assessment of detail state and comparison with tolerances
- logging events and results
- machine status control
- signal block management
- calibration of the machine

10.1.1. Machine Control

Operating window of the application is shown in the figure below. Control buttons are located in the right part of the window.

Being started the application automatically searches for the devices of the measuring machine in the network and connects to them. If the devices aren't connected to the network when the application is started, the process can be started forcedly by pressing the **Connect** button.

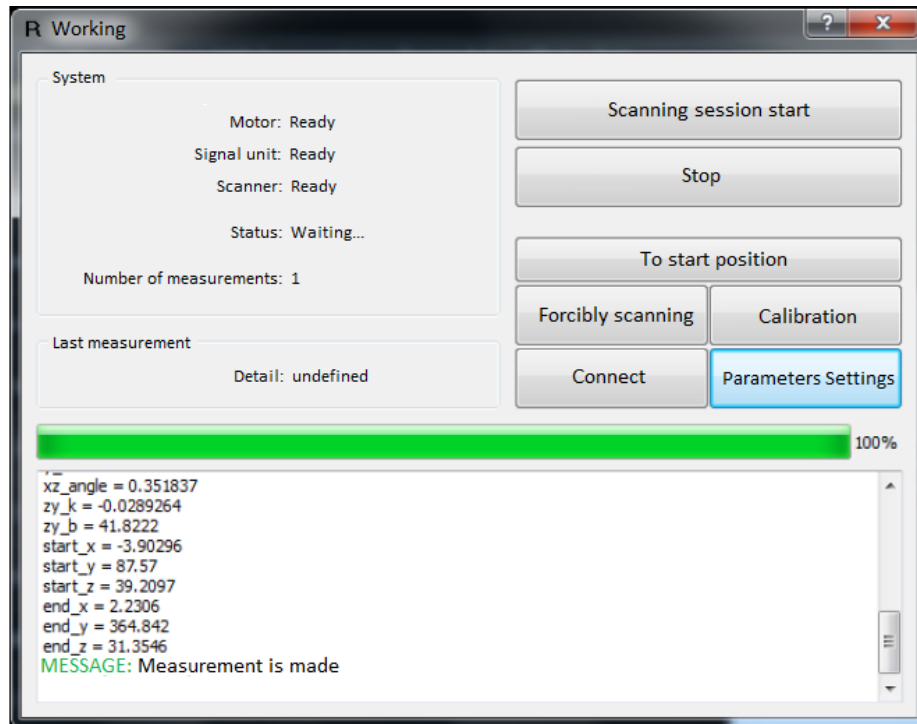

If all the devices are found, the scanning session starts automatically. Scanning session can be stopped via pressing the **Stop** button.

The machine state is displayed in the title bar of the application: **Working** - scanning session is started, **Stopped** - scanning session is stopped. If the session is stopped the measuring process can only be started forcedly from the app via the **Forcibly scanning** button.

The scanning session can be started again via the **Scanning session start** button.

When the scanning session is disabled the system calibration can be performed via the **Calibration** button.

Measurement parameters can be configured at any time while the application is working via the **Parameters Settings** button. But the changes will take effect only after restarting the application.

The basic devices (namely, scanner movement drive, signal block, laser scanner and counter of measured items) status is displayed in the central part of the window.

In the bottom part of the window the calculation results of the last scanned detail and validity evaluation (namely, valid, spoilage and rework) are displayed.

10.1.2. Calculations

The scanning control application performs the next set of calculations:

- Calculation of the axis displacement in the XY-plane as

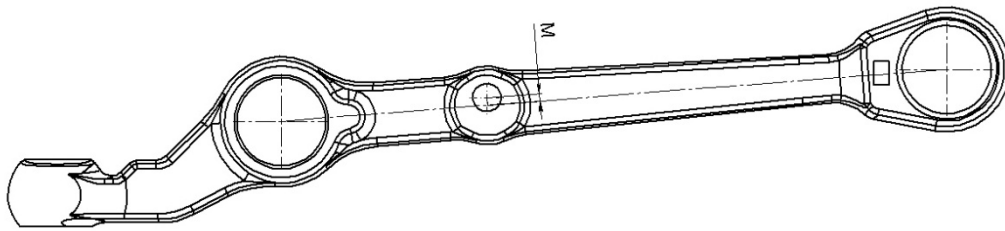

deviation of the central elbow axis position from the axis connecting centers of the two extreme elbows, mm.

- Calculation of the axis displacement in the XZ-plane as

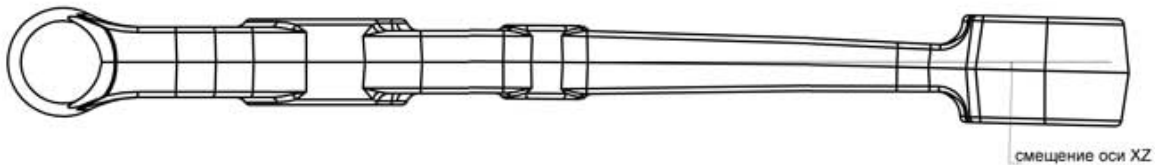

maximum angle (in degrees) between the lines that run along the upper landing of the three elbows,. That is, the angle difference is calculated pairwise between the three lines taken. Displacement of the axis is the maximum difference of the angles.

- Detail width calculation in A,B and C positions

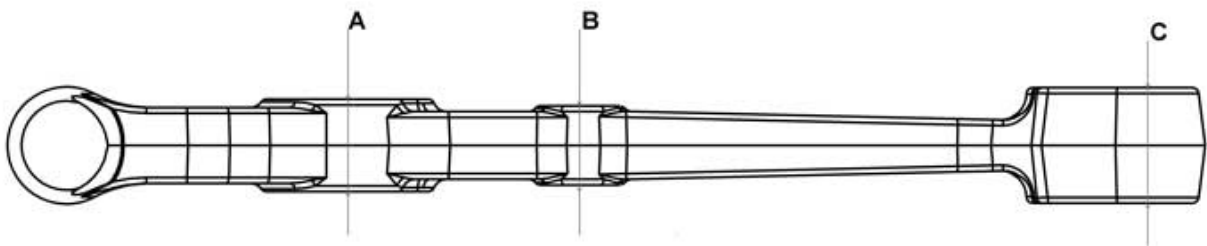

Detail width in A and C positions is calculated according to the calibration data. The calculation is based on the line passing through the center of the visible part of the calibration block. The height of the A and C elbows is compared with the height of the calibration block at A and C points. Then from the nominal value of the calibration standard height the difference between the elbow height and the calibration standard height is subtracted. The obtained result is the elbow height.

The elbow width in B position is calculated on the basis of the widths of the elbow A and C. The central axis of the detail is reproduced on the basis of the A and C widths. The width of the elbow B is calculated from the central axis and the height of the elbow B.

- Distances AB, BC and AC calculation

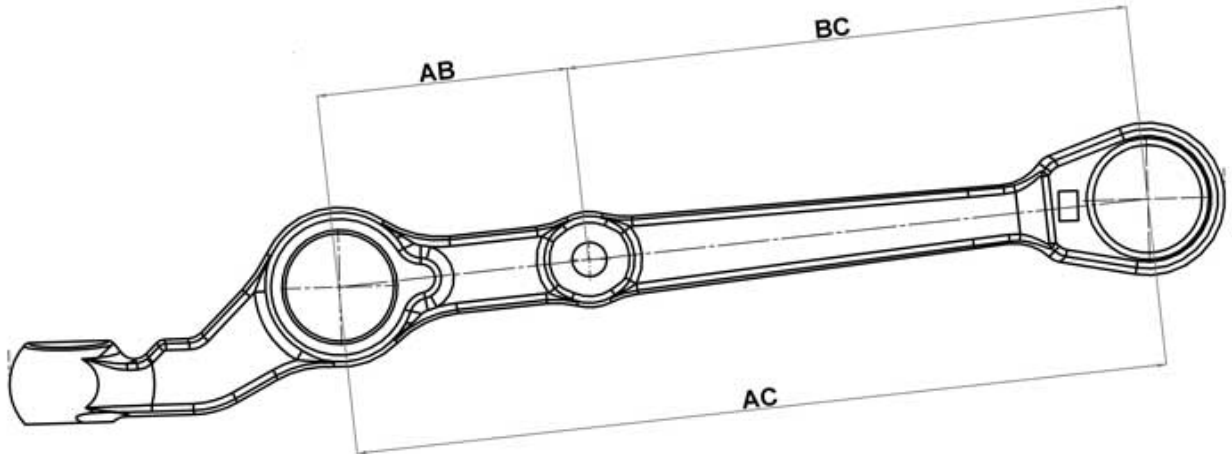

The distances between the axes A, B and C in XY-plane are calculated.

- Detail twisting calculation

The maximum angle between the lines running along the upper landing of three elbows perpendicular to the detail axis is calculated, degrees. That is, the difference between the angles of these three lines is calculated pairwise. Detail twisting is the maximum difference of the angles.

10.1.3. Input tolerances and setting calculation parameters

To enter the setup mode press the **Parameter Setting** button in the main window of the application. The settings window contains several tabs.

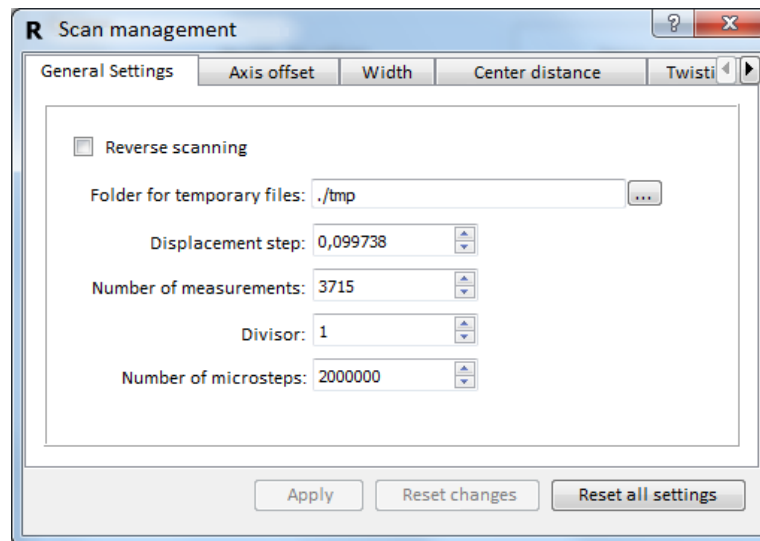

Tab **General Settings**.

- turn on the reverse scanning when scanner movement direction need to be reversed
- folder for temporary files – set the pass to store temporary files if necessary
- displacement step, number of measurements, divisor, number of microsteps – factory defaults are shown

The other tabs are designed for the input of tolerances. The logic of the signaling LEDs and the logic output of the synchronization unit will comply with the established tolerances.

Tabs **Axis offset** and **Width**

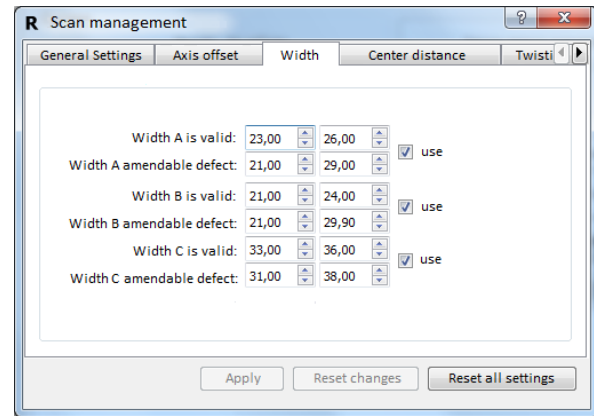
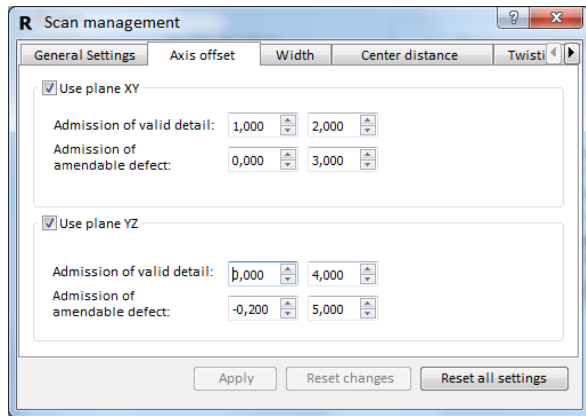

Tabs **Center distance** and **Twisting**

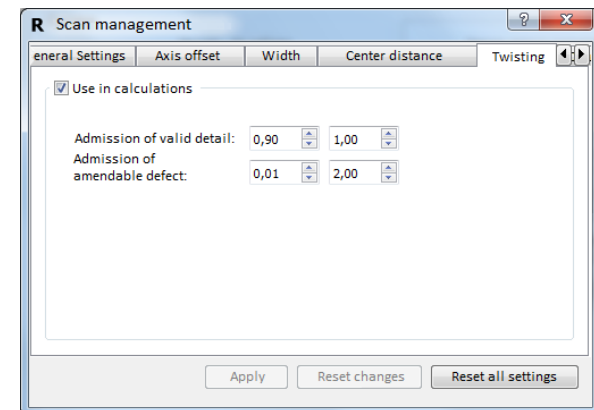
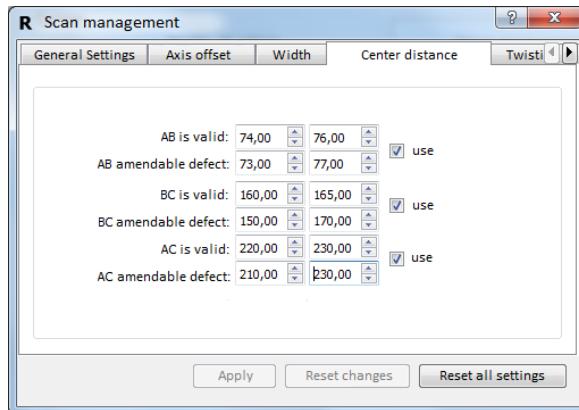

10.1.4. Logging events and results

During operation of the machine the scanning control application conducts event logging to the files **system[index]** in the **/Log/** folder. The file title contains an index, when exceeding the current file size a new log file with the index for 1 bigger than the previous is created.

The results of processing the model of the detail as well as the accidents are logged to the database. The database is implemented on the basis of **sqlite**. Database files are stored in **[month].sqlite** files, where **month** is the number of the current month. That means all entries in a month are stored in a single file. All database files are stored in the folders form **/[year]/**, where **year** is the number of current year. All the data belonging to the particular year measurements are in the same appropriately named folder. According to these data the statistics viewer builds statistical reports. All data can be transferred for analysis to another computer preserving the folder structure.

When the application is working the initial scanning data three-dimensional models in the ***bin** format are recorded in the temporary directory **/tmp/**. The address of the temporary folder is specified in the program settings. The files formed in this folder can be used for detailed analysis of the calculation faults, development of the new and correction of the existing calculations.

10.1.5. Calibrating the machine.

To calibrate the machine install the calibration block (supplied rectangular specified sizes block) in the control position, see the Figure below.

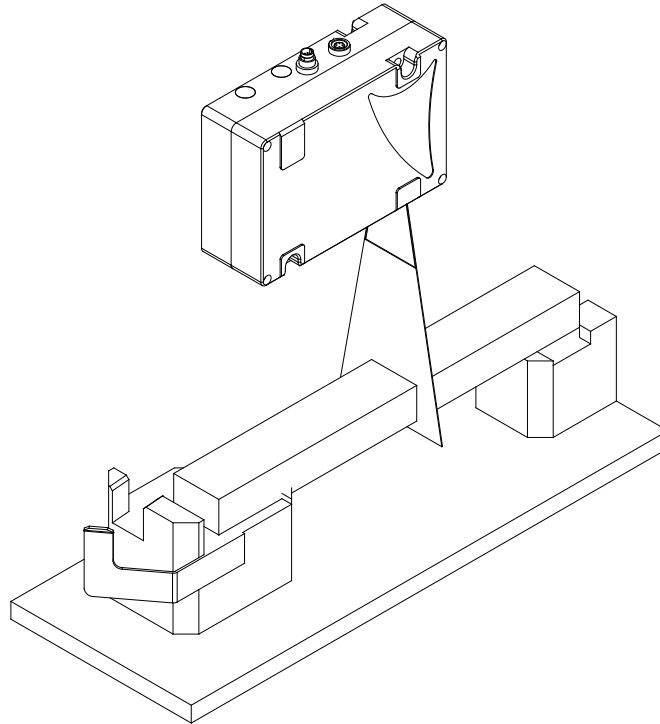

In the main window of the application click **Calibrate**. After the block is scanned the machine is ready for operation.

10.2. Detail statistics viewer

To view the statistics of measurements run **RFStatViewer.exe**. The main window of the application is shown in the Figure below.

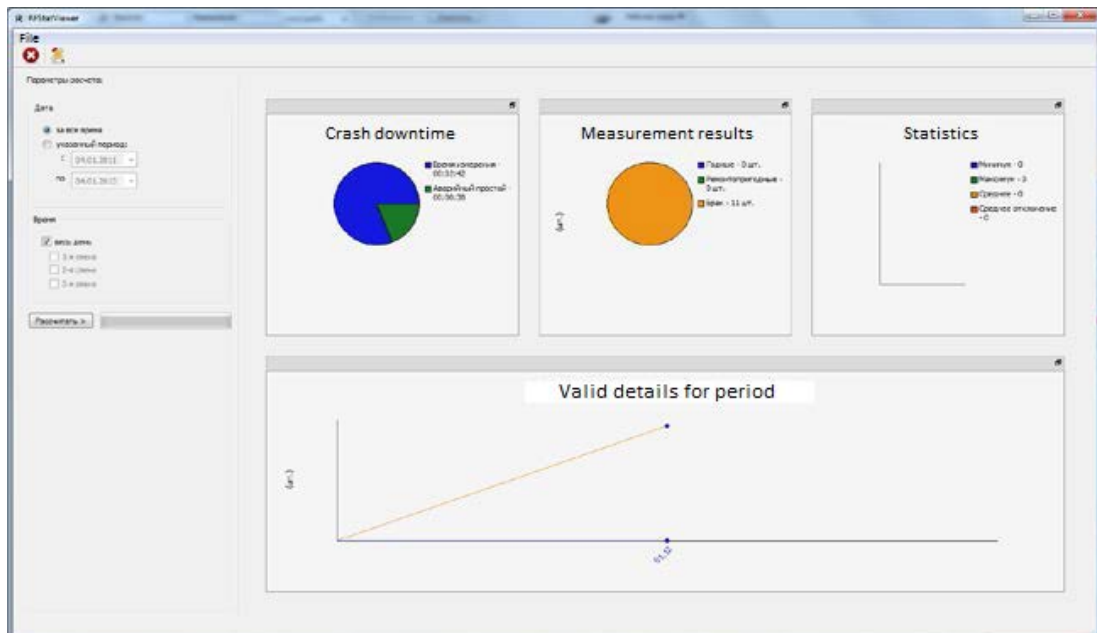

The application allows to generate statistical reports for a given period of time.

10.3. Signal block testing application

To test the signal block run **TestSignalBlock.exe**. The main window of the application is shown in the Figure below.

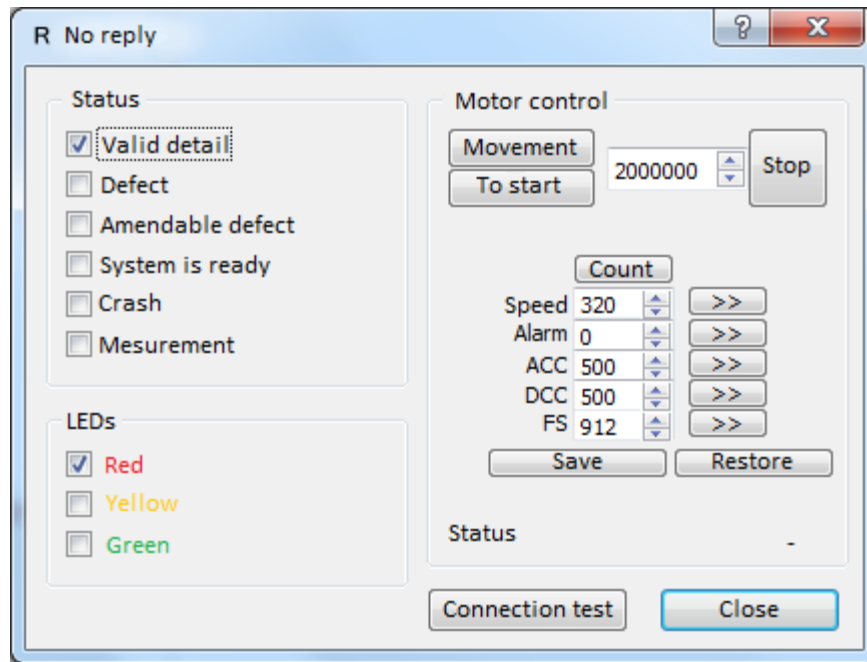

Condition Group enables to test the logic outputs, **LEDs** Group tests LED performance. To test the movement system set the number of steps and click **Move**. To return the carriage in the initial position click **Ini Position**. The other parameters are shown informative.

11. Intended use

11.1. Preparation for use

Preparation the machine includes:

- external inspection;
- set up on a conveyer;
- switching the machine;
- calibrating the machine;
- checking the machine.

11.1.1. External inspection

Before operating it is needed to ensure of the serviceability of the equipment, check the cables, ground wires. Check the condition of output windows of the scanner and, if necessary, wipe them with a soft cloth.

11.1.2. Set up on a conveyer

Install the machine on a conveyer according to the Paragraph 8 of this manual. Make the electrical connections in accordance with the Paragraph 9.

11.1.3. Switching the machine

11.1.4. Calibrating the machine

Calibrate the machine according to the Paragraph 10.1.5. Setting calibration should be held on a daily basis before the work shifts.

11.1.5. Checking the machine

To check the functionality of the machine conduct a full cycle control of the geometrical parameters of the control sample detail. It is recommended to conduct at list one functional test of the machine at the beginning or during the shift.

11.2. Operating the machine

The geometric parameters measurement cycle is fully automated and operation of the machine is reduced to the work with the program.

- run the machine control application
- add/control the tolerances according to the Paragraph 10.1.3
- when getting the synchronization signal the machine performs the scanning of the detail, calculation of the geometrical parameters and grading
- after the scanning the carriage automatically returns to the starting position and the machine waits for the next synchronization signal

12. Maintenance

12.1. General instructions

Maintenance of the machine is carried out to ensure constant-ready status and continued availability of its work and to prevent premature failure. Maintenance includes preventive measures aimed at identification and elimination of defects and to ensure the normal operation while installation and working. It is recommended to conduct the daily, weekly and annual maintenance work.

12.2. Safety precautions

During the installation maintenance security measures outlined in the Paragraph 1 should be observed.

12.3. Maintenance procedure

12.3.1. Daily maintenance work

Daily maintenance includes:

- visual inspection of the machine,
- checking of completeness,
- inspection of the units and elements that make up the machine,
- checking for any damage of the structural elements, power and instrument cables, indicators and connectors,
- weakening of screw connections and insulation failures,
- before starting work, it is necessary to wipe the input and output laser scanner windows with a soft dry cloth.

12.3.2. Weekly maintenance work

Weekly maintenance includes:

- cleaning of laser scanner windows with a dry soft lint-free cloth from contamination of dirt;
- checking of free movement of the carriage.

12.3.3. Yearly maintenance work

Authenticated calibration of the laser scanner should be made once a year

12.4. Operability test

It is recommended to conduct the functional test at least once at the beginning or during the shift, for what it is necessary to complete full cycle control of the geometrical parameters of the control sample (not supplied).

13. Routine repairs

Possible troubles and trouble-shooting instructions are given in the following table.

Troubles	Possible cause	Corrective actions
Incorrect measurements	The influence of an external illumination source	Remove the external source or protect the controlled item from its influence.
	Wet surface of the detail with the drops of coolant and water	Remove the drops of coolant and water
	Laser scanner window pollution	Clean the scanner window
	Malfunctions of the software	Reboot the computer
	The detail is unsuitable for the control	Remove any external objects or coatings from the surface of the detail
	Scanner displacement	Calibrate the machine
Other		Contact the manufacturer

14. Warranty policy

Warranty assurance for the 3D Laser measurement machine RF1010SL – 24 months from the date of putting in operation; warranty shelf-life - 12 months.

15. Distributors

<p>AUSTRALIA</p> <p>XN Innovation LG Centre, Suite 1, Level M, 55 Paramatta Rd, NSW, 2141, Lidcombe, Australia Tel: +61 (0)2 8091 2426 Fax: +61 (0)2 9648 6597 xni.sales@gmail.com</p>	<p>BENELUX</p> <p>Altheris B.V. Scheveningseweg 15 2517 KS The Hague, The Netherlands Tel: +31 (70) 3924421 Fax: +31 (70) 3644249 sales@altheris.nl www.altheris.com</p>	<p>BULGARIA, HUNGARY</p> <p>RMT Ltd. R Zahradni 224 739 21 Paskov, Czech Republic Tel: +420 558640211 Fax: +420 558640218 rmt@rmt.cz lubomir.kolar@rmt.cz www.rmt.cz</p>
<p>CHINA</p> <p>Zhenshangyou Technologies Co.,Ltd. Rm 1806, Block B, Jinhaian Building Chuangye Road, Nanshan District Shenzhen, 518054, China Tel: 86)755-26528100/8011/8012 Fax: (86)755-26528210/26435640 info@51sensors.com www.51sensors.com</p>	<p>CZECH REPUBLIC</p> <p>ASCO RAIL sp. z o.o. RAILWAY INSTRUMENTS ONLY ul. Wielowiejska 53 44-120 PYSKOWICE, Poland Tel: + 48 32 230 45 70 Fax: + 48 32 332 70 34 biuro@ascorail.pl www.ascorail.pl</p>	<p>GERMANY</p> <p>Disynet GmbH Westwall 12 D-41379 Brueggen, Germany Tel: +49 (2157) 8799-0 Fax: +49 (2157) 8799-22 disynet@sensoren.de www.sensoren.de</p>
<p>GERMANY</p> <p>BIP-Industrietechnik GmbH RAILWAY INSTRUMENTS ONLY Am Elisabethhof 22, D-14772 Brandenburg D-41379 Brueggen, Germany Tel: +49 (0) 33 81 75 90 0 Fax: +49 (0) 33 81 75 90 11 info@bip-industrie.de www.bip-industrietechnik.de</p>	<p>INDIA</p> <p>Pragathi Solutions #698, 5th Main, 8th Cross, HAL 3rd Stage, New Tippasandra Road, Bangalore, 560075, India Tel: +91 80 32973388 Tel/fax: +91 80 25293985 Mobile: +91 9448030426/ +919448492380 sales@pragathisolutions.in www.pragathisolutions.in</p>	<p>INDONESIA</p> <p>PT. DHAYA BASWARA SANIYASA Sentra Niaga Puri Indah Blok T6 No. 41 Kembangan, Jakarta, 11610, Indonesia Tel: 021 5830 4517 Fax: 021 5830 4518 management@ptdbs.co.id</p>

<p>ITALY</p> <p>FAE s.r.l. Via Tertulliano, 41 20137 Milano, Italy Tel: +39-02-55187133 Fax: +39-02-55187399 fae@fae.it www.fae.it</p>	<p>FINLAND</p> <p>TERÄSPYÖRÄ-STEELWHEEL OY RAILWAY INSTRUMENTS ONLY Juvan teollisuuskatu 28 FI-02920 ESPOO, Finland Tel: +358 400 422 900 Fax: +358 9 2511 5510 steelwheel@steelwheel.fi www.teraspyora.fi</p>	<p>LITHUANIA</p> <p>JSC "Comexim" Serbentu, 222, LT-5419 Siauliai, Lithuania Tel/Fax:+370 41553487 comexim@siauliai.aiva.lt www.komeksimas.lt</p>
<p>MALAYSIA</p> <p>OptoCom Equiptech (M) Sdn Bhd H-49-2, Jalan 5, Cosmoplex Industrial Park, Bandar Baru Salak Tinggi, Sepang, Malaysia Tel: 603 8706 6806 Fax: 603 8706 6809 optocom@tm.net.my www.optocom.com.my</p>	<p>POLAND</p> <p>RIFTEK EUROPE sp. z o.o. ul. Domaniewska 17/19, 02-672 Warsaw, Poland info@riftek.com www.riftek.com</p>	<p>POLAND</p> <p>MTL ASCO Sp. z o.o. RAILWAY INSTRUMENTS ONLY ul. Wielowiejska 53 44-120 PYSKOWICE (k/ GLIWIC), Poland Tel:+ 48 32 230 45 70 Fax: + 48 32 332 70 34 serwis@mtlasco.pl www.ascorail.pl</p>
<p>PORTUGAL</p> <p>UltraSens Qt. da Portela, Lt. 22.1, Ap. 152 3030 - 502 Coimbra, Portugal Phone +351 239 796 277 Fax: +351 239 918 267 info@ultrasens.com www.ultrasens.com</p>	<p>SERBIA, SLOVAKIA</p> <p>ASCO RAIL sp. z o.o. RAILWAY INSTRUMENTS ONLY ul. Wielowiejska 53 44-120 PYSKOWICE, Poland Tel:+ 48 32 230 45 70 Fax: + 48 32 332 70 34 biuro@ascorail.pl www.ascorail.pl</p>	<p>SOUTH KOREA</p> <p>PROSEN. CO., LTD 211/ Jung-woo Venture 2, 1228-1 Singil-dong, Danwon-gu, Ansan-si, Gyeonggi-do, 425-839, Republic of Korea Tel: +82-(0)31-508-3456~7 Fax: +82-(0)31-624-3458 prosen-sor@naver.com www.prosen.kr</p>
<p>SOUTH KOREA</p> <p>DAESHIN T&S CO., LTD 1702 Ace High-End Tower 5, Gasan-dong, Geumcheon-Gu, Seoul, Korea Tel: +82-2-2279-8800 Fax: +82-2-2277-6667 railstar1983@korea.com www.railstar.co.kr</p>	<p>SPAIN</p> <p>Iberfluid Instruments S.A. Cardenal Reig, 12 08028 Barcelona, Spain Tel: +34 93 447 10 65 Fax: +34 93 334 05 24 myct@iberfluid.com www.iberfluid.com</p>	<p>SWEDEN, NORWAY, DENMARK</p> <p>BLConsult Rävbergsvägen 31 SE 713 30, Nora, Sweden Tel: +46 (0) 587 153 20 Mobile: +46 (0) 70 663 19 25 info@blconsult.se www.blconsult.se</p>
<p>SWITZERLAND</p> <p>ID&T GmbH Gewerbstrasse 12/a 8132 Egg (Zurich), Switzerland Tel: +41 (0)44 994 92 32 Fax: +41 (0)44 994 92 34 info@idtlaser.com www.idtlaser.com</p>	<p>TURKEY</p> <p>MATES A.S. RAILWAY INSTRUMENTS ONLY Gezegen Sok. N: 10 GOP ANKARA, TURKEY Tel: +90 312 447 2192 Fax: +90 312 447 2193 mates@mates.com.tr www.mates.com.tr</p>	<p>UKRAINE</p> <p>KODA Frunze st 22, 61002, Harkov, Ukraine Tel/fax: +38 057 714 26 54 mail@koda.com.ua www.koda.com.ua</p>

<p>UNITED KINGDOM, IRELAND</p> <p>Ixthus Instrumentation Ltd The Stables, Williams' Barns Tiffield road, Towcester, Northants Tel: 01327 353437 Fax: 01327 353564 www.ixthus.co.uk info@ixthus.co.uk</p>	<p>USA, CANADA, MEXICO</p> <p>International Electronic Ma- chines Corporation RAILWAY INSTRUMENTS ONLY R 60 Fourth Avenue, Albany, New York, USA Tel: +1 (518) 449-5504 Fax: +1 (518) 449-5567 rail- way_marketing@iem.net www.iem.net</p>	<p>USA, CANADA, MEXICO</p> <p>Acuity Products of Schmitt Industries, Inc. 2765 NW Nicolai Street Portland, OR, 97210, USA Tel: +1-503-227-7908 sales@acuitylaser.com</p>
--	--	--