



RIFTEK
Sensors & Instruments



LASER WHEEL PROFILOMETER

IKP-5 Series, Model 2024 Year

User's manual

www.riftek.com
info@riftek.com

Contents

1.	Safety precautions and measurement conditions.....	6
2.	CE compliance.....	6
3.	Laser safety.....	6
4.	General information.....	6
5.	Operation principle.....	7
6.	Basic technical data.....	7
7.	Complete set to be supplied.....	8
7.1.	Android App licensing.....	9
8.	Device structure.....	9
8.1.	Basic components of the device and their functions.....	9
8.1.1.	PDA.....	9
8.1.2.	Laser scanning module.....	10
8.1.2.1.	Laser module options.....	10
8.1.3.	Calibration block.....	13
9.	Example of designation when ordering.....	14
10.	Geometric parameters of the wheel under control.....	14
10.1.	Flange height, sH.....	14
10.2.	Flange thickness, sD.....	15
10.3.	Flange slope, qR.....	15
10.4.	Wear parameters.....	16
10.5.	Angle parameters.....	17
10.6.	Rim parameters.....	17
10.7.	Wheel diameter.....	18
10.8.	Tram wheel parameters.....	18
10.9.	Wheel defects.....	18
11.	Coordinate system.....	19
12.	Adding and selecting the measurement device.....	19
13.	PDA program setting.....	24
13.1.	Setting general parameters.....	24
13.1.1.	Setting a password.....	25
13.1.2.	Bluetooth settings.....	26
13.1.3.	Change the program language.....	27
13.2.	Setting general measurement parameters.....	27
13.2.1.	Setting the measurement type.....	28
13.3.	Setting up data export.....	29
13.3.1.	Export to PDA.....	29
13.3.2.	Export to PC data base.....	30
13.3.2.1.	PC server settings.....	31
13.3.2.2.	PDA server settings.....	34
13.3.3.	Sending data by email.....	35
13.4.	Setting IKP measurement parameters.....	36
13.4.1.	Calculation methods.....	37
13.4.2.	Calculated parameters.....	37
13.4.3.	L parameters.....	38
13.4.4.	Preset values.....	39
14.	Setting reference profiles, measurement schemes, tolerances.....	40
14.1.	Reference profile.....	40
14.1.1.	Selecting and deleting the reference profile.....	41
14.1.2.	Uploading the reference profile to the database.....	43
14.2.	Measurement scheme.....	43
14.2.1.	Selecting and deleting the measurement scheme.....	44
14.2.2.	Uploading a new measurement scheme.....	45

14.3.	Tolerance.....	47
14.3.1.	Viewing and deleting tolerances.....	47
14.3.2.	Adding tolerances.....	48
14.4.	Wheelset type.....	51
14.4.1.	Selecting and deleting the wheelset type.....	51
14.4.2.	Adding the wheelset type.....	52
14.4.3.	Editing the wheelset type.....	52
15.	Software update.....	53
16.	Measurement.....	55
16.1.	Quick setup.....	55
16.2.	IKP-5.....	57
16.2.1.	Turning on the gauge.....	57
16.2.2.	Installing the gauge on the wheel.....	58
16.2.3.	Rapid measurement.....	59
16.2.4.	Measurement by scheme.....	62
16.3.	IDK-BT.....	66
16.3.1.	Turning on the gauge.....	66
16.3.2.	Installing the gauge on the wheel.....	66
16.3.3.	Rapid measurement.....	67
16.3.4.	Measurement by scheme.....	68
16.4.	IMR.....	72
16.4.1.	Turning on the gauge.....	72
16.4.2.	Installing the gauge on the wheel.....	72
16.4.3.	Rapid measurement.....	73
16.4.4.	Measurement by scheme.....	74
17.	IKP calibration.....	78
17.1.	Preparing for calibration.....	78
17.2.	Calibration procedure.....	78
18.	Browsing the database.....	81
18.1.	Exporting data.....	81
18.2.	Filtering data.....	83
18.3.	Deleting data.....	86
18.4.	Viewing measurement results.....	87
18.4.1.	Saving the wheel profile as the reference.....	88
18.4.2.	Viewing wheel parameters.....	89
18.4.3.	Viewing the wheel profile.....	90
19.	Data exchange between PDA and a PC.....	90
19.1.	Synchronization of PDA and a PC.....	90
19.2.	Data transfer.....	92
19.2.1.	Transferring the database file to a PC.....	92
19.2.2.	Transferring the reference file.....	92
19.2.3.	Transferring the scheme file.....	93
20.	Installation of software on PC and startup.....	93
20.1.	Installation of database support software.....	93
20.2.	Synchronization of PDA and PC.....	93
20.3.	Program startup.....	94
21.	User settings of the program.....	95
21.1.	Parameters setting.....	95
21.1.1.	"Wheelset's parameters" tab.....	95
21.1.2.	"Calculated parameters" tab.....	96
21.1.3.	"L-parameters" tab.....	96
21.1.4.	"Measurement method" tab.....	96
21.1.4.1.	Selection of measurement units.....	97
21.2.	Database settings.....	97
21.2.1.	Setting the path to database.....	97
21.2.2.	Creation of empty database.....	98
21.2.3.	Import of database.....	98

21.2.4.	Selection of software language.....	98
21.2.4.1.	Preparation and installation of the language support file.....	99
21.3.	Registration data.....	99
21.3.1.	Selection of the organization.....	99
21.3.2.	Registration of operators.....	100
21.3.3.	Registration of series.....	100
21.3.4.	Registration of car/locomotive numbers.....	101
21.3.5.	Registration of tolerances.....	101
21.3.6.	Registration of reference profiles.....	101
21.3.6.1.	Request and registration of the profile file.....	102
22.	Data exchange between PDA and PC.....	103
22.1.	ActiveSync synchronization.....	103
22.1.1.	Transfer of database file to PC.....	103
22.1.2.	Transfer of language file from PC to PDA.....	104
22.1.3.	Transfer of language file from PDA to PC.....	105
22.1.4.	Transfer of reference profile files from PC to PDA.....	105
22.1.5.	Transfer of processing scheme file from PC to PDA.....	106
22.1.6.	Updating of PDA software.....	106
22.2.	Mass Storage synchronization.....	107
23.	Working with profilograms and wear calculations.....	108
23.1.	Browsing the graph and profile coordinates.....	108
23.2.	"Parameters" tab.....	109
23.2.1.	Selecting a profile to compare.....	109
23.2.2.	Selecting L-parameters values.....	109
23.2.3.	Geometric parameters of the profile.....	110
23.3.	Wear calculation.....	110
23.3.1.	Fast wear calculation.....	110
23.3.2.	Wear calculation at all points.....	110
23.3.3.	Export to Excel, DXF, REF.....	111
23.4.	Alignment of profiles.....	111
23.5.	Superposition of profiles.....	112
23.6.	Rescaling.....	113
24.	Implementation of minimum wheel truing function.....	113
25.	Scanning and editing of data.....	114
25.1.	Scanning and filtering of data.....	114
25.2.	Editing data.....	116
25.3.	Report preparation.....	117
25.3.1.	Excel-format report.....	118
25.3.2.	Report for printout.....	118
26.	Taking measurements under PC control (without PDA).....	119
26.1.	Calibration.....	120
26.1.1.	Bluetooth connection.....	120
26.1.2.	Calibration of the profilometer.....	121
26.2.	Measurement by using PC.....	122
26.2.1.	Saving of data.....	122
27.	Annex 1. Charging procedure.....	123
28.	Annex 2. Program for creating the measurement schemes.....	123
29.	Annex 3. Testing and calibration.....	125
29.1.	Preparation for testing/calibration.....	125
29.2.	Testing.....	127
29.3.	Calibration.....	128
29.4.	Restoring the factory settings.....	129
30.	Annex 4. Software application for working with the "A.U.R.A. Wheel" system.....	130
30.1.	Installation.....	130
30.2.	Settings.....	130
30.2.1.	Language.....	131
30.2.2.	Gauge type selection.....	131

30.2.3.	Password.....	134
30.2.4.	Calculation methods.....	135
30.2.5.	Selection of displayed parameters.....	135
30.2.6.	L-parameters.....	136
30.2.6.1.	Preset values.....	136
30.2.7.	Reference profile selection and installation.....	137
30.2.7.1.	Writing the reference profile to the database.....	137
30.2.8.	Measurement scheme.....	137
30.2.8.1.	Selection or removal of the measurement scheme.....	138
30.2.8.2.	Formation of a new measurement scheme.....	138
30.2.9.	Tolerances.....	139
30.2.10.	Vehicles.....	140
30.3.	Measurements.....	140
30.3.1.	Single measurement.....	141
30.3.2.	Simple measurement.....	142
30.3.2.1.	Measurement.....	144
30.3.2.2.	Measuring by IDK, IMR.....	147
30.3.3.	Automated measurement.....	148
31.	Warranty policy.....	150
32.	List of changes.....	150
33.	Distributors.....	150
34.	RIFTEK's measurement instruments for railway transport.....	154

1. Safety precautions and measurement conditions

- Prior to mounting the profilometer onto the wheel, areas of contact of the side supports with the wheel surface should be thoroughly cleaned from dirt.
- When mounting the module on the wheel, do not allow heavy shocks of its support against the wheel.
- The output window of the profilometer and profilometer supports must be carefully inspected and cleaned.
- Do not use laser module in locations close to powerful light sources.

2. CE compliance

The profilometers have been developed for use in industry and meet the requirements of the following Directives:

- EU directive 2014/30/EU. Electromagnetic compatibility (EMC).
- EU directive 2011/65/EU, “RoHS” category 9.

3. Laser safety

The profilometer makes use of an c.w. 660 (or 405) nm wavelength semiconductor laser. The maximum output power is 1 mW. The device belongs to the 2 laser safety class according IEC/EN 60825-1:2014. The following warning label is placed on the profilometer body:

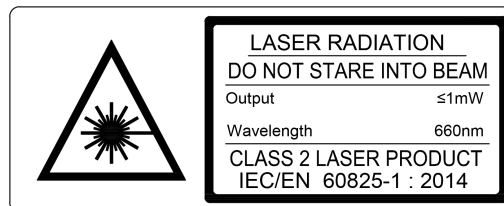

The following safety measures should be taken while operating the profilometer:

- Do not target the laser beam to humans.
- Do not disassemble the sensor.
- Avoid staring into the laser beam.

4. General information

The Laser Profilometer IKP-5 Series is employed for measurement

- wheel flange thickness,
- flange slope
- flange height
- wheel wear parameters,
- rim/tire thickness and width.
- Taking full profile of the wheel rolling surface.
- Maintaining the wheel wear database (computer software is available on the website for free download)
- Tolerance control and sorting when checking, inspecting, repairing and forming railway wheelsets.

Measurements are made directly on the rolling stock without rolling out the wheelset.

5. Operation principle

Operator mounts the laser scanning module onto the wheel to be measured. Having received a command from PDA or PC, the laser module performs non-contact scanning of the wheel surface. Measurement results (geometric parameters and profile of the surface) are displayed on PDA, can be saved in the PDA memory, and transferred to the PC database. Simultaneously, additional parameters can be saved: operator number, side identifier (left or right wheel), axis number, locomotive (carriage) number, wheel set number, etc.

Hereinafter, PDA refers to an Android device (smartphone or tablet).

Video demonstration: <https://riftek.com/eng/products/~show/instruments/railway-devices/railway-wheel-profile-gauge-ikp>

7

6. Basic technical data

Name of parameter	Value
<i>Measurement range</i>	
Flange height, mm	20...45
Flange thickness, mm	20...50
Flange slope, mm	1...15
Rim thickness, mm	36...100 (30...90)
Diameter (calculation method), mm	400...1400
<i>Measurement error</i>	
Flange height, mm	± 0,1
Flange thickness, mm	± 0,1
Flange slope, mm	± 0,2
Rim thickness, mm	± 0,1
Diameter, mm	± 0,1
Discreteness of indication, all parameters, mm	0.01
Profile measurement range, mm	145
Discreteness of the profile formation, not worse than, mm	0.03 (5800 points for profile)
Dimensions of laser scanning module, mm	see Fig. 5
Measurement time, s	adaptive, depending on surface quality, 4 average
Power supply (laser scanning module)	3.7V Li-ion rechargeable battery 5400mAh for standard IKP and 2400mAh for Short and Super-short
The number of measurements that can be taken before battery recharge is not less than	5000
Laser module battery life time	5 million measurement cycles
Power supply (PDA)	3.7V Li-ion battery 10000mAh
PDA memory capacity	100 000 measurements
PDA dimensions, mm	193x90x25
PDA display size	6.23"
PDA display resolution	1080x2280
Interface between laser scanning module and PDA	Bluetooth
Interface between PDA and PC	Wi-Fi
Working temperature range, °C	-20...+50
Enclosure rating	IP42 or IP64

7. Complete set to be supplied

Designation	Name	Quantity	Weight, kg
RF303S	Digital readout device (PDA)*	1	0.42
RF505	Laser scanning module	1	0.8
RF505.40	Charging device 5V 1.0A for laser module	1	0.2
RF505.41	Charging device 5V 2.0A for PDA	1	0.2
RF505.42	Data cable	1	
RF505.43	Bluetooth adapter	1	
RF505.30	Case	1	1.2
RF505UM	User Manual	1	
Calibration tools (option):			
RF505.11	Calibration block		4
RF505Calibr	Calibration software is available on the website for free download		

*It is possible to supply the instrument without a PDA, in this case, to work with the instrument you will need an Android device (smartphone, tablet) with software (paid license), which can be downloaded from the website:

<https://riftek.com/upload/medialibrary/6a7/guqo45qzqyen9az3ds1no6yw8nj6m772/ikp.zip>

Software for maintaining an electronic database on wheel sets wear is available on the website for free download:

https://riftek.com/upload/iblock/760/ikp5_PC_Software.zip

The profilometer comes in a special case that protects the equipment against any possible damage during transportation.



7.1. Android App licensing

The PDA supports work with three devices, namely IKP-5 (laser profiler of the tread surface of a wheel pair), IDK-BT (the gauge for measuring the diameter of a wheel sets) and IMR (back-to-back distance meter). By default, the PDA is configured to work with the IKP, IDK-BT and IMR devices with which it is supplied.

One software license allows you to connect one set of devices (IKP, IDK-BT and IMR) to the PDA.

One PDA can support an unlimited number of licenses to work with an unlimited number of instrument sets.

One license can be installed on an unlimited number of PDAs.

9

8. Device structure

8.1. Basic components of the device and their functions

Figure 1 shows basic components of the device (chargers are not shown):



Figure 1

Figure 1 indicates: 1 - PDA, 2 - Laser scanning module, 3 - Calibration block.

8.1.1. PDA

PDA is intended for control of the laser scanning module, data reception from the scanning module, indication of measurement results, parameters input and data storage.



Figure 2

Figure 2 indicates:

- 1 - Turn On button
- 2 - Charger connection

8.1.2. Laser scanning module

The module is intended for laser scanning of the wheel surface.

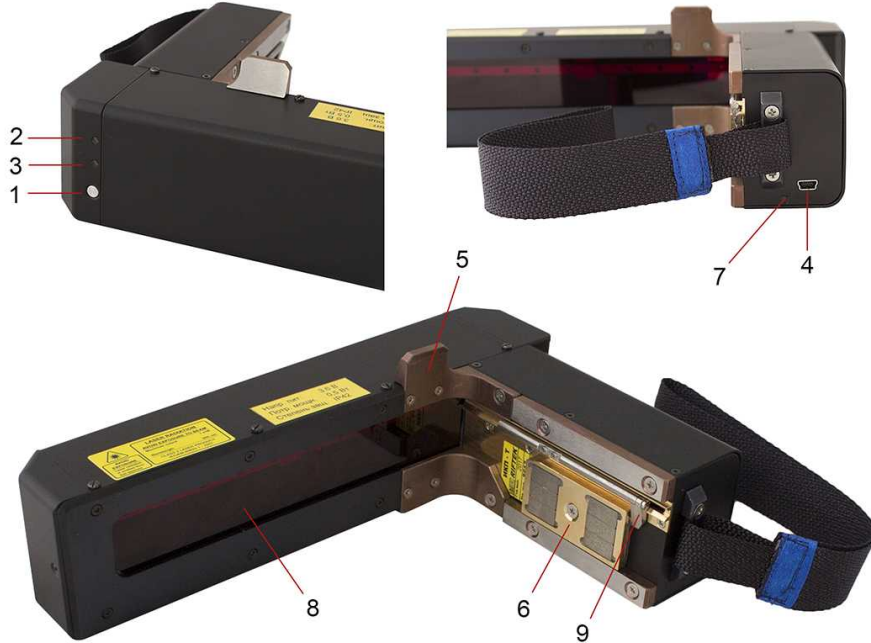

Figure 3

Figure 3 indicates:

- 1 - Turn On button
- 2 - Indicator of turn on (red LED)
- 3 - Indicator of Bluetooth connection (blue LED)
- 4 - Charging device connector
- 5 - Support for mounting of the device on the wheel flange
- 6 - Magnetic support for mounting on the wheel side surface
- 7 - Charging indication, red/green LED
- 8 - Output window
- 9 - Rim measurement rod

8.1.2.1. Laser module options

The figures below show versions of the laser module, differing in the scanning range and the size of the handle for mounting the module on the wheel.

Standard option:

11

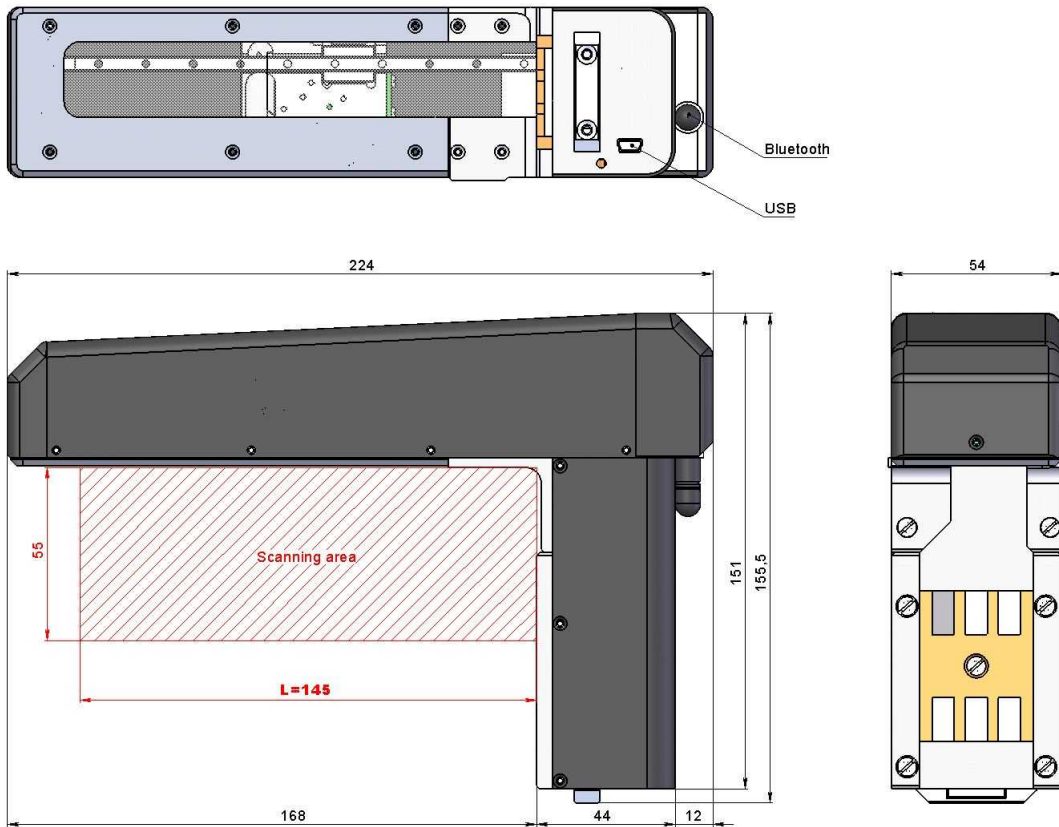

Standard T option (with rim measurement rod):

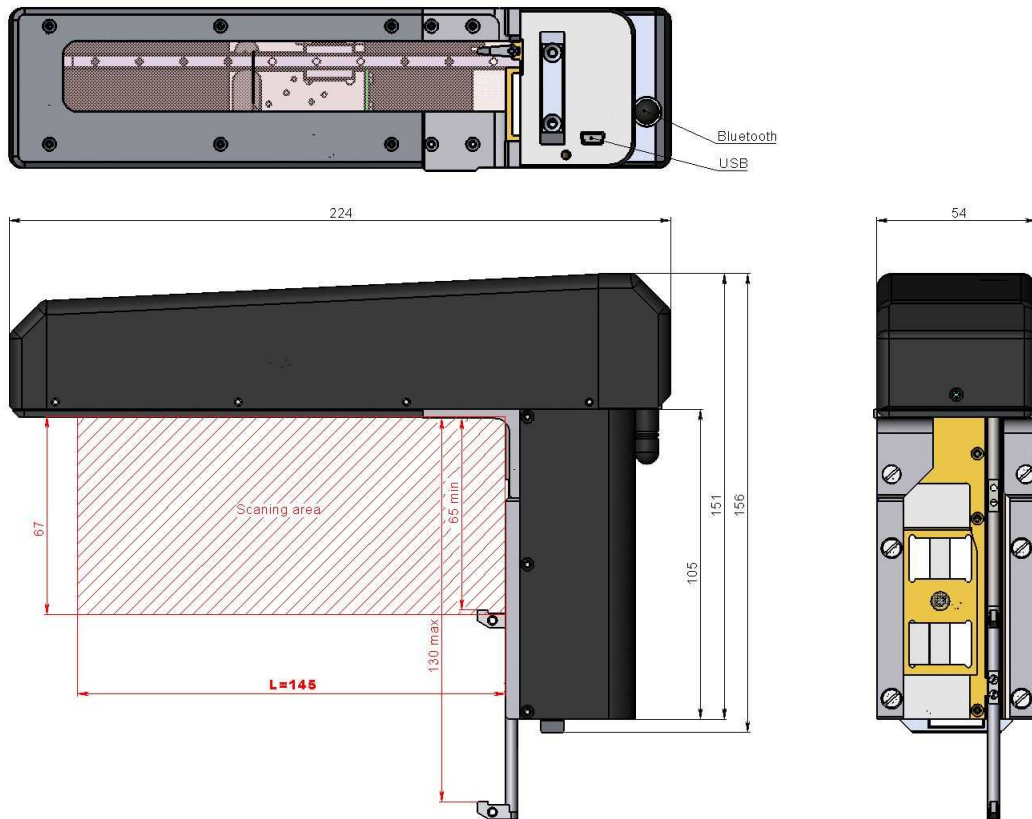

Short option:

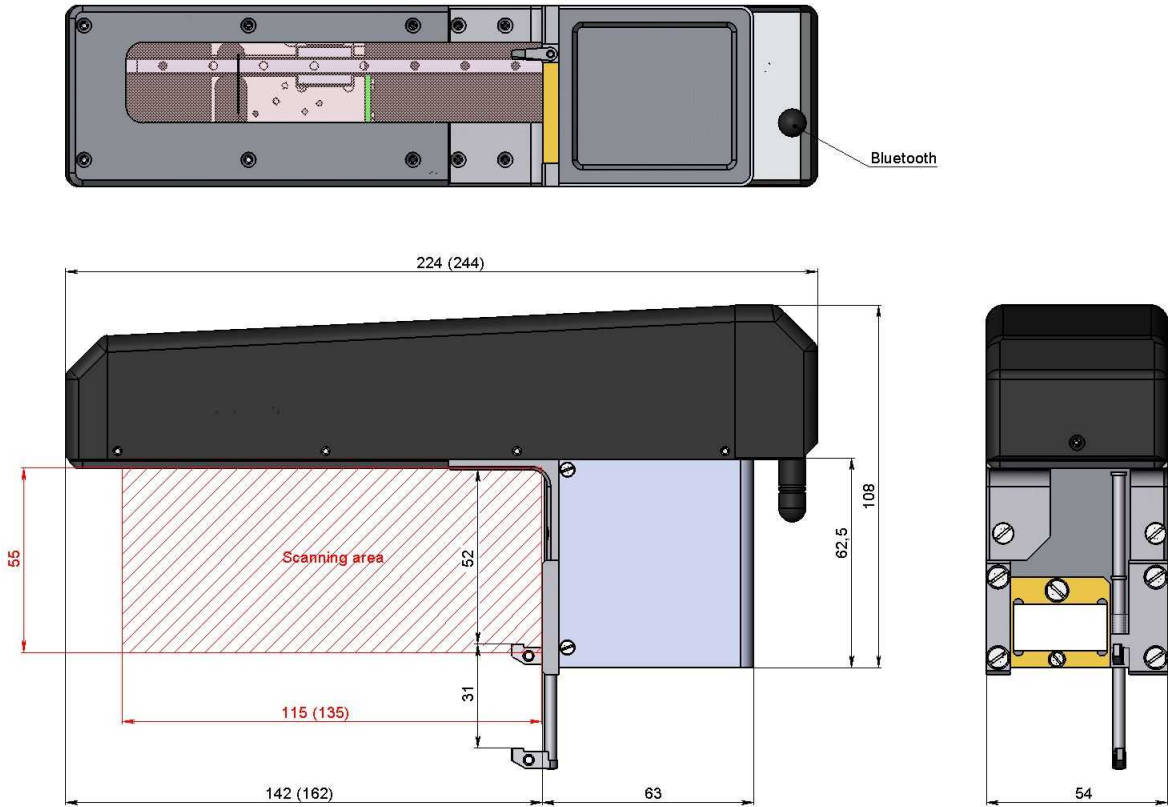

12

SShort option:

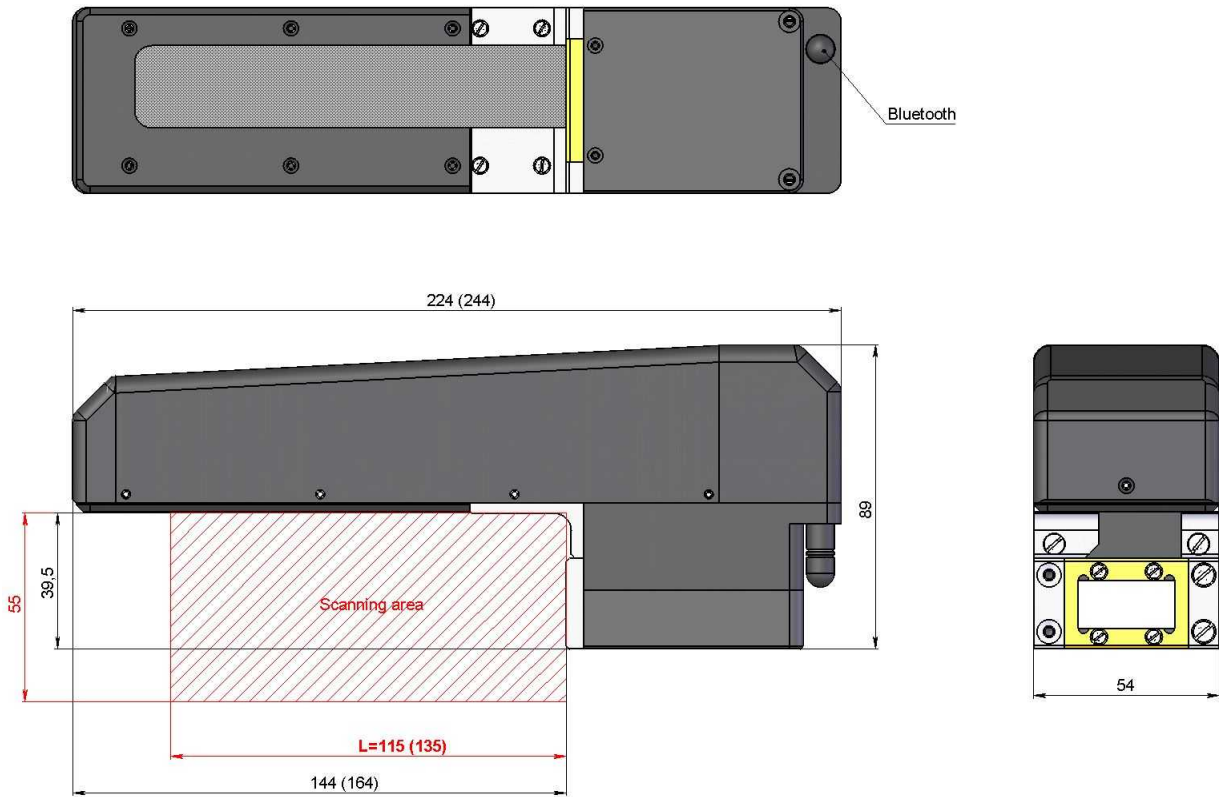

SShort-BT option (with external battery):

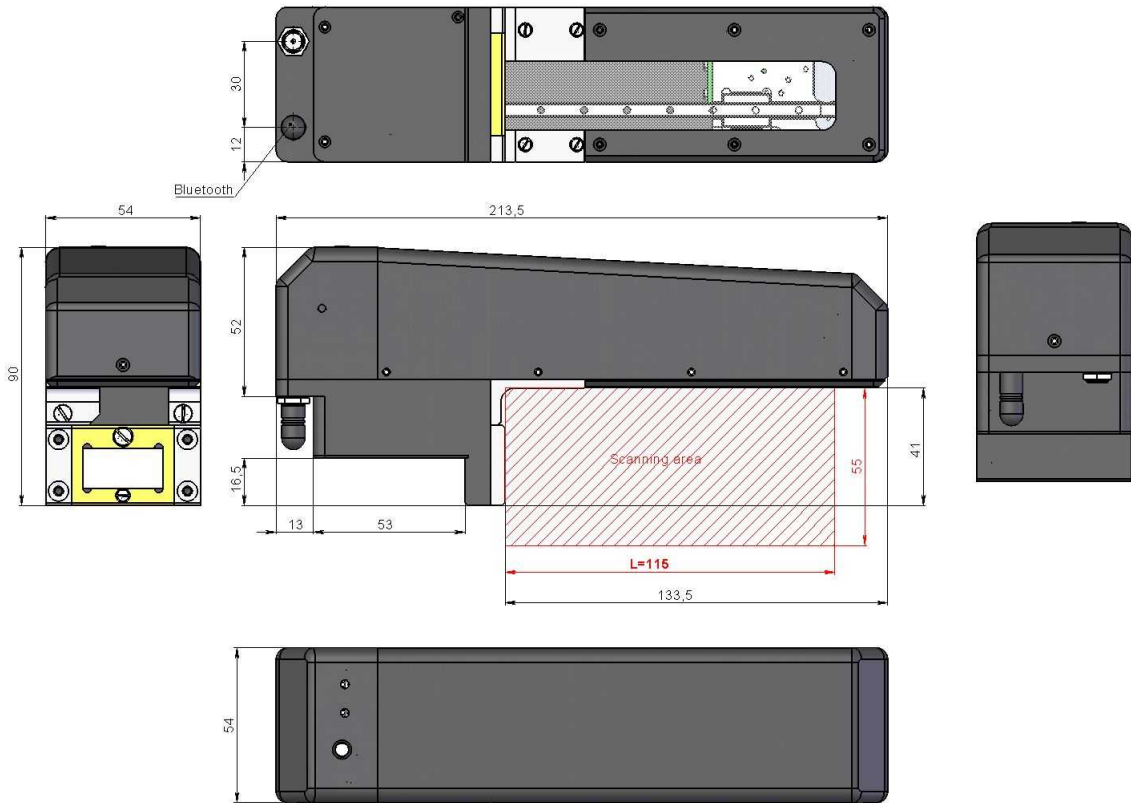

Battery for **SShort-BT** module:

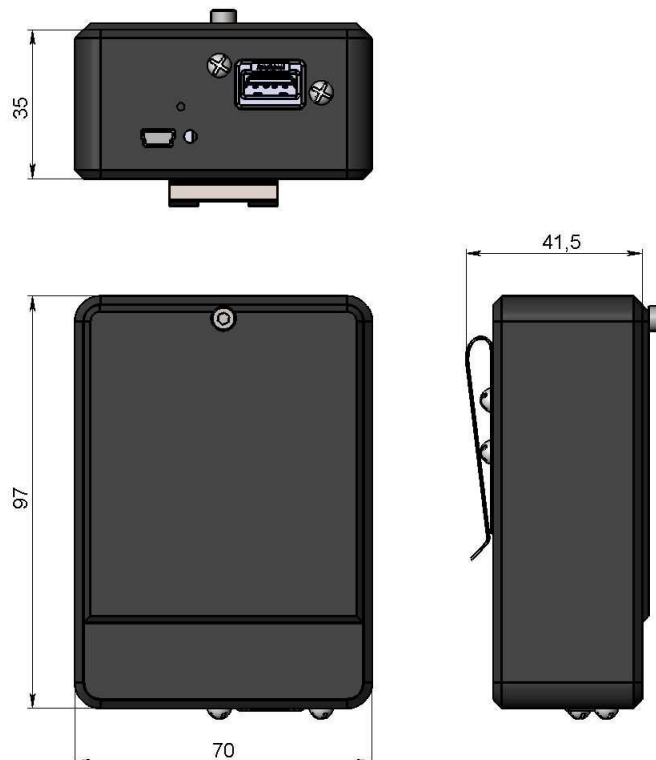

8.1.3. Calibration block

Calibration block is intended for calibration and tests of the profilometer. Calibration block is a metal imitator of the part of wheel with a definite profile.

Overall dimensions of calibration block are shown in Figure 1A in Annex 3. Also possible is supply of a unit with a profile made to the customer's drawings.

9. Example of designation when ordering

IKP-V-M-S-T-R-L-PDA

Symbol	Description
V	Profilometer version: without symbol - Standard version. Short - Short handle. SShort - Super short handle. SShort-EB - Super short handle and external battery.
M	Options of the set of magnets for mounting on the internal/external rim face: S – Standard. Standard magnets (specified by default). F – Forced. Reinforced magnets.
S	Options of the support plates embodiment: D – Direct. Standard plates, profilometer is mounted on the internal rim face (specified by default). I – Invert. Custom plates, profilometer is mounted on the external rim face.
T	Presence of the rim measurement rod.
R	Enclosure rating: without symbol - IP42. 64 - IP64.
L	Measured Rim width (scanning range). Possible ranges are shown on the pictures of scanning module. Customized ranges are possible.
PDA	Presence of PDA.

Example:

IKP-T-PDA – standard laser module, standard magnets; standard support plates; presence of the rim measurement rod, with PDA.

IKP-F-I – standard laser module, reinforced magnets; custom support plates, without PDA.

IKP-Short-T-135 – shorten handle; presence of the rim measurement rod, 135 mm scanning length, without PDA.

10. Geometric parameters of the wheel under control

Geometric parameters of the wheel are calculated automatically after laser scanning of the wheel is completed. To calculate geometric parameters, use is made of reference points on the wheel profile. Location of the reference points is defined by L- and P-parameters. Values of L- and P-parameters preset in PDA are given in paragraph 14.4. and can be changed by the user.

10.1. Flange height, sH

Calculation of the flange height is determined by parameter L2.

The flange height is calculated as a distance measured vertically between the flange top and the point of wheel rolling surface at any preselected distance (L2) away from the inner face of the wheel tire.

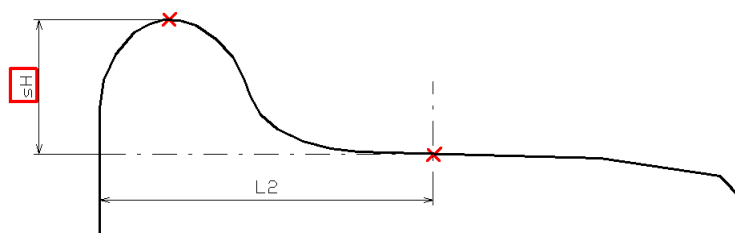

10.2. Flange thickness, sD

Calculation of the flange thickness is determined by parameter L3 that specifies Point 1 on the flange surface. There are two ways to specify the parameter:

Method 1	
Height L3 is measured vertically upward from a point of the wheel rolling surface, the position of which is defined by parameter L2.	
Method 2	
Height L3 is measured vertically downward from the flange top.	

The flange thickness is calculated as a distance measured horizontally at any preselected height (L3) between two points (Point 1 and Point 2) lying on the opposite sides of the flange top.

There are two ways to calculate the flange thickness:

Method 1	
Point 1 is defined by parameter L3. Point 2 is the intersection point of a horizontal line and a line lying on the internal face of the wheel.	
Method 2	
Point 1 is defined by parameter L3. Point 2 is the intersection point of a horizontal line and the flange surface.	

Note: Both calculation methods can be performed simultaneously.

10.3. Flange slope, qR

Calculation of the flange slope is determined by parameters L1 and L3 (or L4).

<p>Height L1 is measured vertically downward from the flange top and determines Point 3 on the flange surface.</p> <p>Height L4 is measured vertically upward from a point of the wheel rolling surface, the position of which is defined by parameter L2 (wheel rolling circle), and determines Point 4 on the flange surface.</p> <p>Height L3 is described in paragraph 10.2.</p>	
--	--

There are three ways to calculate the flange slope:

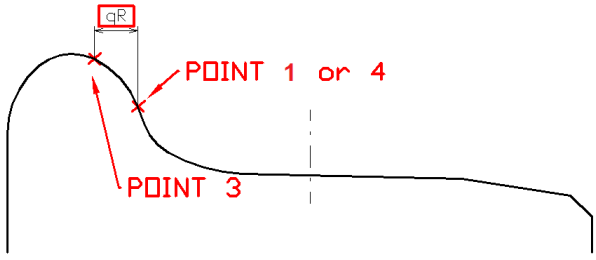
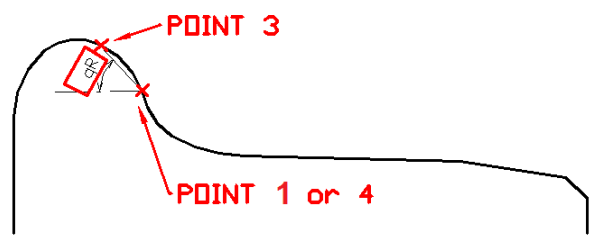
<p>Method 1 Calculation in millimeters</p> <p>The flange slope is calculated as a distance measured horizontally between Point 3 and Point 1 (or 4). The PDA screen displays information in millimeters.</p>	
<p>Method 2 Calculation in degrees</p> <p>The slope is calculated as the inclination angle of a straight line passing through Point 1 or 4. The PDA screen displays information in degrees.</p>	
<p>Method 3 Pass/Fail</p> <p>The calculation is performed according to Method 1. The PDA screen displays information only about whether the measured slope meets the tolerance conditions or not.</p>	

10.4. Wear parameters

The following wear parameters are calculated automatically:

Vertical wear	Wt	is calculated as the difference between the measured flange height and the flange height of the selected reference.
Horizontal wear	Wf	is calculated as the difference between the measured flange thickness and the flange thickness of the selected reference at height L3.
Corner wear	Wr	is calculated as the distance along the normal to the tangent at the point at height L5 from the wheel rolling circle of the measured profile, and the selected reference.

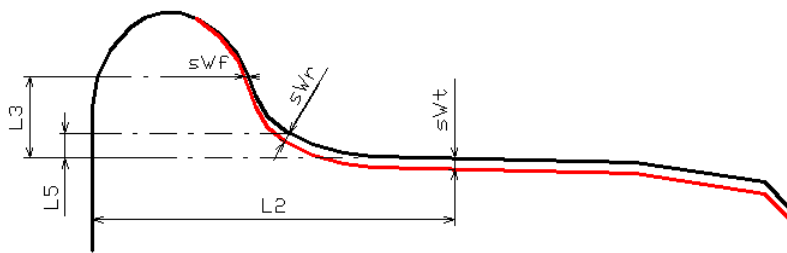

* Red color indicates the worn profile

Hollow	Hl	is calculated as the difference between the maximum and minimum values within the specified limits. The search limits: parameters P7...P8.
--------	----	---

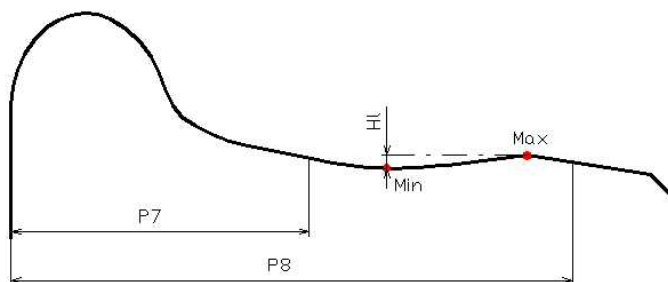

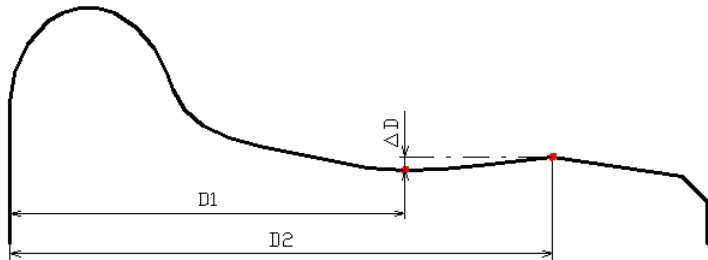
Difference of diameters	dD	is calculated as the difference between diameter at point D1 and diameter at point D2.
		
Even wear	W1	is the maximum vertical wheel wear selected from several measurements.
Uneven wear	W2	is the difference between the maximum wheel wear and the minimum wheel wear (selected from several measurements).

10.5. Angle parameters

The following profile parameters are calculated automatically:

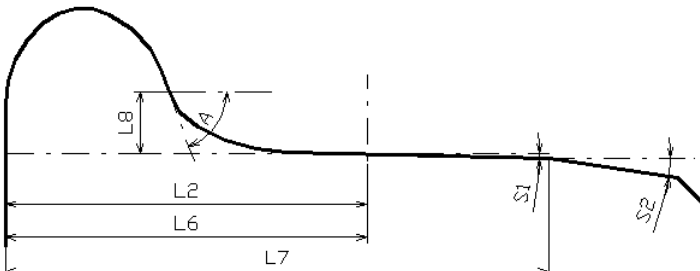
Inclination	A	is calculated as the profile inclination angle (in degrees) at a point with coordinate L8.
Angle 1	S1	is calculated as the inclination angle of the straight line (in percents) passing through points on the wheel surface located at preset distance L6 from the wheel face and the distance L6+10mm from the wheel face.
Angle 2	S2	is calculated as the inclination angle of the straight line (in percents) passing through points on the wheel surface located at preset distance L7 from the wheel face and the distance L7+10mm from the wheel face.
		

10.6. Rim parameters

The following rim parameters are calculated automatically:

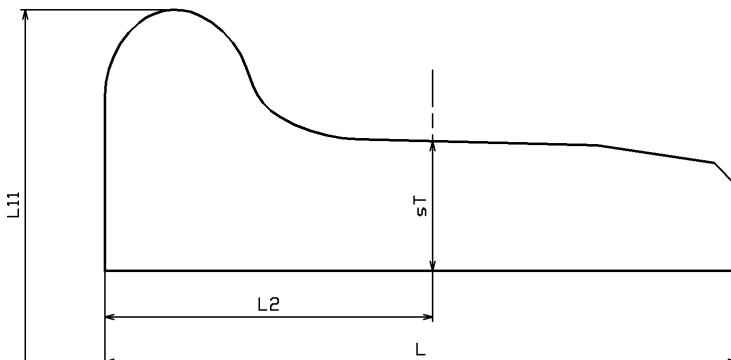
Rim width	L	is calculated as a distance measured vertically between the internal and the external basic wheel surface.
Rim thickness	sT	is calculated as a distance measured vertically between the internal rim diameter and a point on the wheel rolling circle located on any preset distance L2 away from the wheel face. L11 is an external wheel diameter.
		

10.7. Wheel diameter

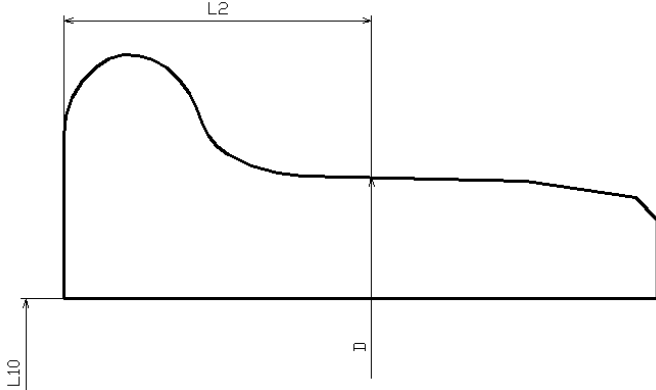
Diameter	D	is calculated by the formula: $D = 2 \cdot T + L10$, T – rim thickness L10 – diameter of the wheel center
		

10.8. Tram wheel parameters

The following parameters of the tram wheels profile are calculated automatically:

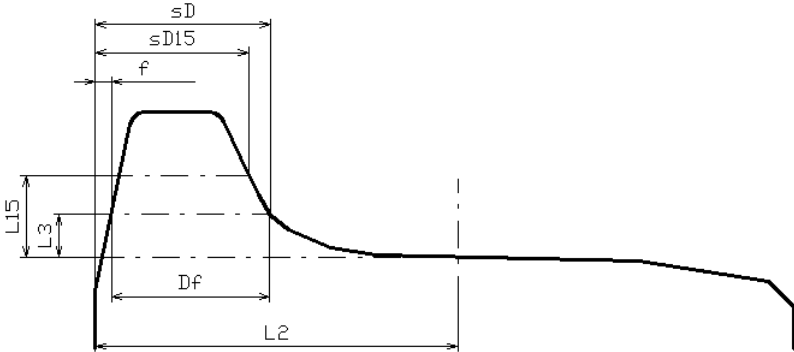
Flange thickness	sD15	is calculated as a distance measured horizontally at the set height (L15) between two points: 1st point is at the internal flange surface, 2nd point is at the line lying on the internal face of the wheel surface.
Flange thickness	Df	is calculated as a distance measured horizontally at the set height (L3) from the surface of the wheel rolling circle between two points lying on opposite sides from the flange top.
Reverse slope	f	is calculated as a distance measured horizontally from the point on the internal flange side at the set height (L3) to the point on the line lying on the internal face of the wheel.
		

10.9. Wheel defects

The following parameters of defects of the wheel surface are calculated:

Slide	sP	is calculated as a difference of the wear measurements in two places of the wheel: on the slide and close to it (in the place without defects) at the point on the wheel rolling circle at any preset distance (L2) from the wheel face.
Cavity size	hR	is calculated as a difference of the wear measurements in two places of the wheel: on the cavity and close to it (in the place without defects) at any profile point.
Cavity area	sR	is calculated in the place of the maximum deviation.

11. Coordinate system

When comparing the profiles, two variants of location of the coordinate system of the wheel is possible to use.

Coordinate system origin	
<p>Top</p> <p>When comparing and displaying profiles, the coordinate system origin is located at the intersection point of lines passing through the profile top and the internal wheel surface.</p>	
<p>Wheel rolling circle</p> <p>When comparing and displaying profiles, the coordinate system origin is located at the intersection point of lines passing through the wheel rolling circle.</p>	

19

12. Adding and selecting the measurement device

By default, the PDA is configured to work with the IKP, IDK-VT and IMR devices with which it is supplied. To add a new device, you must follow the following instructions: go to the **Gauges** menu, for which you need to press , or swipe your finger from the left edge of the case to the center of the screen.

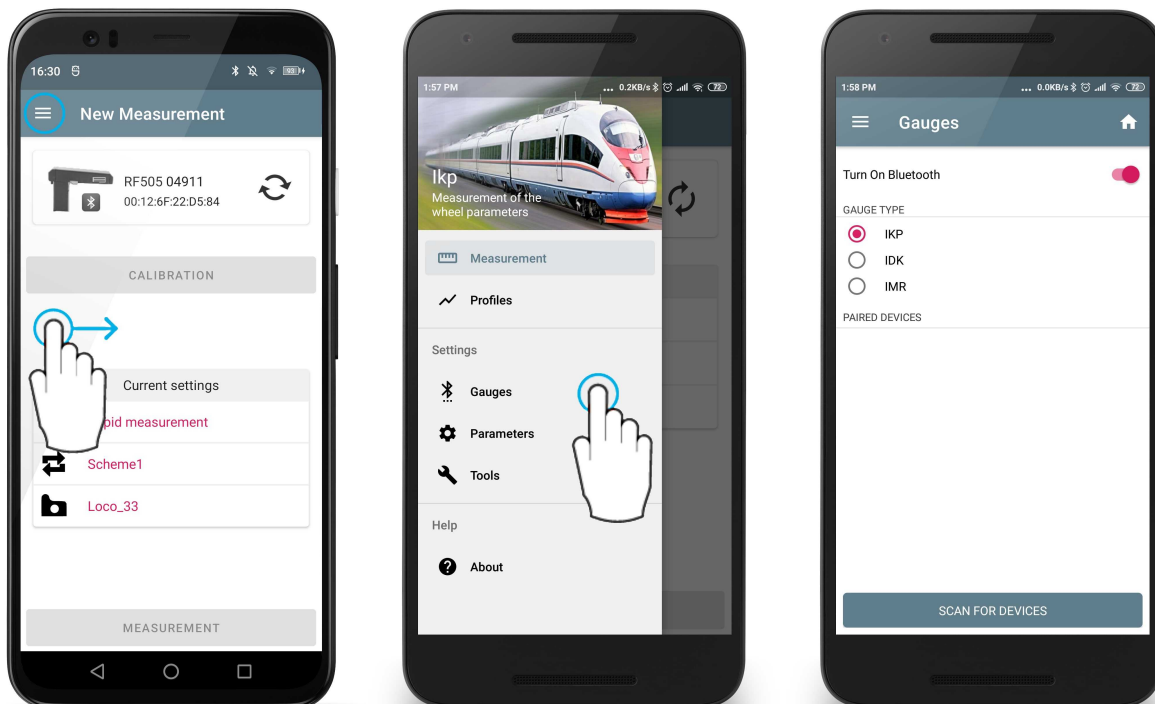

In the **Gauges** window, you can turn on/off Bluetooth, select the type of measuring gauge (by default, IKP) and add a new measuring gauge depending on the selected type.

To add IKP, turn on the laser module and tap **SCAN FOR DEVICES**.

On the first search, the app will ask you to access the device's location data. To start the search, you need to tap **ALLOW**.

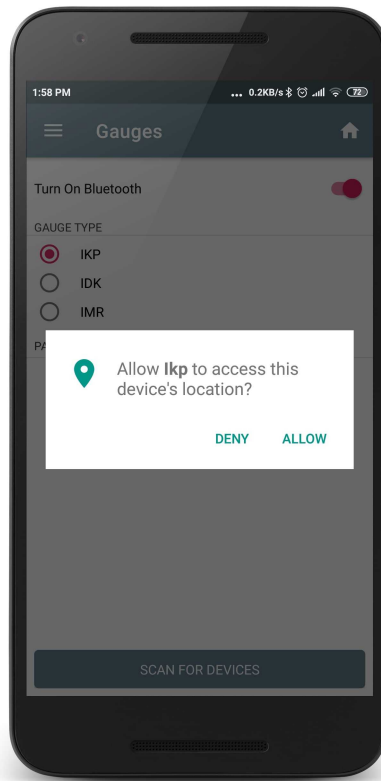

20

If you tap **DENY**, device search will not be available and the following message will be displayed:

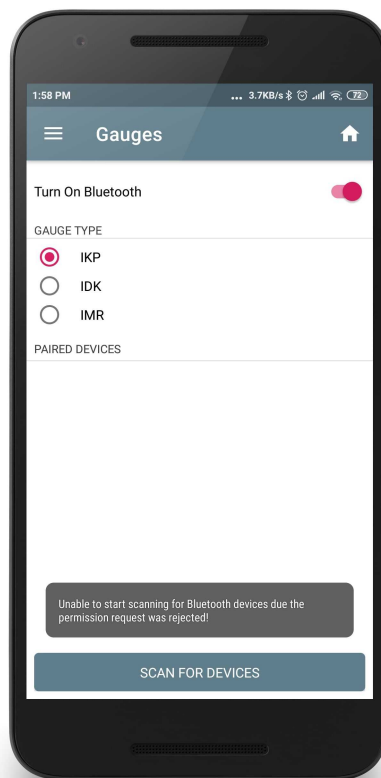

If the search is successful, the gauge will be added to the **AVAILABLE DEVICES** list and then, for pairing, you need to tap on this device.

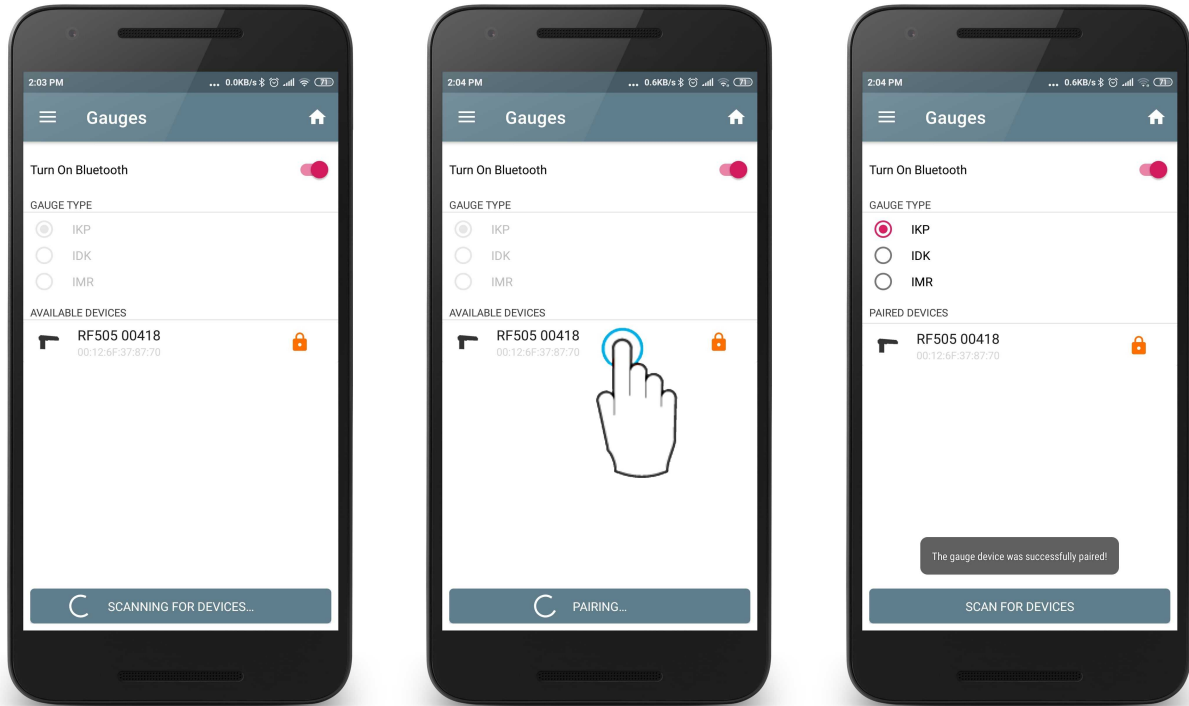

The device will be paired, but locked for selection as the primary for synchronization (🔒). To unlock and select it as the main one, you need to swipe left from the right edge and tap the **Select** button.

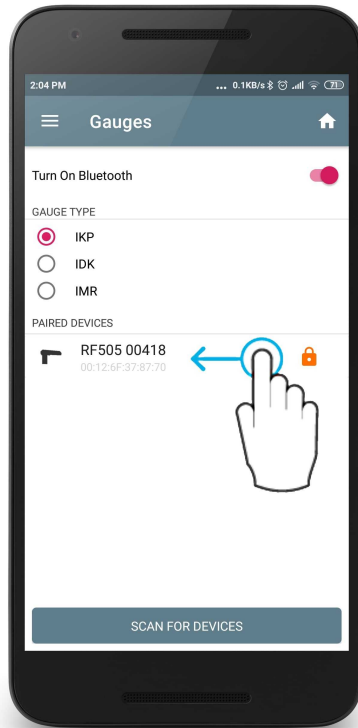

In the window that appears, enter the key to unlock the device or scan the QR code. A unique key or QR code is supplied with the measuring gauge or upon request. If the key is incorrect, an error message will appear.

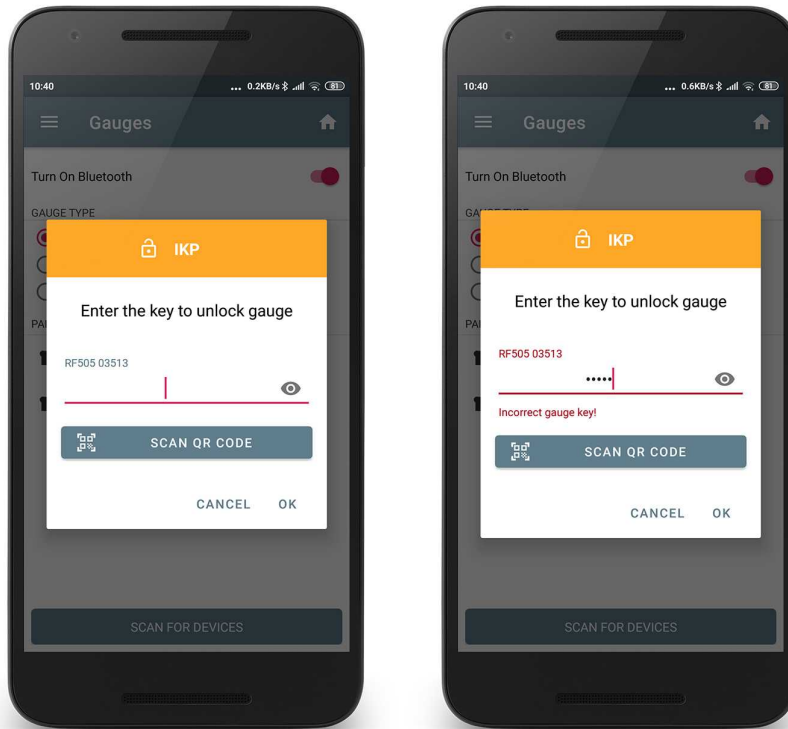

To scan a QR code, you must allow the app to take photos and videos.



Allow Ikp to take pictures and record video?

DENY ALLOW

If the correct key is entered, the lock icon will disappear and a check mark (✓) will appear next to the selected device.

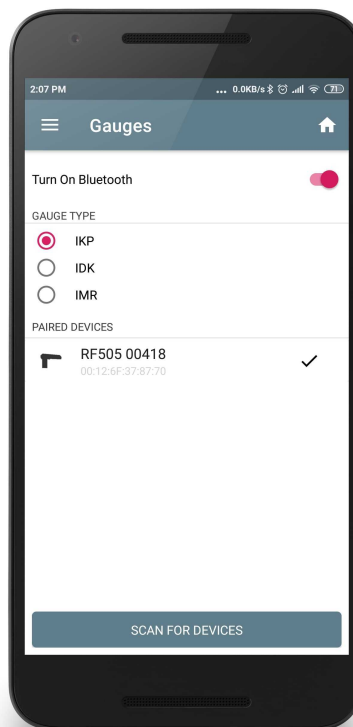

The selected device will be connected automatically after starting the application.

If the required device is in the list (and unlocked), you just need to select it.

23

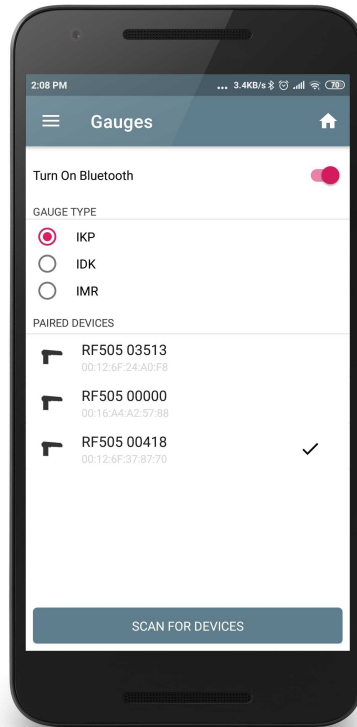

If the measuring gauge is no longer in use, you can remove it from the list of available devices by canceling the pairing. To do this, swipe left from the right edge and tap the **Delete** button.

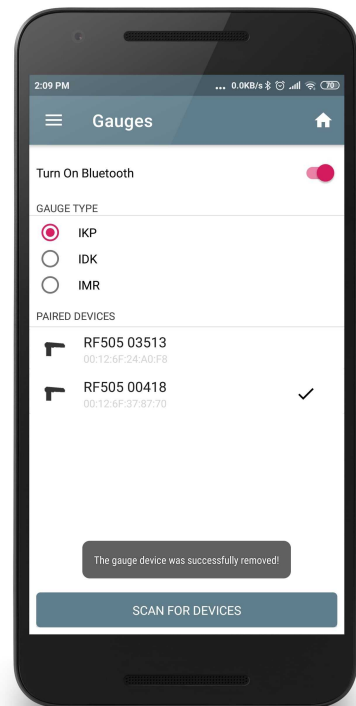
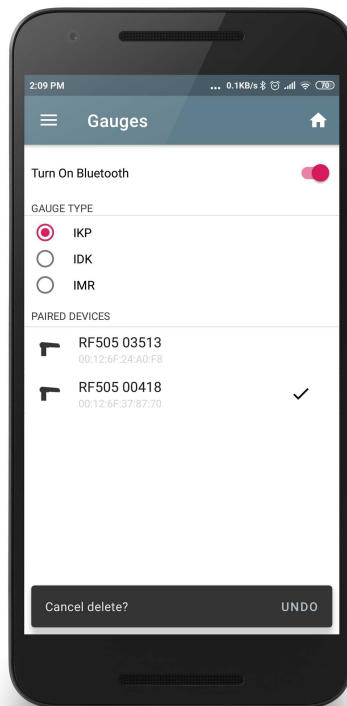
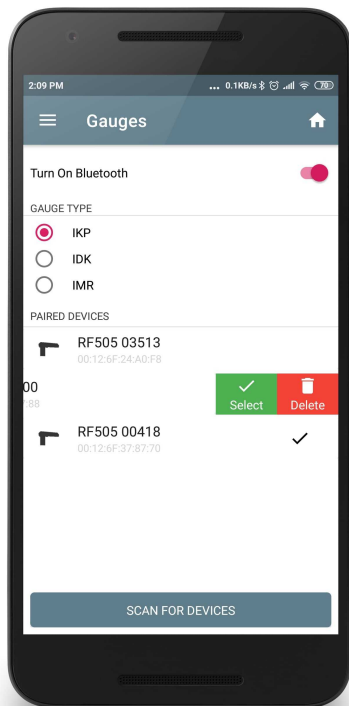

To add another measuring gauge (IDK, IMR), follow the same steps.

13. PDA program setting

Before you start working with gauges, you need to configure the software. To do this, select the **Parameters** item in the main menu:

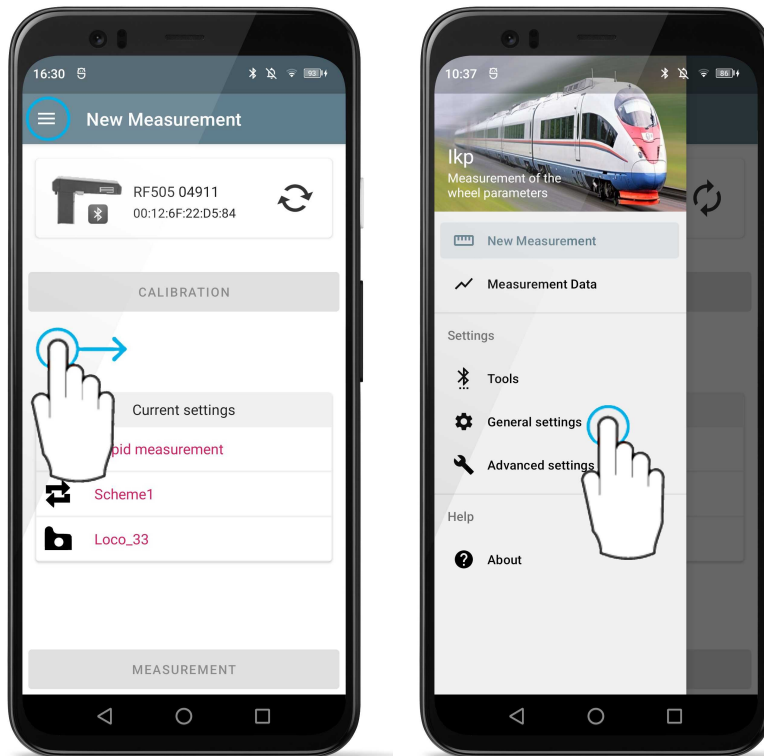

13.1. Setting general parameters

Selecting **General settings** opens a window for setting up an Access password and Bluetooth connection:

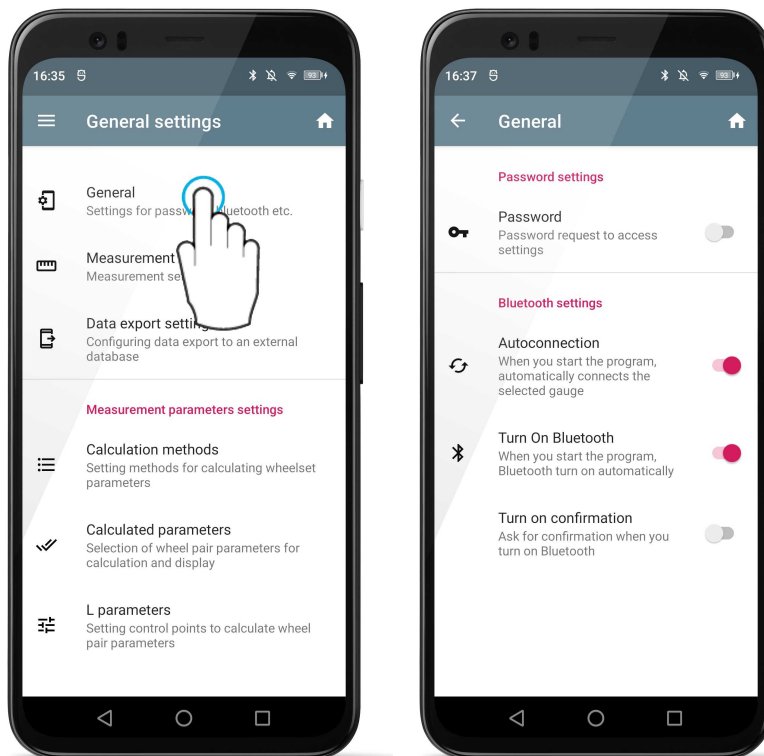

13.1.1. Setting a password

The **Password settings** section allows the user to set a password to access all basic settings.

25

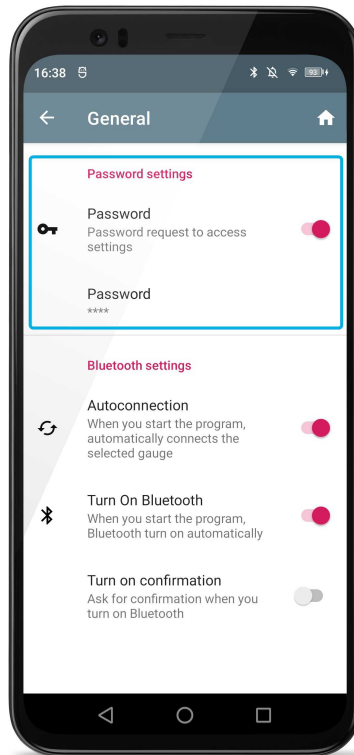

To set a password, select the **Password** item, enter the password and confirm it. By default, the password is "1111".

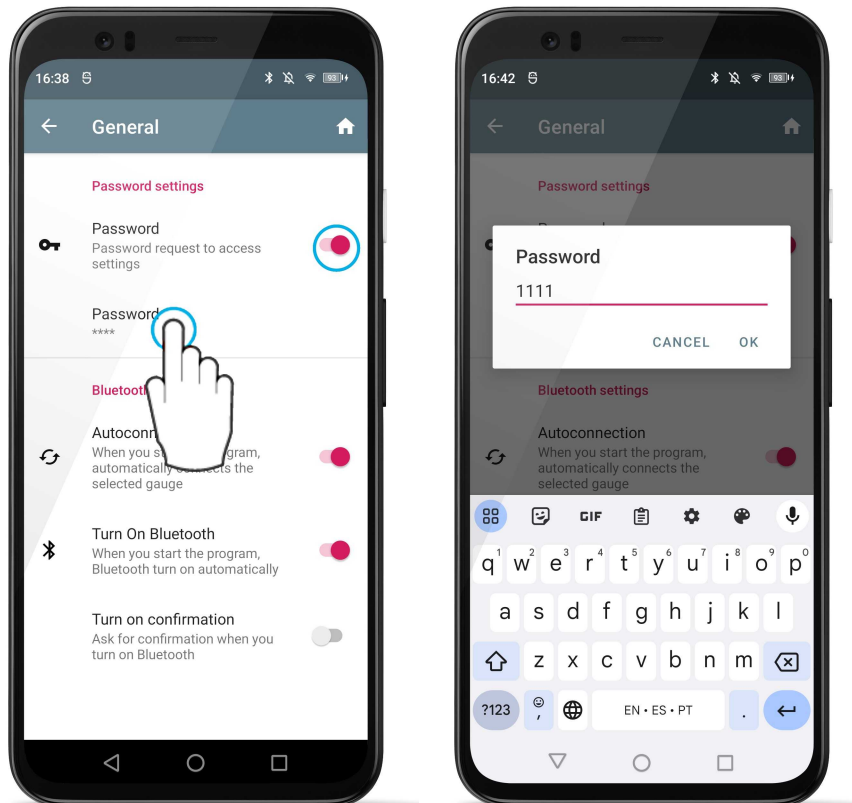

13.1.2. Bluetooth settings

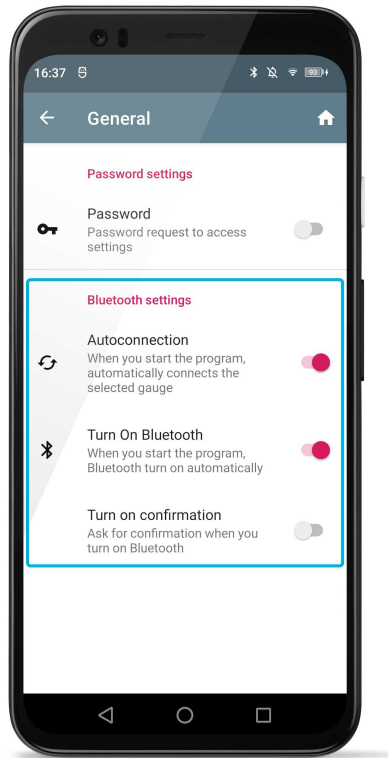

Autoconnection - if this option is enabled, then at startup the application will try to connect to the measurement device that is selected in the settings (see par. [Adding and selecting the measurement device](#)).

If this option is disabled, then you must tap on the synchronization icon in the main program window in order to establish a connection to the device.

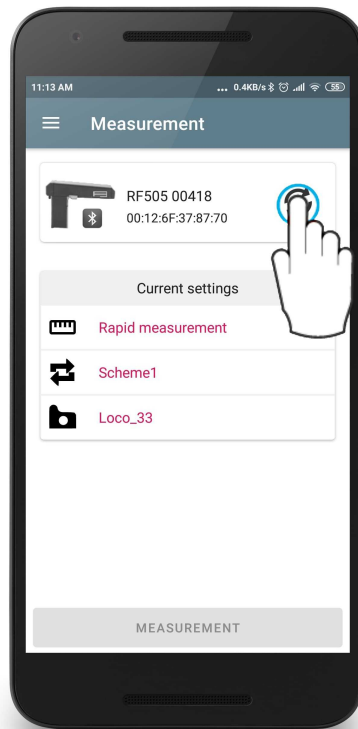

Turn on Bluetooth - if this option is enabled, then at startup the application will automatically check if Bluetooth is enabled, and if not, enable it.

If this option is disabled, it will be necessary to manually enable Bluetooth each time you start the app in order to connect to the measuring gauge.

Turn on confirmation - this option becomes available only if the **Turn on Bluetooth** option is selected. If the option is enabled, the app will ask for confirmation to turn on Bluetooth.

27

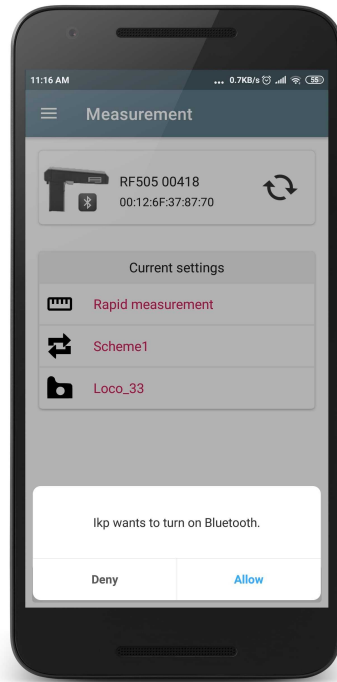

13.1.3. Change the program language

Changing the program language is performed upon request to the manufacturer (info@riftek.com) and is a free service.

13.2. Setting general measurement parameters

Selecting the **Measurement** item opens a window for setting measurement parameters.

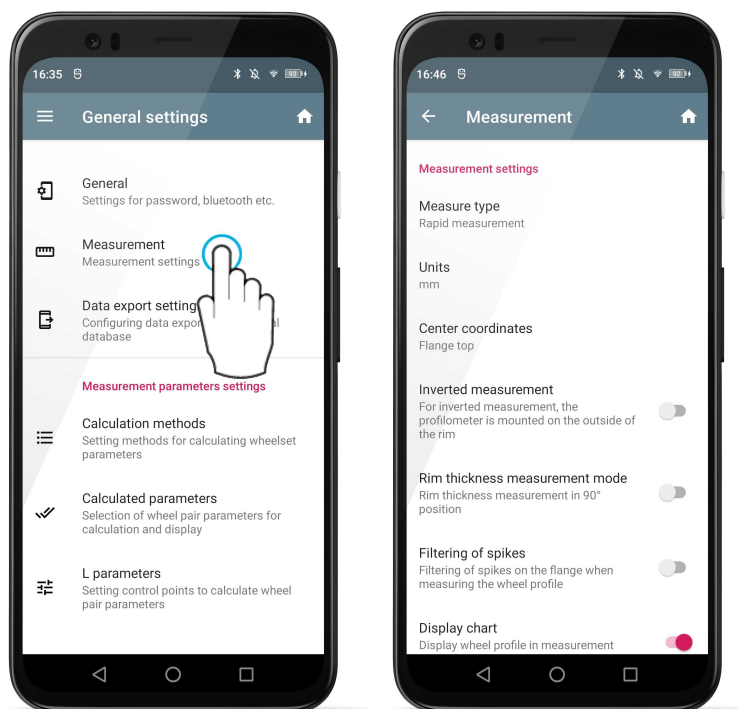

Measurement type - see the next chapter

Units - select mm/inch.

Inverted measurement - if this option is selected, the profilometer is installed on the outer base surface of the wheel during measurement.

Rim thickness measurement mode - if this option is selected, the profilometer allows you to measure the thickness of the rim when installed on the inner surface of the wheel in the 90° position

Filtering of spikes- if this option is selected, additional data filtering is introduced during measurement to smooth out the dents on the wheel surface.

Display graph - this option allows you to display an image of the measured wheel profile.

13.2.1. Setting the measurement type

To set the measurement type, tap the **Measure type** item and select **Rapid measurement** or **Measurement by scheme**.

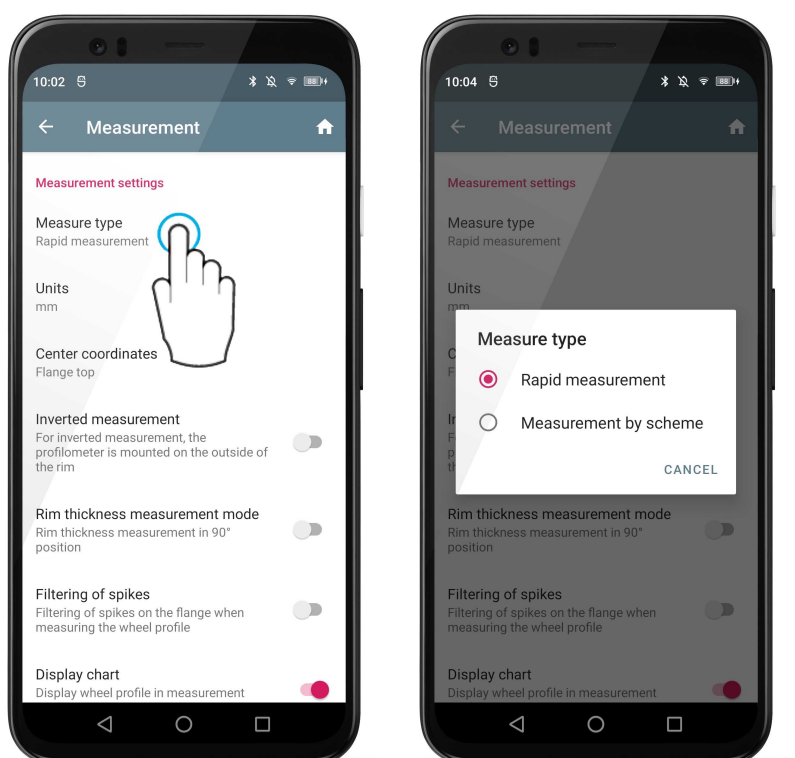

13.3. Setting up data export

Selecting the **Data export settings** item opens a window for setting options for exporting saved data:

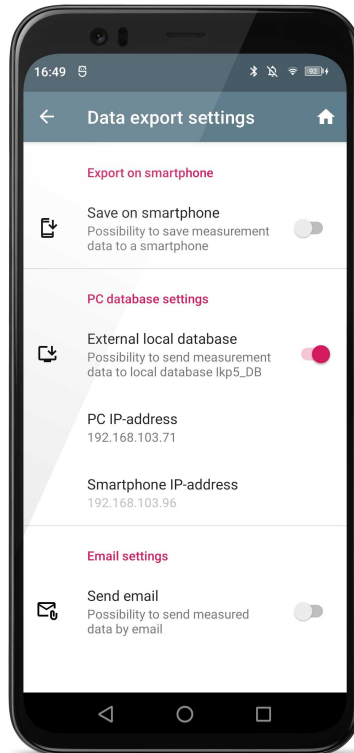

13.3.1. Export to PDA

To enable the ability to save a data file on your PDA, you need to set the **Save to smartphone** option.

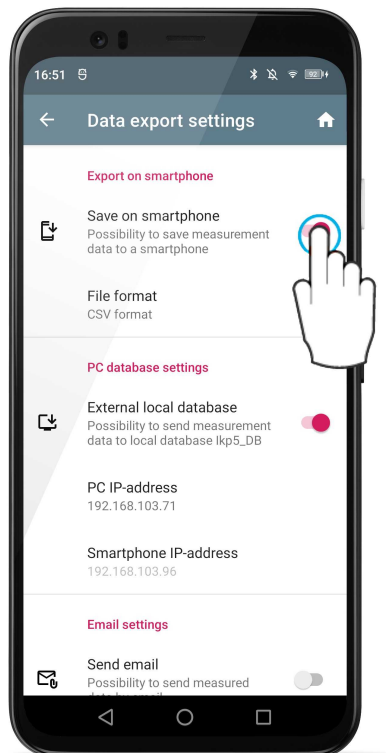

Next you need to select the file format (CSV, XLS, XML, WHL).

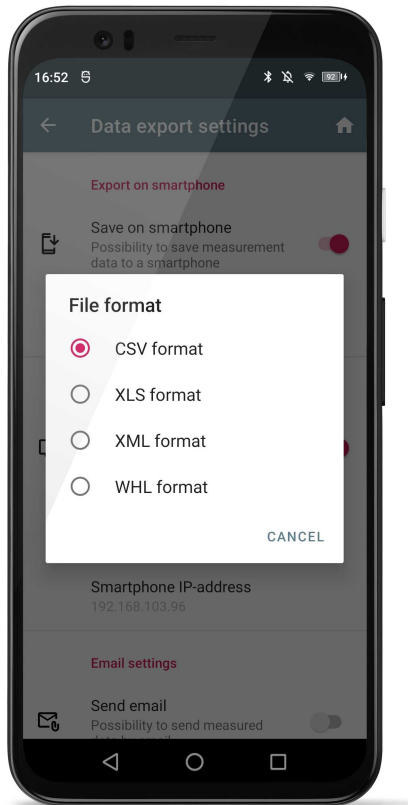

13.3.2. Export to PC data base

To enable the ability to export data, set the **External local database** option

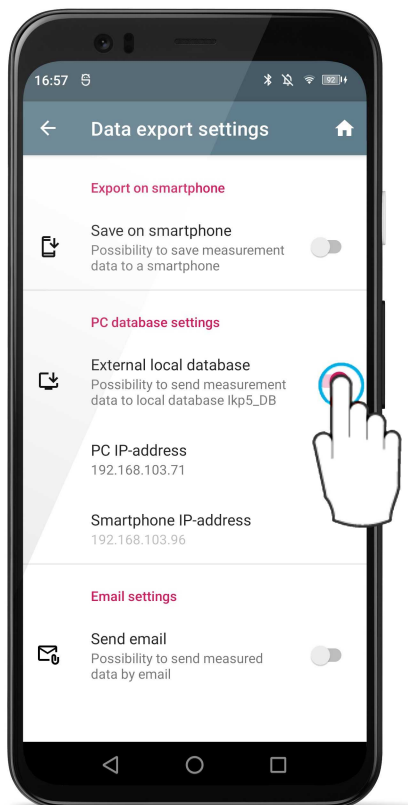

To transfer data between a PDA and a PC, you need to configure the IP address of the PC. Data exchange is carried out via Wi-Fi. The PC and PDA must be connected to the same Wi-Fi network. This can be a dedicated network created on an Android device (virtual hotspot) or any home/work network.

13.3.2.1. PC server settings

To transfer data to a PC, you need to specify the port and IP address of the server that is running in the **lkp5_DB** program (download link: https://riftek.com/upload/iblock/f57/lkp5_PC_Software.zip).

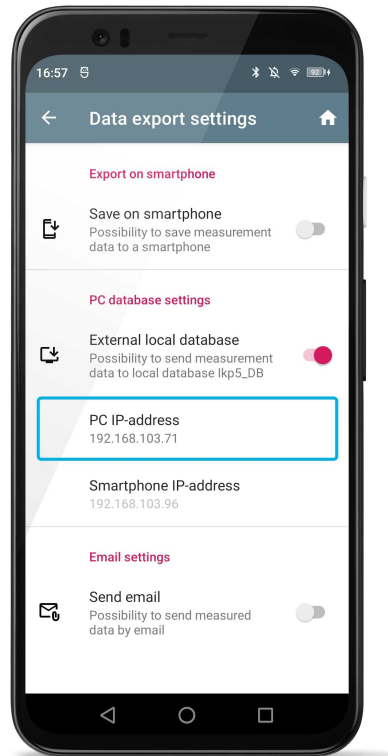

The IP address can be found on the PC. There are two ways to find your IP address on Windows.

Method 1. Find the IP address using the **Settings** app (Windows 10).

1. Select **Start > Settings**.

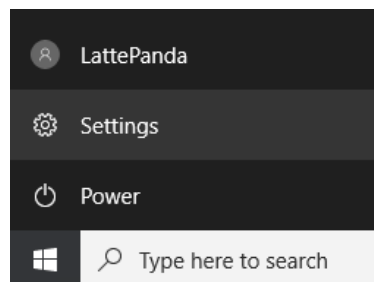

2. Select **Network & Internet**.

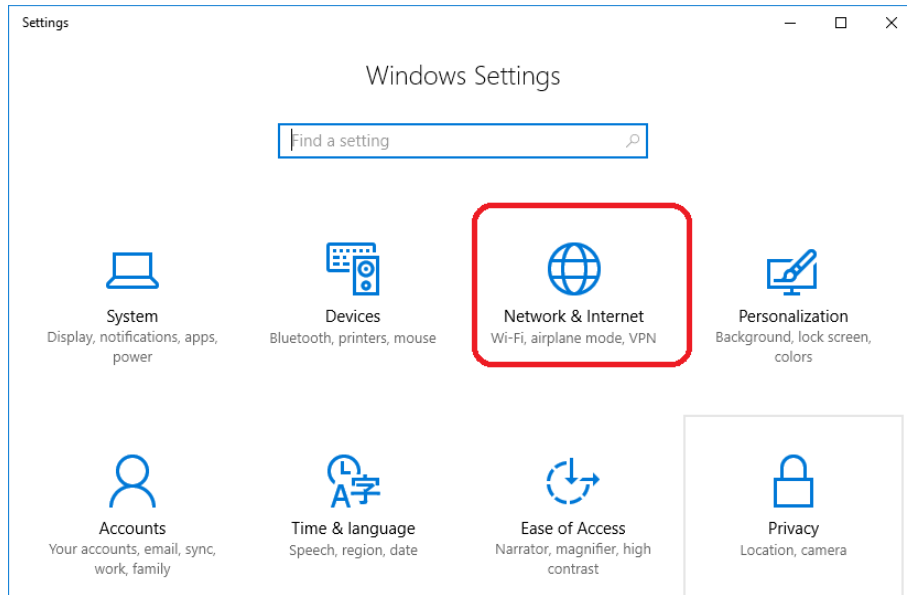

3. In the left panel, select **Wi-Fi**.

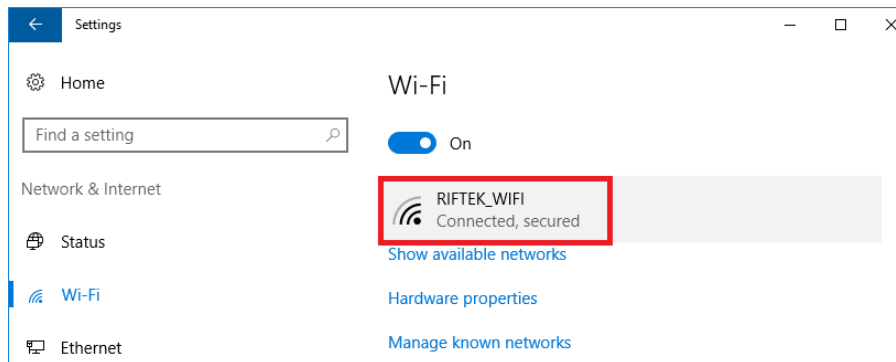

4. Click on your network name.

5. Scroll down to the IPv4 address - this is your IP address.

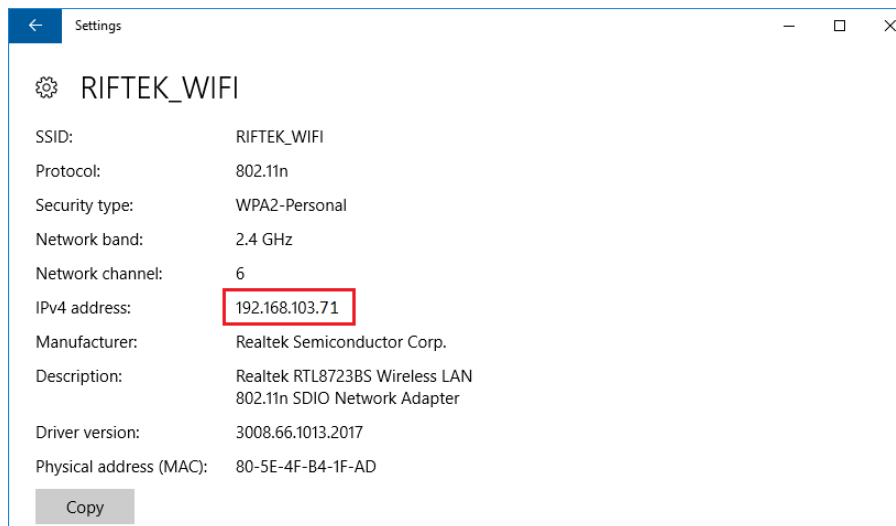

Method 2. Find the IP address using the command line.

1. Click **Start**, type *cmd* in the search bar and press **Enter**.

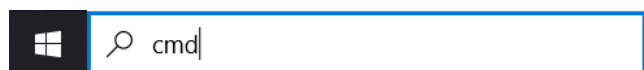

2. Type *ipconfig* and press **Enter**.

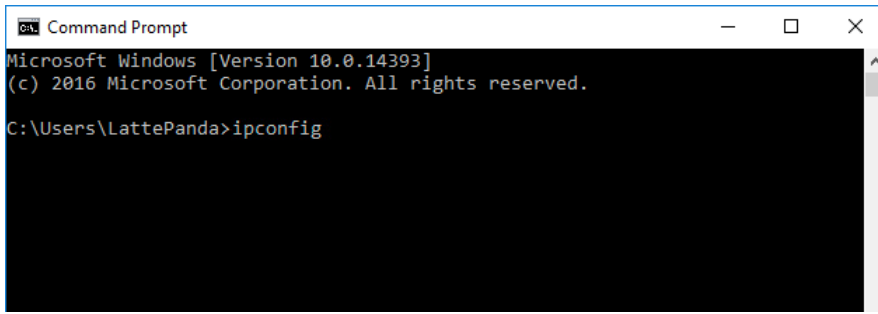

3. Find the IPv4 address - this is your IP address.

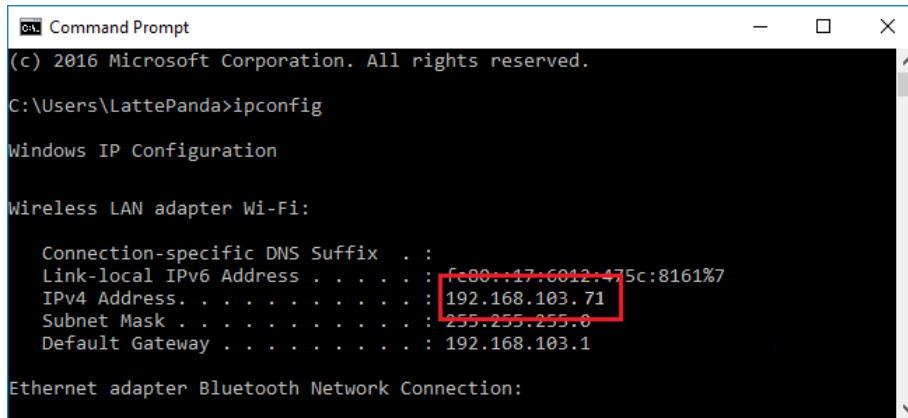

This IP address must be specified in the PC server settings. The port number is the same as in the settings of the **lkp5_DB** program on the PC (see [Synchronization of a mobile device and a PC](#)).

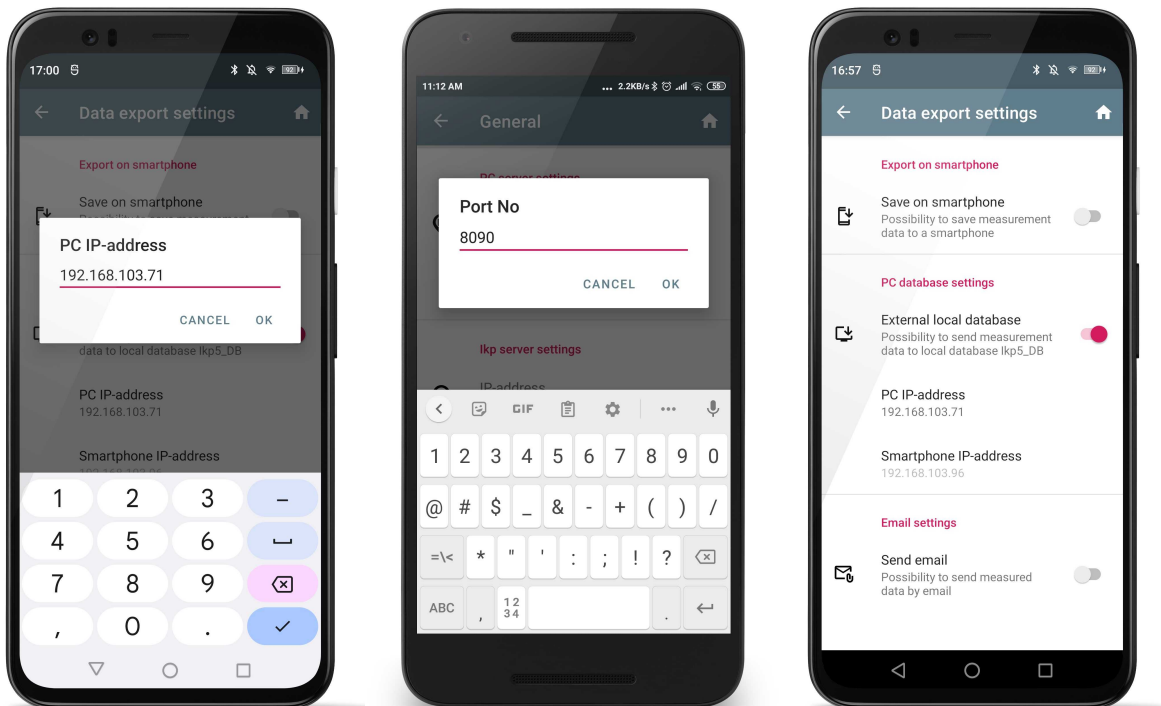

13.3.2.2. PDA server settings

A server on PDA is needed to transfer reference files and processing scheme files from the **lkp5_DB** program.

The **IP address** field is unavailable for editing, it displays the IP address of PDA in the Wi-Fi network. This IP address is used in the settings of the **lkp5_DB** program (see [Synchronization of a PDA and a PC](#)).

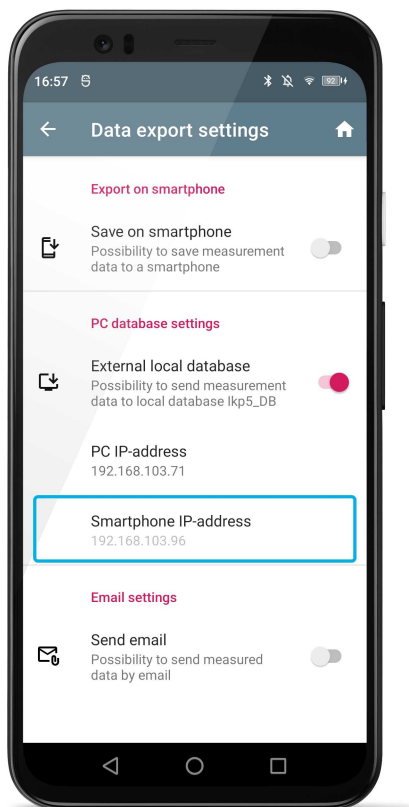

13.3.3. Sending data by email

To enable the ability to send a data file via Email, check the **Send email** option.

35

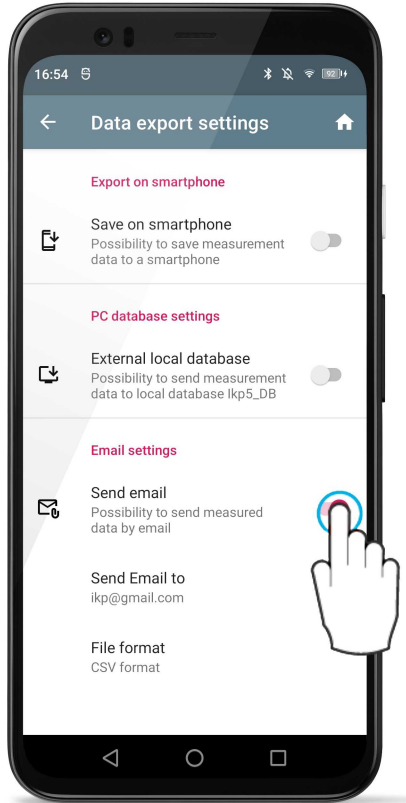

To send data, you need to enter the recipient's address and select the format of the sent file (CSV, XLS, XML, WHL).

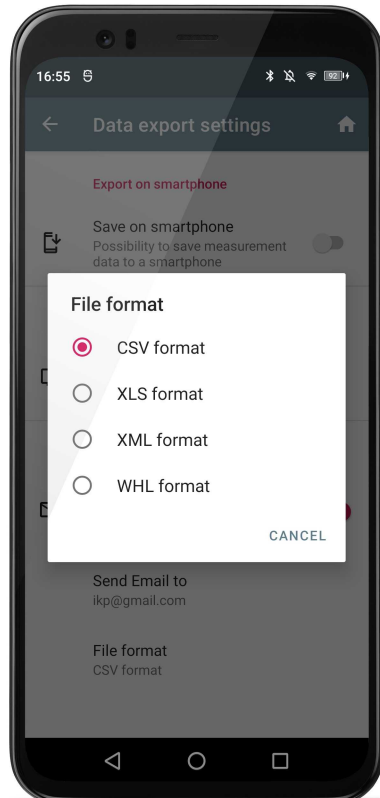
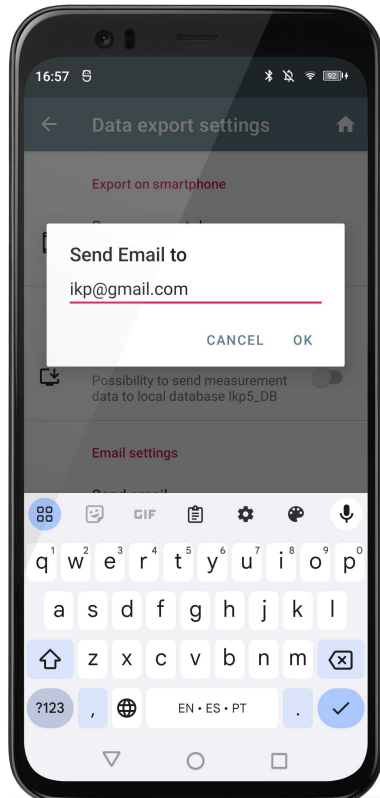

13.4. Setting IKP measurement parameters

The menu item **Measurement Parameter Settings** is responsible for the settings for calculating the controlled wheel parameters.

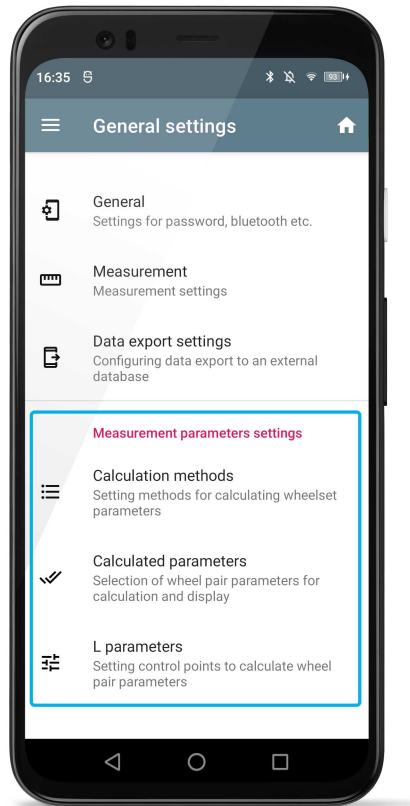
**36**

Calculation methods - setting up methods for calculating wheel sets parameters.

Calculated parameters - selection of wheel set parameters for calculation and display.

L parameters - setting the values of reference points for calculating the parameters of wheel sets.

13.4.1. Calculation methods

Select the **Calculation methods** item:

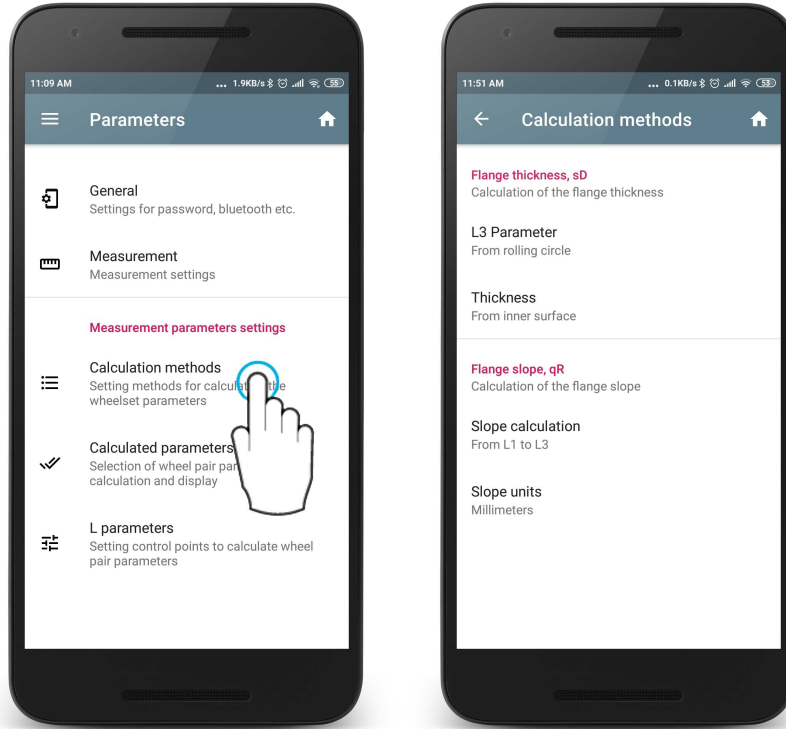

Methods for calculating parameters are described in the previous paragraphs..

13.4.2. Calculated parameters

Select the **Calculated parameters** item:

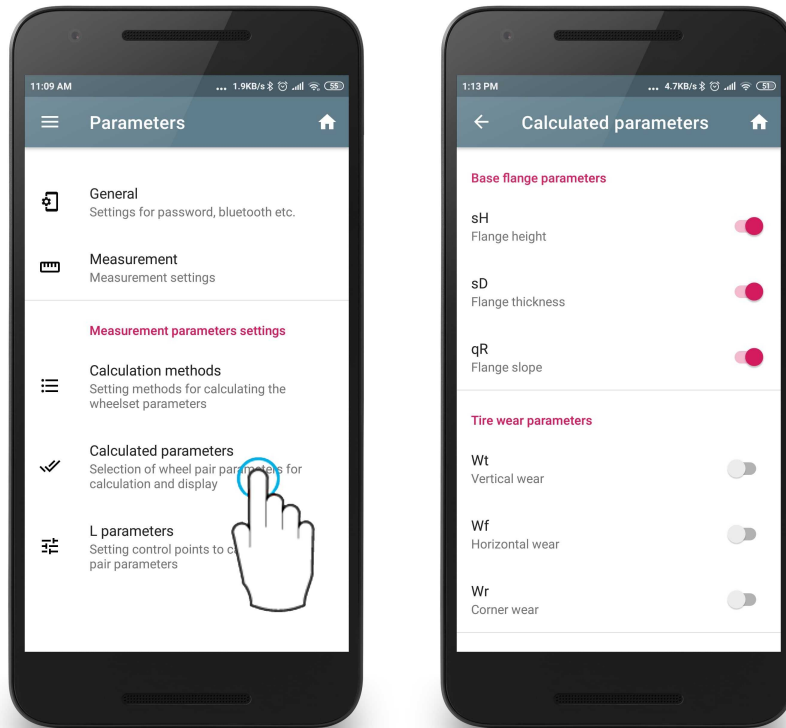

To select / deselect a parameter, tap the parameter.

13.4.3. L parameters

Select the **L parameters** item:

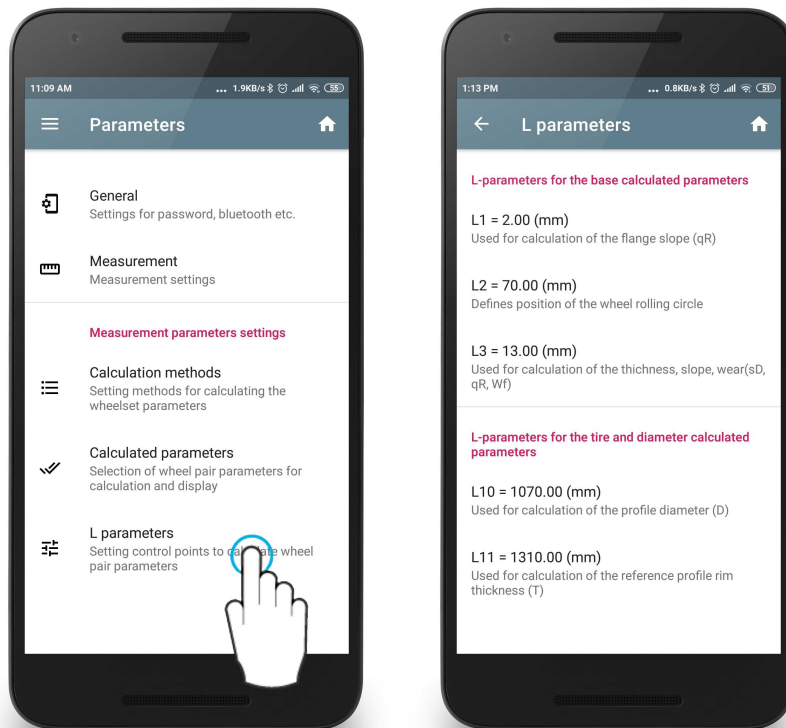

The table displays only those parameters that are necessary for calculating the selected geometric parameters of the wheel (see par. [Calculated parameters](#)).

To edit a parameter, tap on the parameter and enter a new value in the window that appears. After entering, tap **OK**.

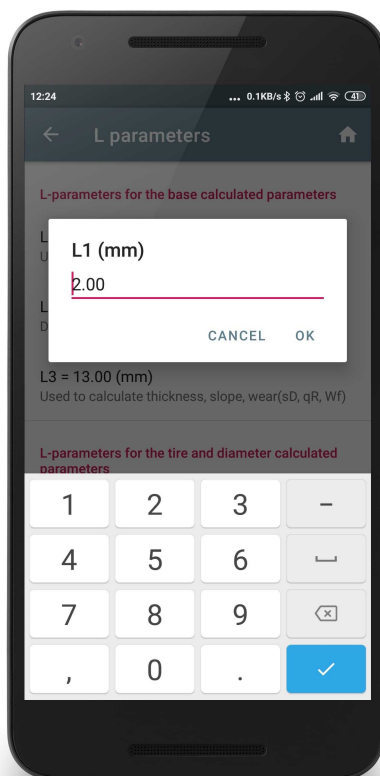

13.4.4. Preset values

L parameter	Default value	Assignment
L1	2 mm	It is used to calculate the flange slope (qR).
L2	70 mm	It sets the position of the wheel rolling circle and is used to calculate: <ul style="list-style-type: none"> - flange height (sH); - flange thickness (sD); - flange slope (qR); - inclination angle (A); - wheel diameter (D); - rim thickness (T); - wear (Wt, Wf, Wr).
L3	13 mm	It is used to calculate: <ul style="list-style-type: none"> - flange thickness (sD); - flange slope (qR); - wear (Wf).
L4	13 mm	Additional point for calculating the flange slope (qR).
L5	10 mm	It is used to calculate the angular wear (Wr).
L6	70 mm	It is used to calculate the slope of the rolling surface (S1).
L7	105 mm	It is used to calculate the slope of the rolling surface (S2).
L8	10 mm	It is used to measure the inclination angle of the profile at the desired point (A).
L9	140 mm	It is used when the measurement direction is inverted (L9 - profile width).
L10	599.35 mm	It is used to calculate the profile diameter (D).
L11	767 mm	It is used to calculate the rim thickness of the reference profile (T).
L15	13 mm	It is used to calculate the flange thickness of tram wheels (sD15).
P7 P8	70 mm 110 mm	It is used to calculate the hollow (HI).
D1 D2	70 mm 107.5 mm	It is used to calculate the difference in wheel diameters in different sections (DD).

14. Setting reference profiles, measurement schemes, tolerances

Swipe right from the left edge and select **Tools**.

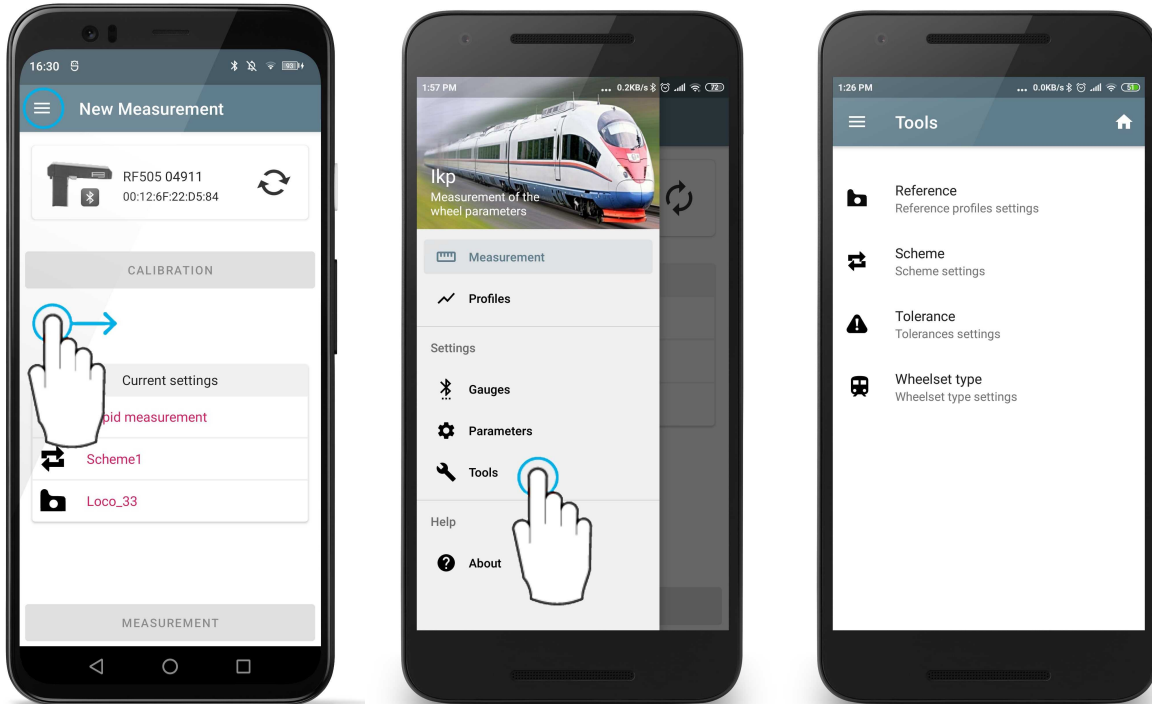

40

- Reference** - selection of reference profile.
- Scheme** - measurement scheme settings.
- Tolerance** - tolerance settings.
- Wheelset type** - wheelset type settings.

14.1. Reference profile

The program allows you to compare the scanned wheel profile with the reference profile.

14.1.1. Selecting and deleting the reference profile

To select a reference as the main one, you need to swipe left from the right edge and tap **Select**. The selected reference will be marked with ✓.

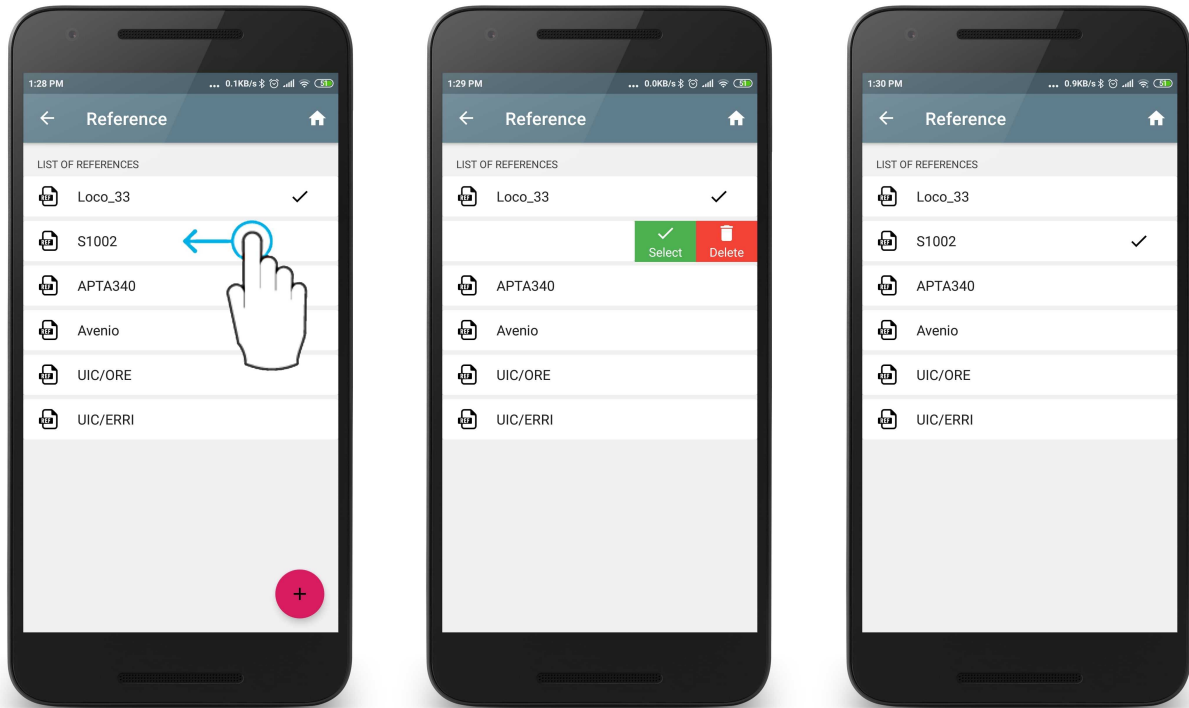

To delete one reference, you need to swipe left from the right edge and tap **Delete**.

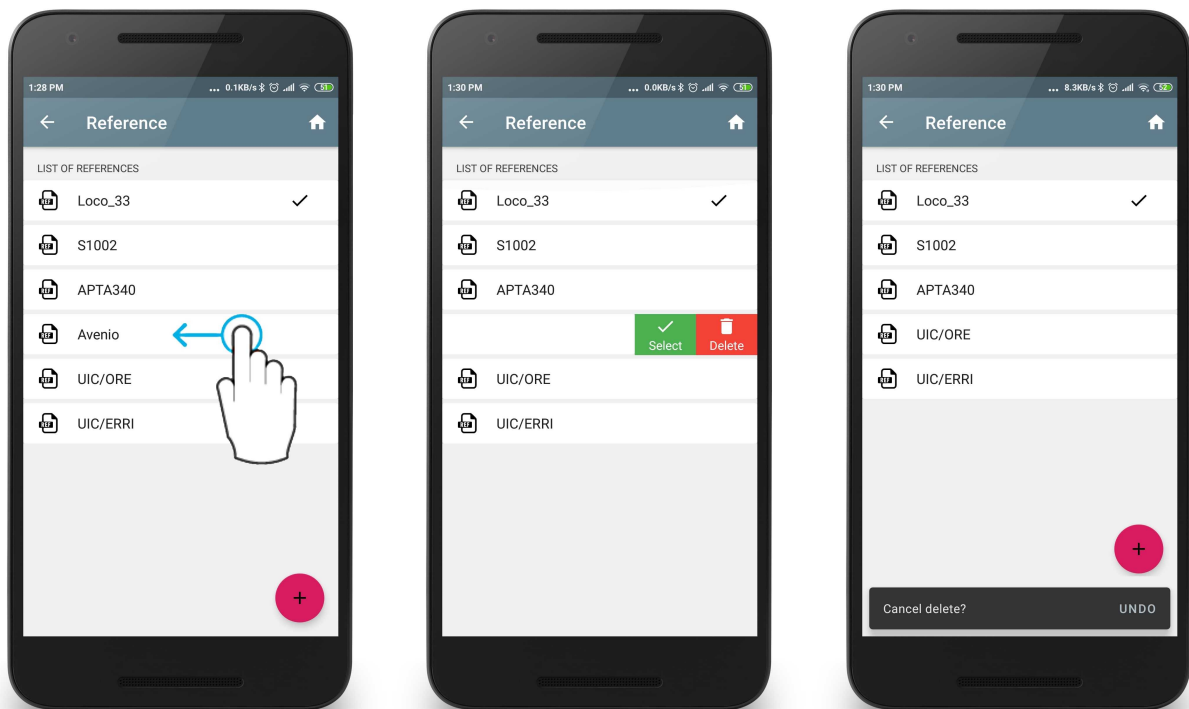

To delete several or all references, you need to tap and hold the item. Multiple selection mode will start.

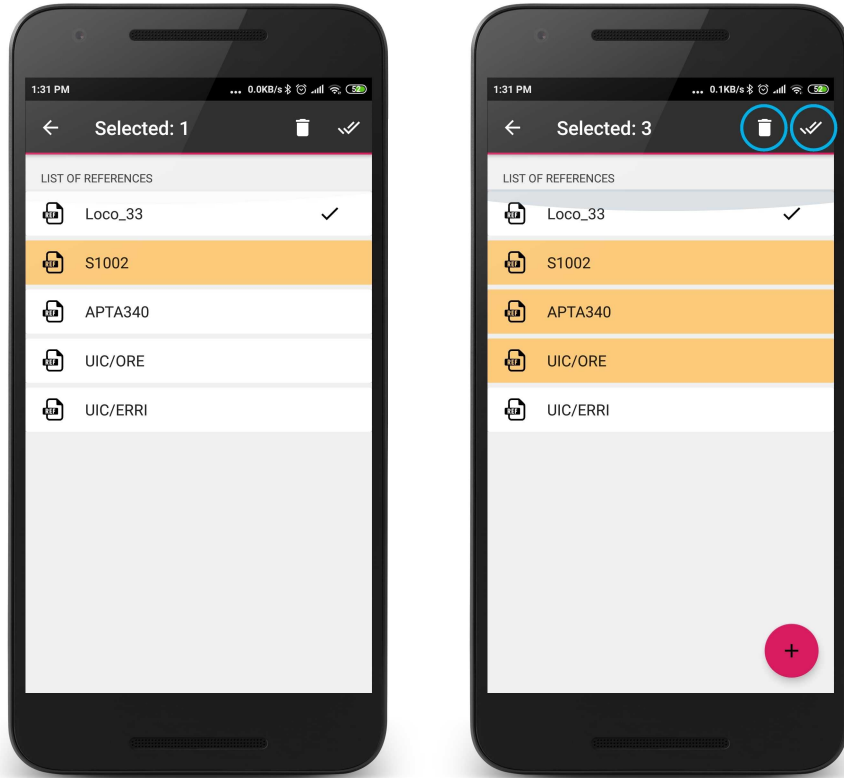

Buttons:

 - delete the selected references;

 - select all.

To view the profile and reference parameters, you must tap on the required item.



14.1.2. Uploading the reference profile to the database

The app comes with several pre-installed reference profiles.

If the required reference profile is not in the database, the user can request RIFTEK (free service) and then add the profile.

There are three ways to add a new reference to the database:

1. Copy the reference file to the device (in any standard way) and tap . Select the files you need and tap **Select**.

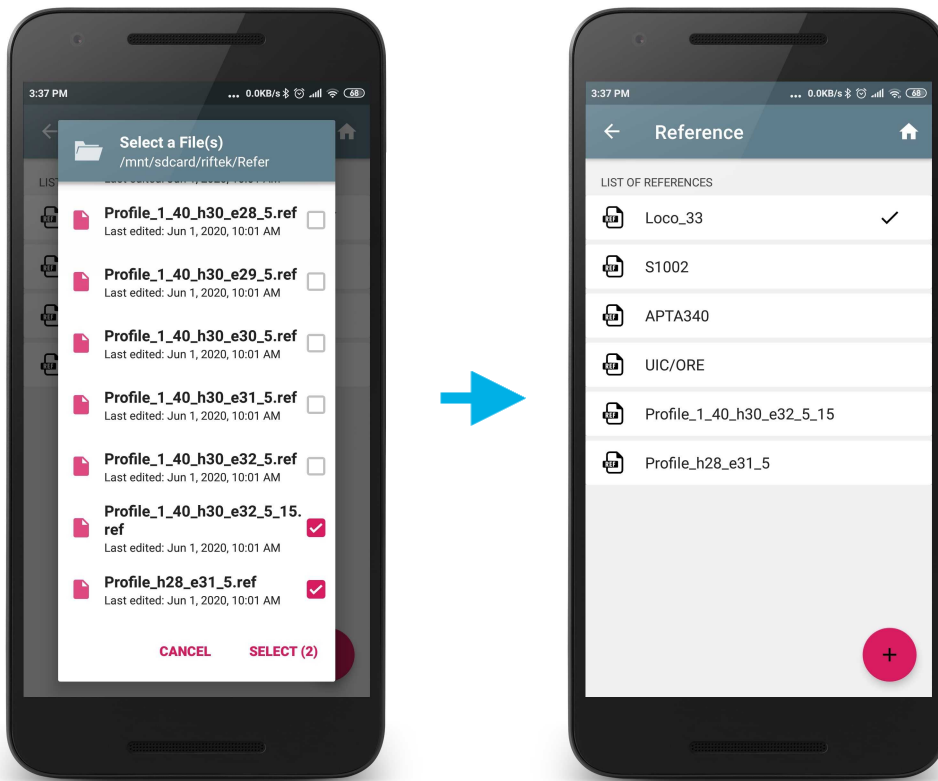

2. Export a profile from the database of measured profiles (see par. [Saving the wheel profile as the reference](#)).

3. Export the reference file from the **lkp5_DB** program to a PC (see par. [Transferring the reference file](#)).

14.2. Measurement scheme

The measurement scheme is the sequence of measurements of the wheels of the rolling stock with the given parameters of each wheelset (wheelset number, car number, series, etc.). The program automatically prompts the operator to measure a specific wheel in accordance with the selected scheme. The program contains several pre-installed schemes.

14.2.1. Selecting and deleting the measurement scheme

To select a scheme as the main one, you need to swipe left from the right edge and tap **Select**. The selected scheme will be marked with ✓.



In the figure, the arrows show the direction of measuring the wheelsets, as well as the names assigned to the wheels (1L - first axle, left side; 2L - second axle, left side; 1P - first axle, right side, etc.).

To delete one scheme, you need to swipe left from the right edge and tap **Delete**.



To delete several or all schemes, you need to tap and hold the item. Multiple selection mode will start.

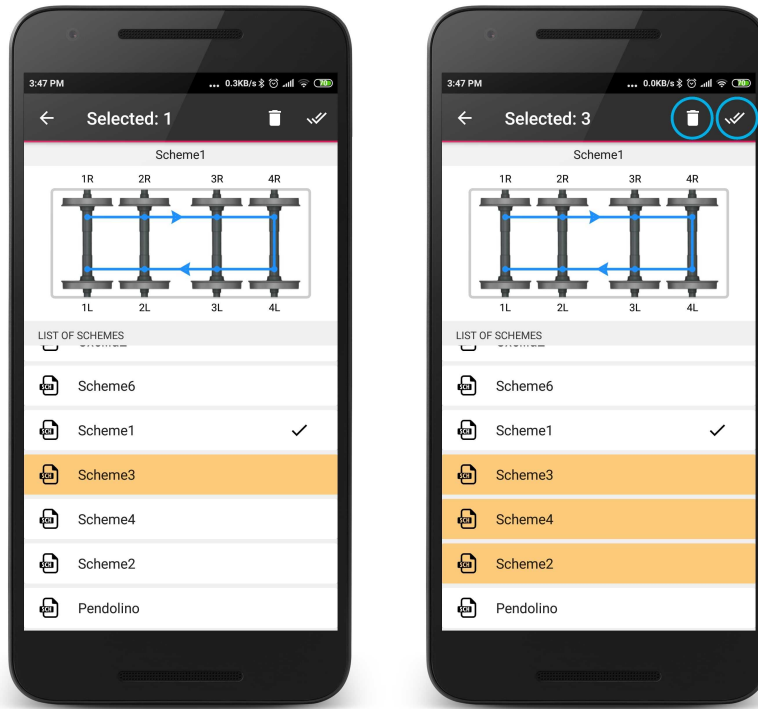

Buttons:

- delete the selected schemes;
- select all.

14.2.2. Uploading a new measurement scheme

The app comes with several pre-installed measurement schemes.

If the measurement scheme is not in the database, the user can generate the scheme himself (see the User Manual for IKP) or request RIFTEK (free service) and then add the scheme.

There are three ways to add a new measurement scheme to the database:

1. Create a new scheme yourself.

To do this, tap and select **Add** from the drop-down menu.

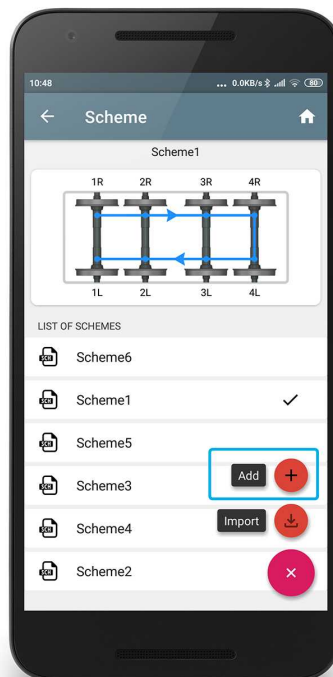

Enter the name of the scheme, the number of cars in the train, the number of axles in each car, and the type of scheme. After entering all these data, tap .



2. Copy the scheme file(s) to the device (by any standard method), tap  and select **Import** from the drop-down menu.

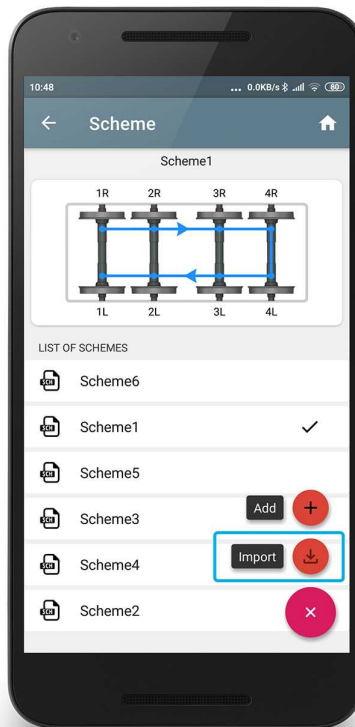

Tick the required files and tap **Select**.

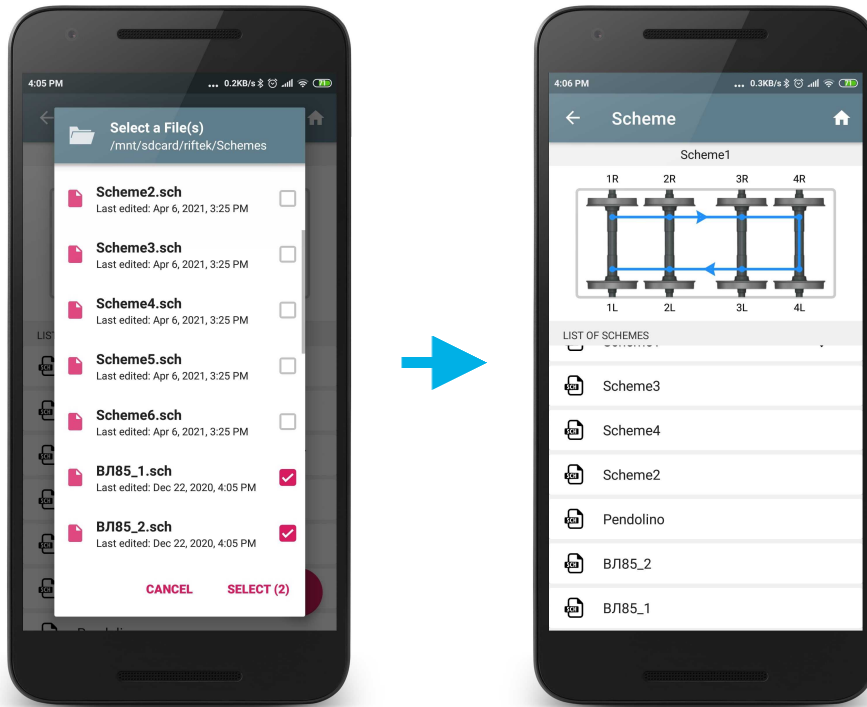

3. Export the scheme file(s) from the **lkp5_DB** program to a PC (see par. [Transferring the scheme file](#)).

14.3. Tolerance

The app automatically controls the measured geometric parameters for going beyond the specified tolerances.

14.3.1. Viewing and deleting tolerances

For each reference profile, you can add the tolerances for the calculated parameters of the wheelset.

The screenshots below show the tolerances for the "Loco_33" and "DMeTILR_33" references. If "Loco_33" is selected as the reference profile, the tolerance will also be used with the name "Loco_33".

To view or edit the values, you need to tap on the name of the tolerance.

The table displays the tolerances only for the selected geometric parameters of the wheel.

The maximum/minimum critical values of the parameters are displayed in red. The maximum/minimum values of the parameters, which are close to the critical values, are displayed in orange.

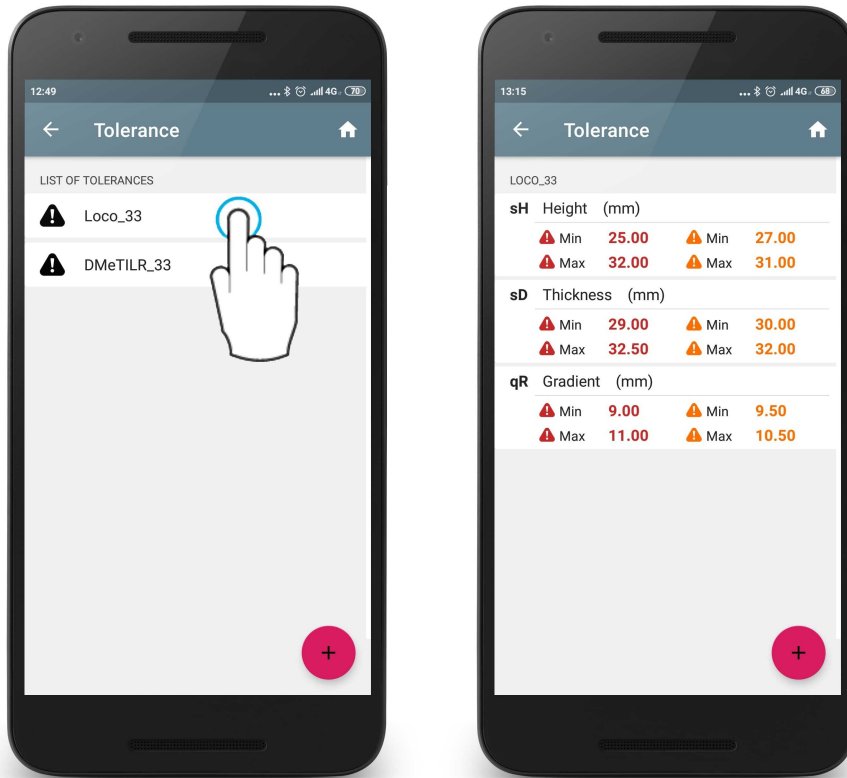

To delete a tolerance, you need to swipe left from the right edge and tap **Delete**, or tap and hold the item with the tolerance name (the procedure is the same as for the references - see par. [Selecting and deleting the reference profile](#)).

14.3.2. Adding tolerances

To add a tolerance, tap  and select a reference for which the tolerance will be set.

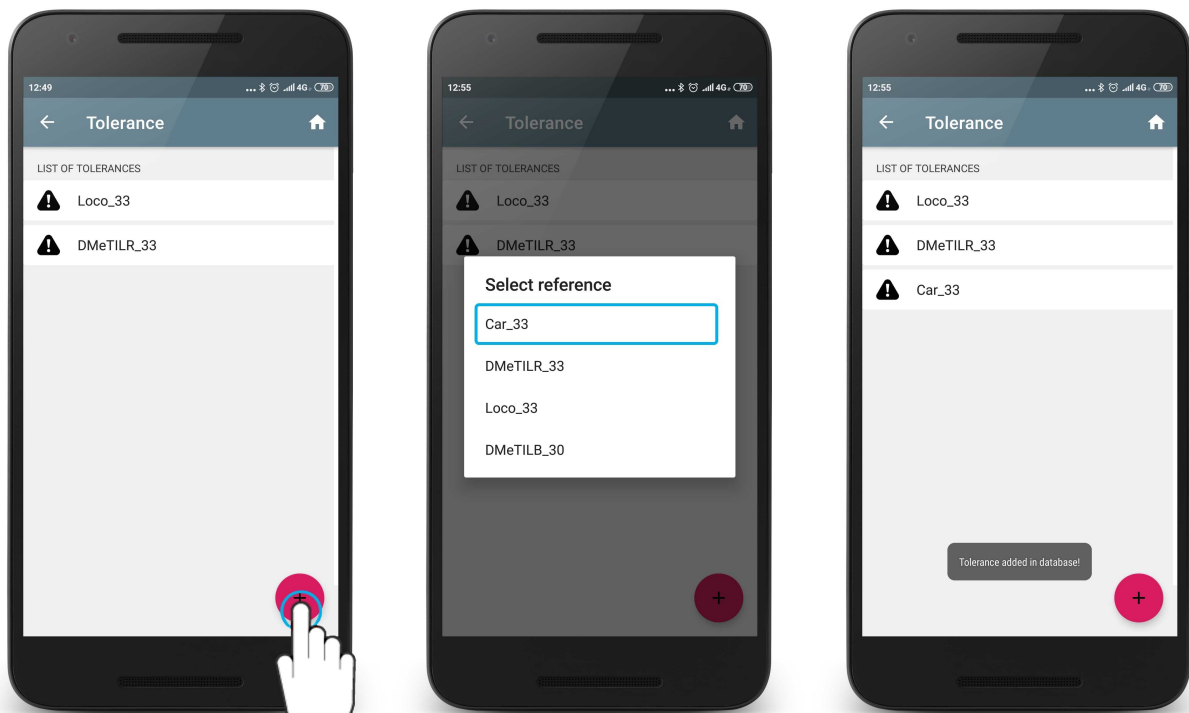

To set the tolerances for the calculated parameters of the wheelset, tap on the tolerance name. Then tap  and select the parameter for which the tolerances will be set. The drop-down list contains only those parameters that are selected for calculation (see par. [Calculated parameters](#)).

49

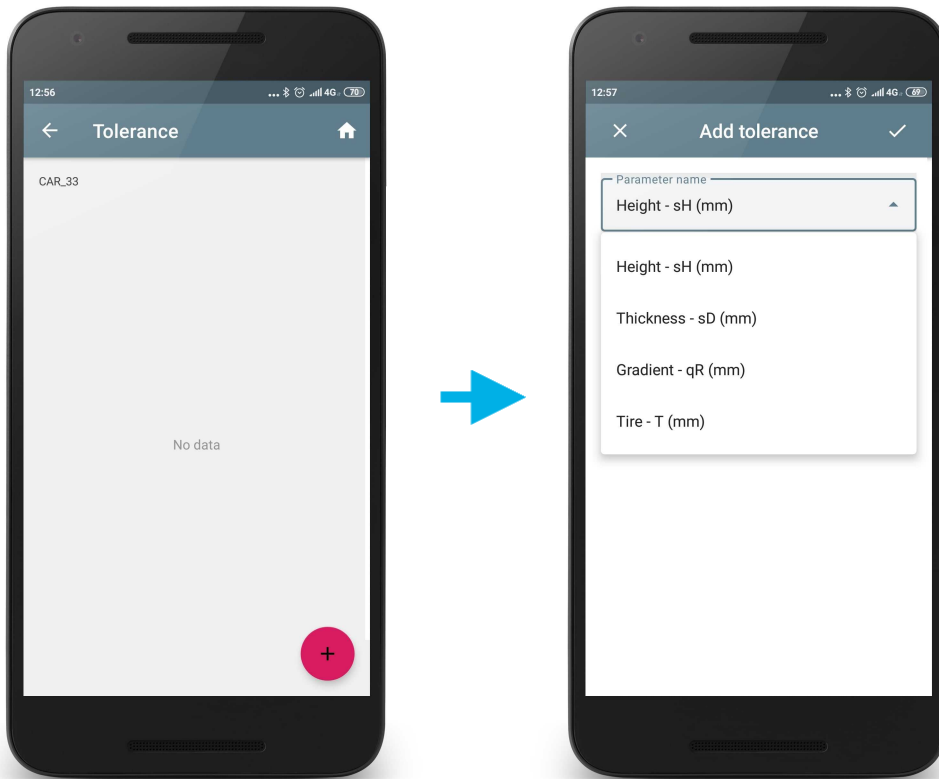

After selecting a parameter, the limit values must be entered.

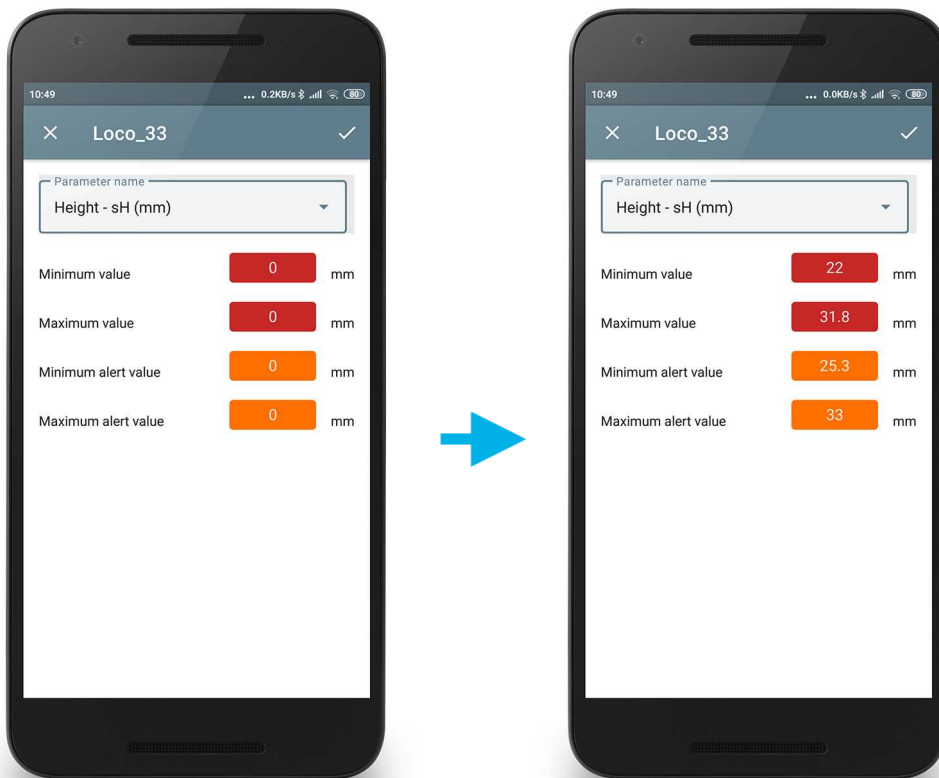

To edit the tolerance, you can enter the desired value using the keyboard, or tap on the field and, holding your finger, select the desired value.

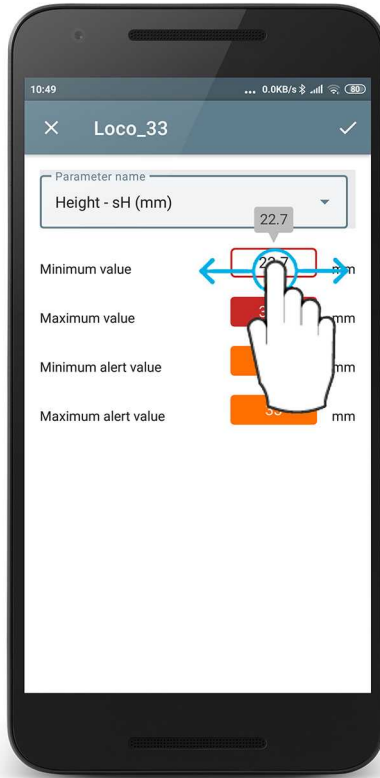

To save the tolerances, tap . The added tolerances for the selected parameter will be displayed in the list.

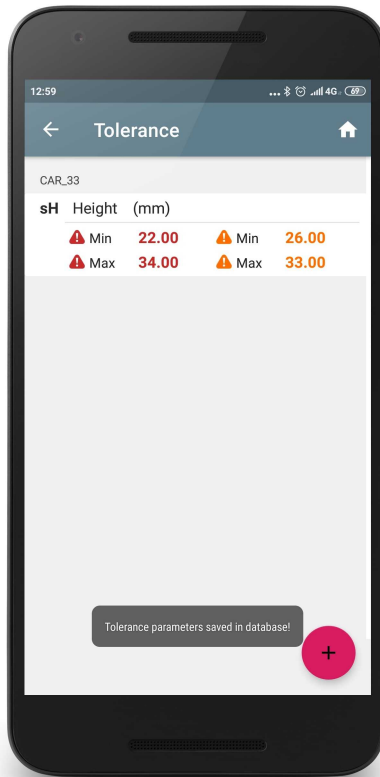

14.4. Wheelset type

If different types of wheels must be measured, it is possible to set a specific scheme, reference profile and parameters for each type.

For instance, there are three types of wheels: WheelType1, WheelType2, WheelType3. Each time you switch to a new type, you can change the parameters, scheme and reference, or you can define these values for each type of wheel and, in the future, select only the required type.

An example:

WheelType1: Reference 1, Scheme 1, Parameters 1;

WheelType2: Reference 2, Scheme 2, Parameters 2;

WheelType3: Reference 3, Scheme 3, Parameters 3;

14.4.1. Selecting and deleting the wheelset type

To select a type as the main one, you need to swipe left from the right edge and tap **Select**. The selected type will be marked with ✓.

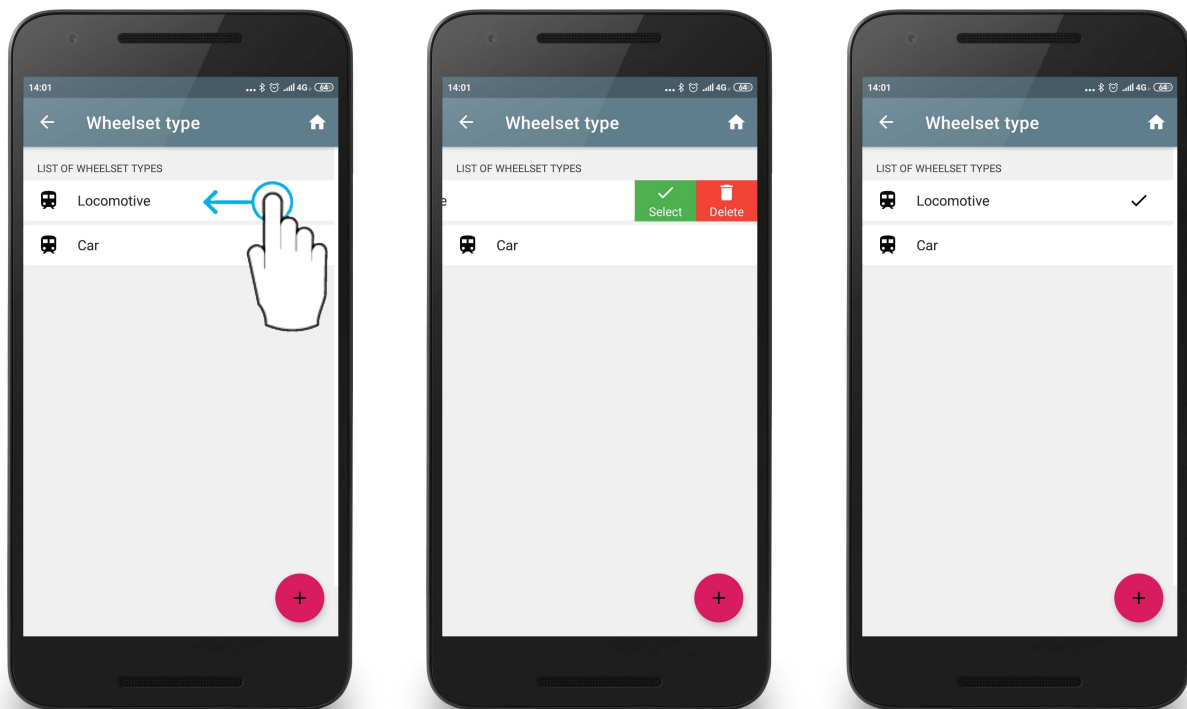

To delete a type, you need to swipe left from the right edge and tap **Delete**, or tap and hold the item with the type name (the procedure is the same as for the references - see par. [Selecting and deleting the reference profile](#)).

14.4.2. Adding the wheelset type

The app comes with preset measurement parameters.

To add a new type of wheel, tap  and enter the name.

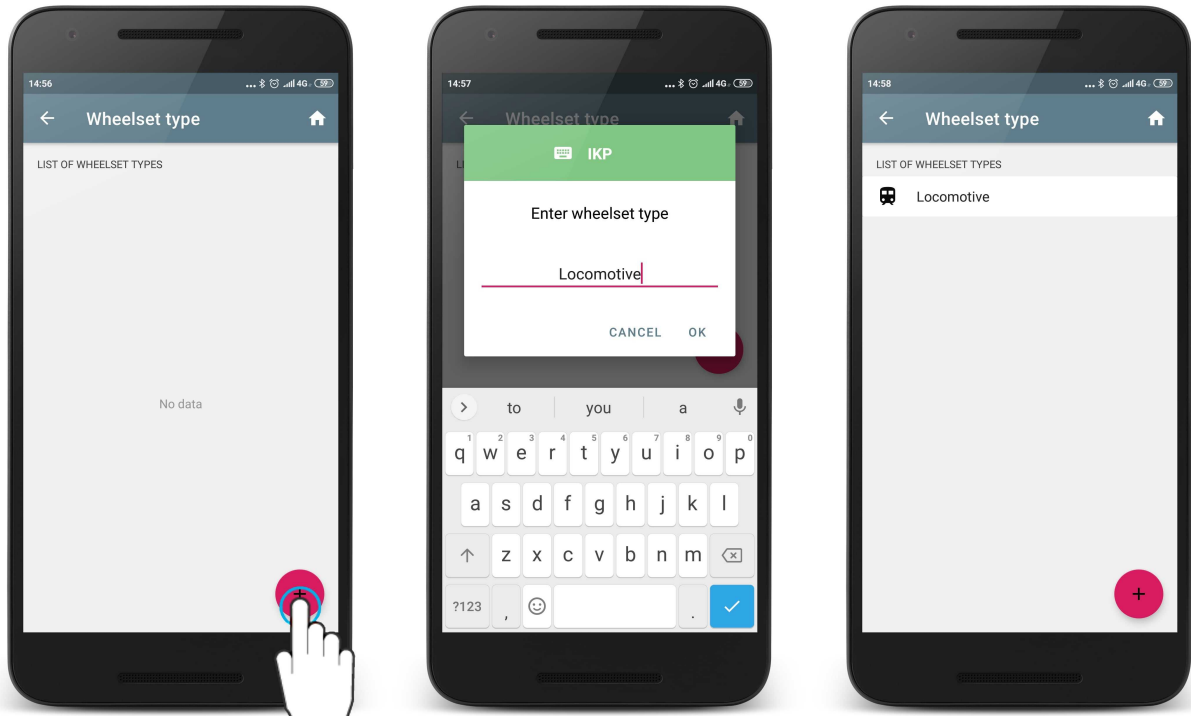

After adding a new type of wheelset, all settings contain standard preset values. To set specific values, you need to edit the created type of wheelset, see par. [Editing the wheelset type](#).

14.4.3. Editing the wheelset type

To edit the wheelset type, tap on the type name.

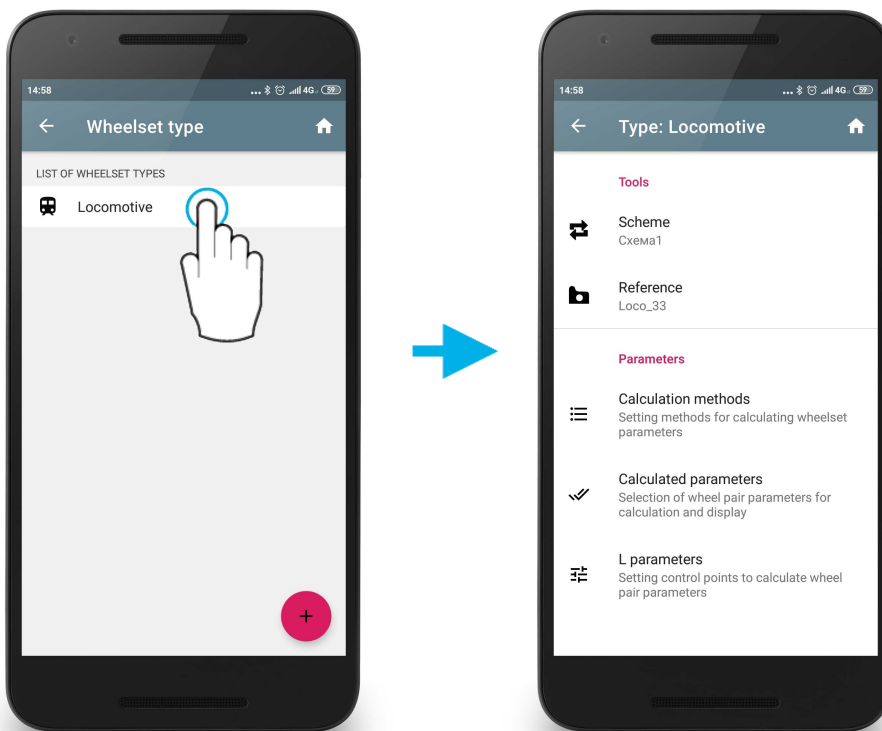

To set the values:

- Select the **Scheme**.
- Select the **Reference**.
- Set the **Calculation methods** (see par. [Calculation methods](#)).
- Set the **Calculated parameters** (see par. [Calculated parameters](#)).
- Set the **L parameters** (see par. [L parameters](#)).

15. Software update

The software version is shown in the **About** window. To open the **About** window, tap  or swipe right from the left edge and select **About**.

53

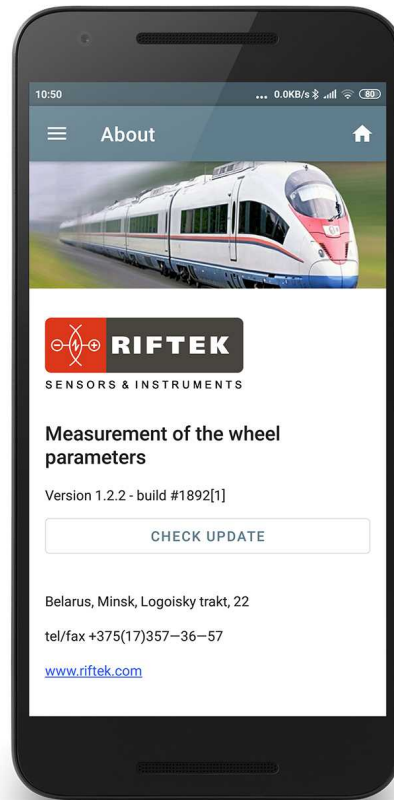

To check if you have the latest version, tap the **CHECK UPDATE** button. If you have the latest version installed, the app will display a corresponding message.

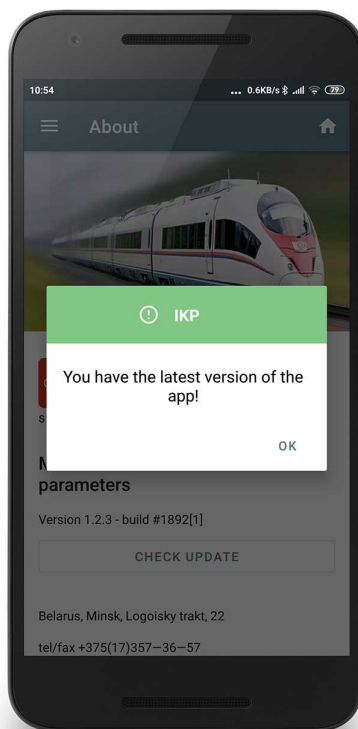

If you do not have the latest version installed, you will be prompted to update the application. Tap **OK** to update. The new version of the application will be downloaded and installed automatically.

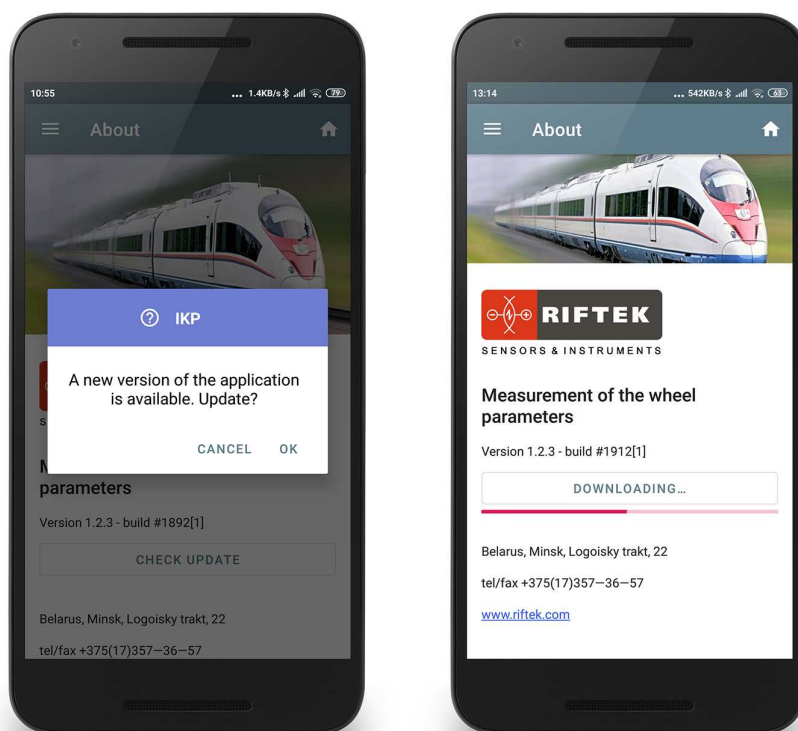

The latest version of the software can be downloaded at:
<https://riftek.com/upload/medialibrary/a75/ikp.zip>

The update procedure is the same as when installing the application.

16. Measurement

There are two measurement types:

1. Rapid measurement (see par. [Rapid measurement](#)).
2. Measurement by scheme (see par. [Measurement by scheme](#)).

How to select the measurement type – see par. [Setting the measurement type](#) or par. [Quick setup](#).

16.1. Quick setup

The main window contains tools that allow the user to quickly configure parameters.



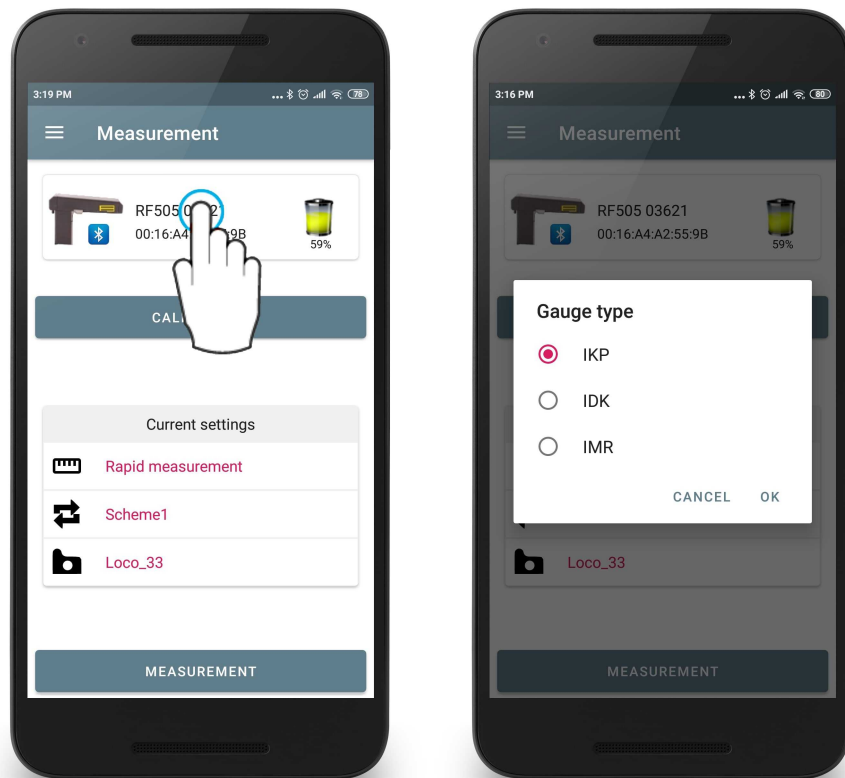

Quick setup is not active if a password for changing parameters is set.

- To quickly select the type of measuring device, tap on the name of the current device and make a selection.

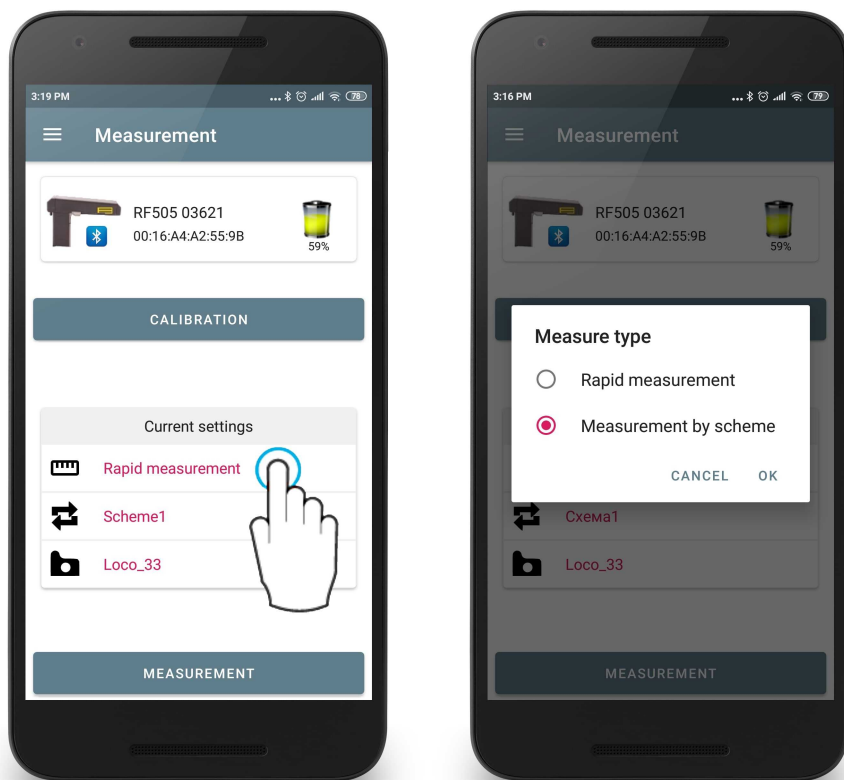

- To quickly select the measurement type, tap on the current measurement type  and make a selection.



- To quickly select the measurement scheme (used when measuring according to the scheme, see par. [Measurement by scheme](#)), tap on the current measurement scheme  and make a selection.

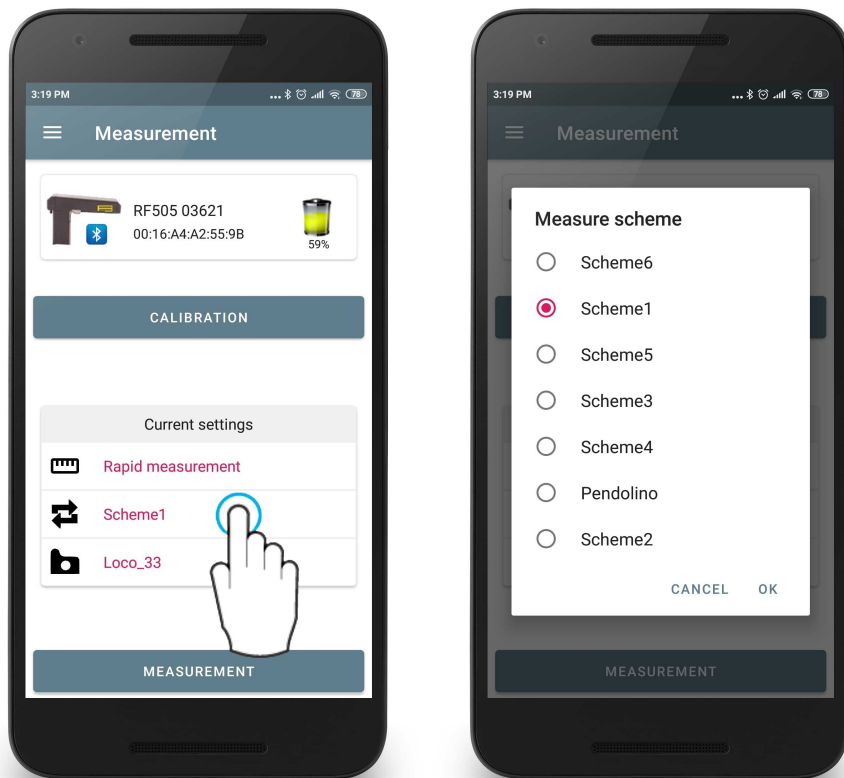

- To quickly select the reference, tap on the current reference  and make a selection.

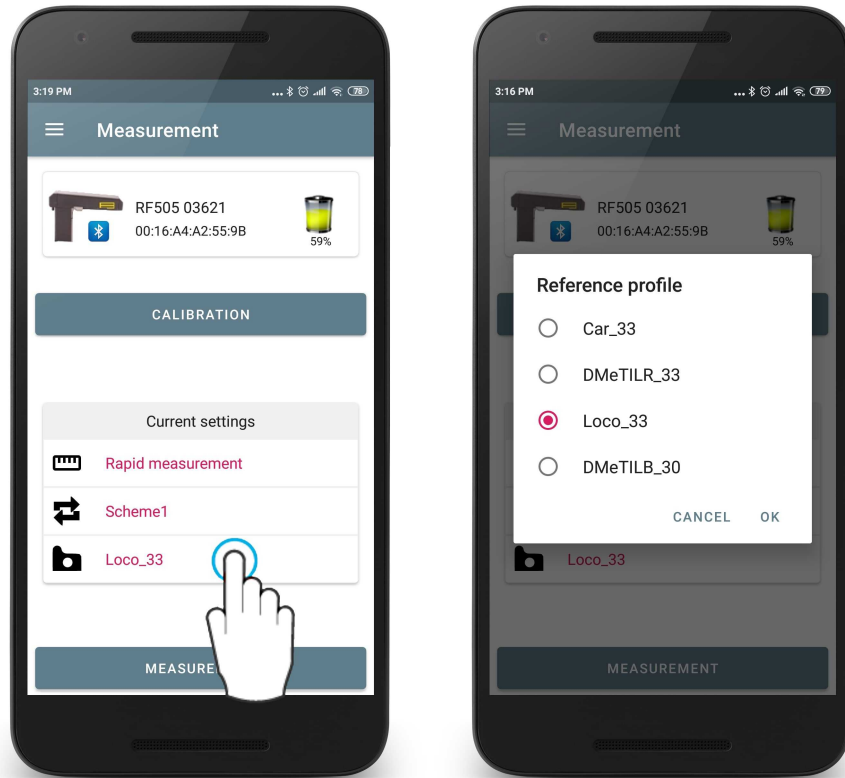

16.2. IKP-5

To synchronize with the profilometer, you need to select **IKP** as the gauge type. Selecting the type of measuring gauge – see par. [Adding and selecting the measurement device](#) or par. [Quick setup](#).

16.2.1. Turning on the gauge

- Before first use, charge the laser module and PDA batteries by connecting them to the charger.
- Turn on the laser module by pressing and holding the power button for a few seconds. When turning on the laser module, the red LED flashes.
- After turning on the laser module, the wireless connection between the module and PDA will be automatically established (during this time, the blue LED is on). Once the connection is established, the blue LED turns off.
- The main program window will be updated:

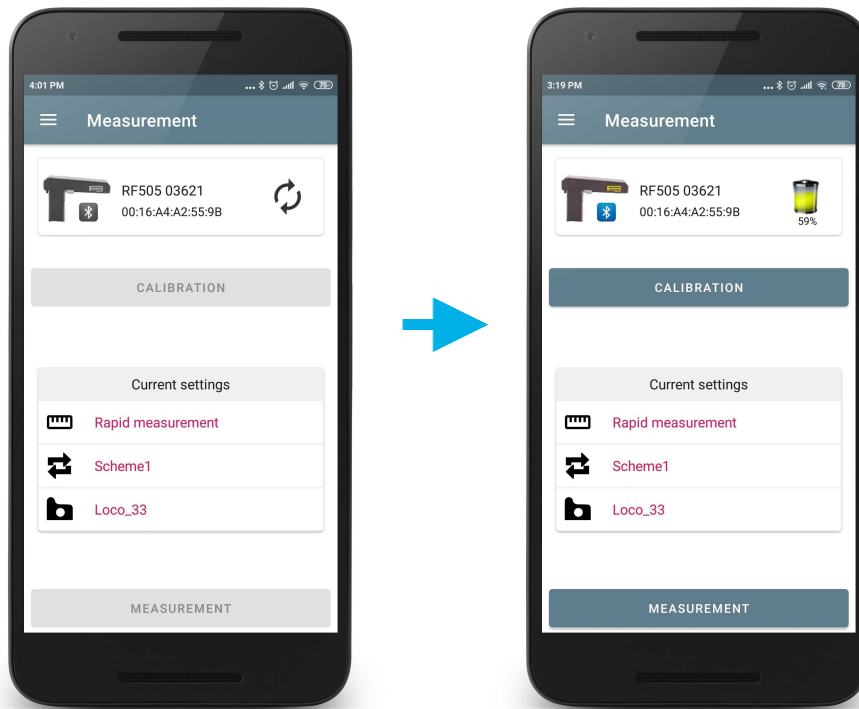

All buttons and indicators become active.

16.2.2. Installing the gauge on the wheel

Attention!
 Before installing the laser module on the wheel, you need to remove any dirt from the areas where the laser scanning module will be in contact with the wheel surface.
 When installing the laser module on the wheel, do not allow strong impacts of its supports against the wheel, because this can lead to incorrect operation of the profilometer.

It is necessary to periodically inspect the output window and base supports of the laser module and clean them of dirt.
 Do not clean glass with abrasive materials or aggressive cleaning agents.

To make measurements, follow these steps:

- Install the laser module on the calibration block or wheel - place the support of the laser module on the wheel flange and press the magnetic support against the inner edge of the wheel.
- For the rim measurement, extract the rim measurement rod and hitch it up to the rim.



- Make sure that the module is mounted correctly without any misalignment and gaps.

16.2.3. Rapid measurement

This measurement type is used to quickly measure parameters or to save a single measurement to the database with the possibility of setting wheel identification parameters.

Procedure:

- Tap the **MEASUREMENT** button. The application will ask for the calibration parameters of the laser module and, in case of successful reading, the **Measurement** window will appear.

59

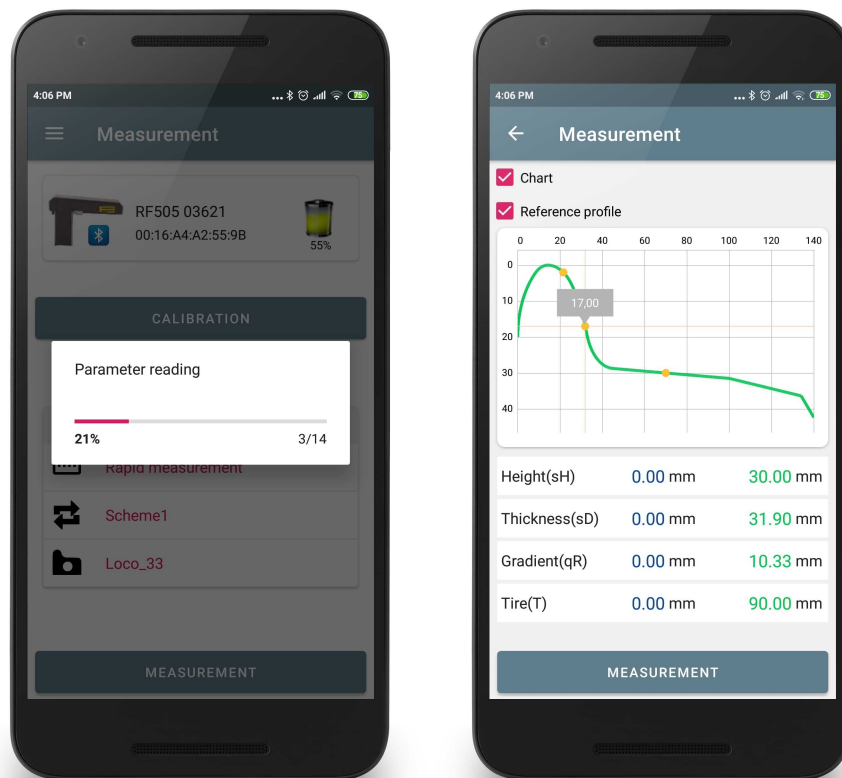

- When you tap the **Measurement** button, the laser module will scan the wheel surface. The scanning time is about 1-2 seconds, during which the red LED is on.
- After completing the scanning process, the application will display the measured parameters.

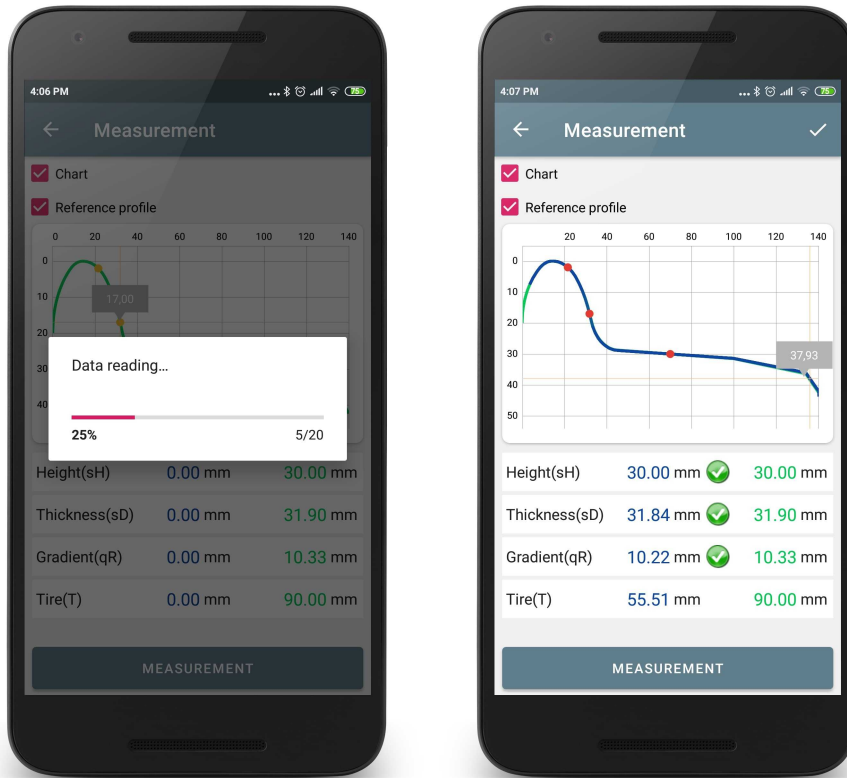

When the value is outside the specified tolerance, it is highlighted in red (orange):

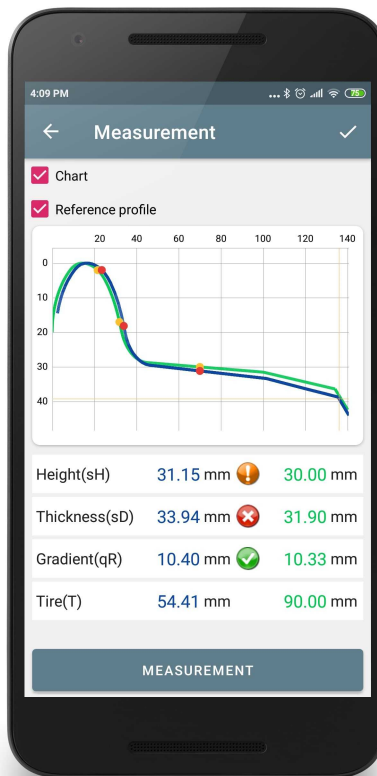

- If necessary, tap the **Measurement** button to scan the wheel surface again. It is possible to display only the parameters of the measured profile. To do this, clear the **Reference profile** checkbox.

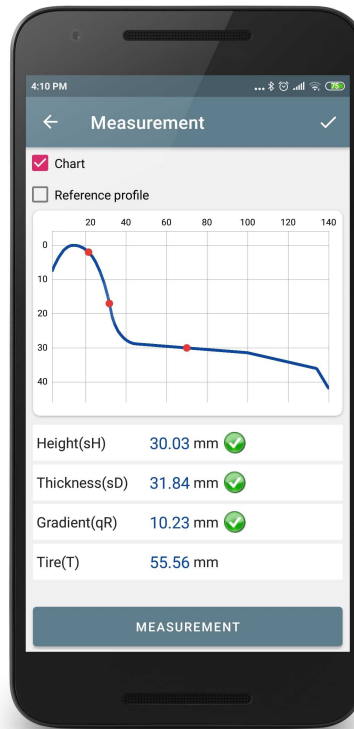

- When scanning the calibration block or the reference wheel, the scan results must differ from the nominal values by no more than 0.1 mm. In this case, the device is ready for operation, otherwise it is necessary to calibrate the device in accordance with the User Manual.
- If the wheel was scanned once, tap to save it and enter the wheel identification parameters.

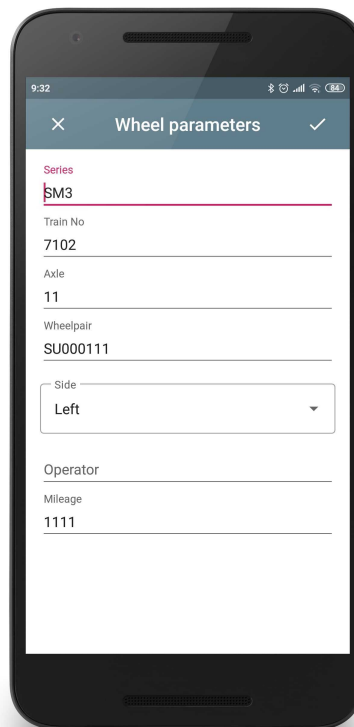

The measurement will be saved to the database (see par. [Viewing measurement results](#)).

16.2.4. Measurement by scheme

This measurement type makes it possible to use all features of the profilometer, such as working with the database of measurements.





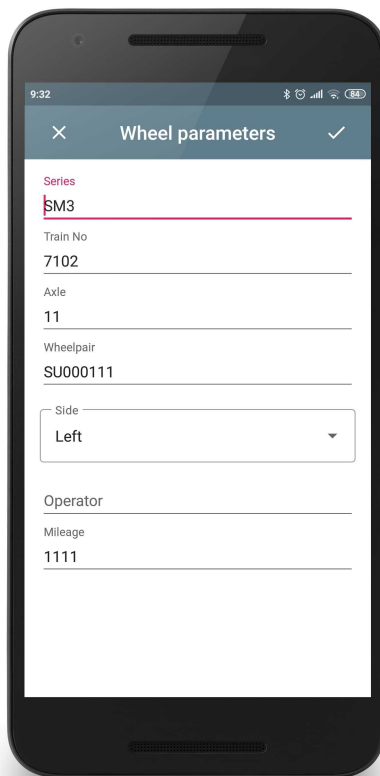



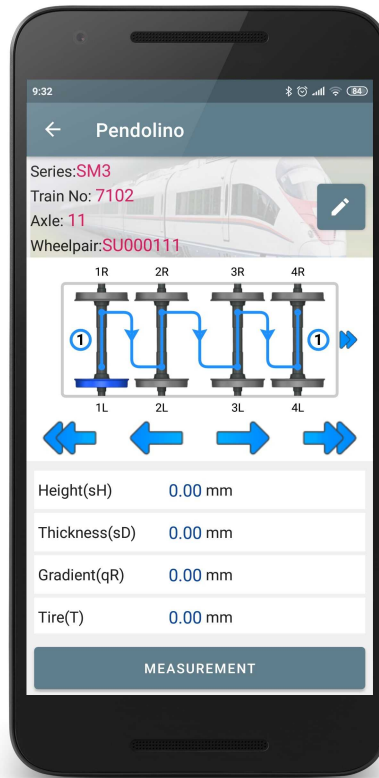

Procedure:

- Tap the **Measurement** button. The application will request the calibration parameters of the laser module and, in case of successful reading, the **Wheel parameters** window will appear. The values are displayed in accordance with the selected measurement scheme. If necessary, the user can edit the parameters.



- To save the parameters, tap . The application will display the selected measurement scheme, as well as the values of the wheel parameters that are selected for the calculation (see par. [Calculated parameters](#)).



	Editing the entered parameters of the wheelset.
	Moving to the previous/next wheel.
	Moving to the previous/next car.
	The unmeasured wheel.
	The wheel to be measured.
	The measured wheel (within tolerance).
	The measured wheel that will be measured again.
	The measured wheel, the parameters of which are close to the critical values.
	The measured wheel, the parameters of which are outside the critical values.
	Ordinal number of the car (displayed if there are several cars in the scheme)

- To measure the wheel suggested by the application (highlighted in green), tap the **MEASUREMENT** button. The laser module will scan the wheel surface.
- After scanning, the measured values of the wheel geometric parameters are displayed on the screen. If a parameter is beyond the specified tolerance, its value is highlighted in orange or red:



It is possible to display only the parameters of the measured profile. To do this, clear the **Reference profile** checkbox.

- To repeat the measurement, tap the **MEASUREMENT** button.
- When a satisfactory result is obtained, tap to save the data.
- The application will offer to measure the next wheel in accordance with the measurement scheme.

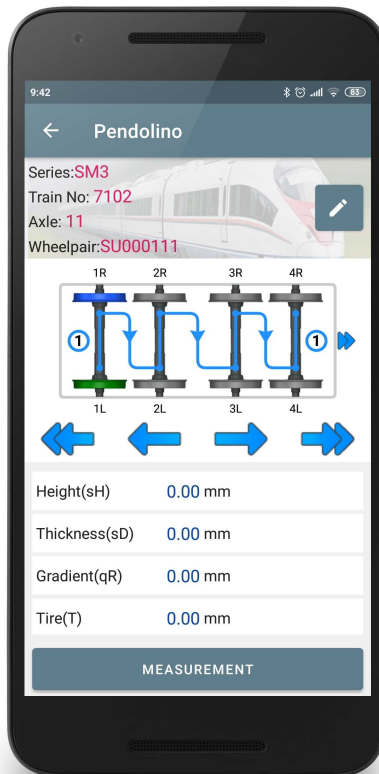

- Use the navigation arrows to view the results of the previous measurement. If you select the measured wheel, the saved wheel parameters will be displayed.

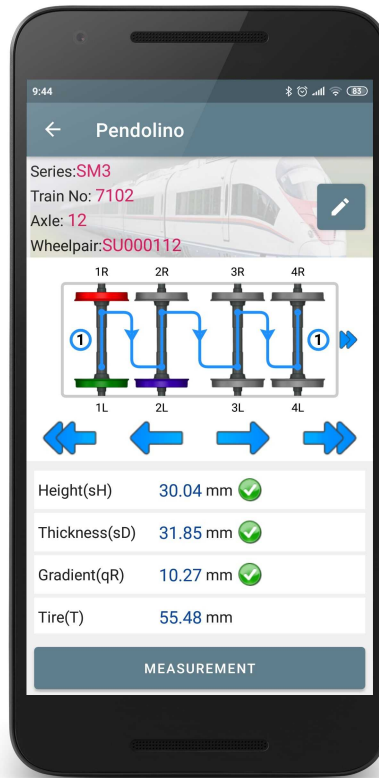

- When you select the measured wheel, the application will warn you that the measurement with such parameters has already been saved in the database and will offer to save the new measurement.

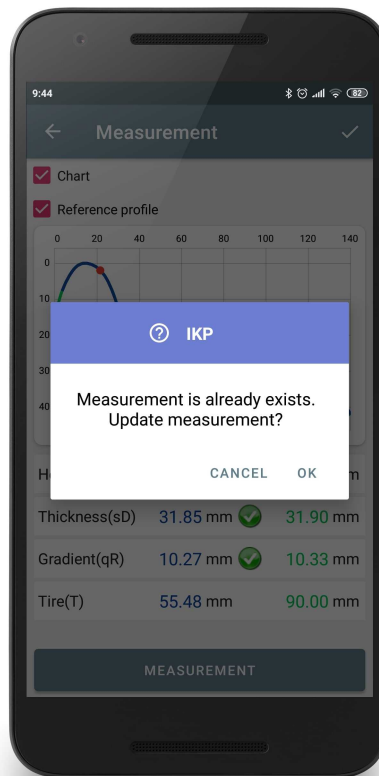

All saved measurements will be saved to the database (see par. [Viewing measurement results](#)).

16.3. IDK-BT

To synchronize with the wheel diameter measuring gauge, you need to select **IDK** as the gauge type. Selecting the type of measuring gauge – see par. [Adding and selecting the measurement device](#) or par. [Quick setup](#).

16.3.1. Turning on the gauge

- Before using for the first time, charge the batteries of the IDK by connecting them to the charger.
- Press the **Red** button to turn on the gauge.



The display shows “ErrP” message if the battery voltage is below the control level. In this case, short-term operation is possible after pressing any button.

- After turning on the gauge, a wireless connection is automatically being established between the module and the mobile device (the blue LED is on). Once the connection is established, the LED turns off.
- The main window will be updated:

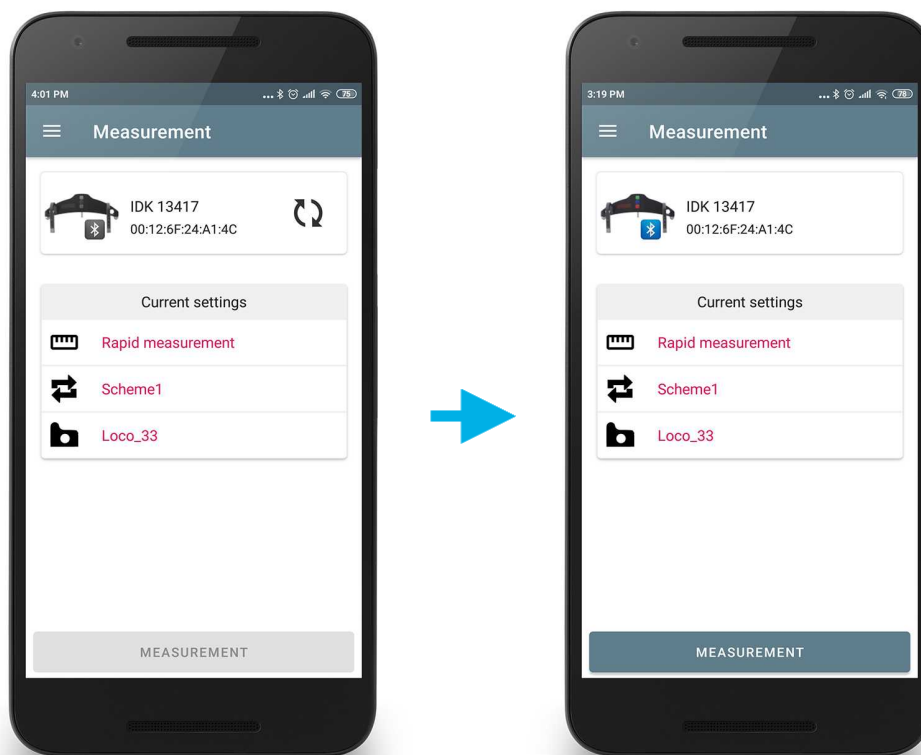

The **MEASUREMENT** button and the Bluetooth connection indicator become active.

16.3.2. Installing the gauge on the wheel

To make a measurement, do the following:

- Place the gauge onto the wheel.
- Make sure the ball supports and the measuring tip of the gauge are tight against the roll surface and side supports are adjacent to the edge of the wheel.

16.3.3. Rapid measurement

This measurement type is used to quickly measure the diameter or to save a single measurement to the database with the possibility of setting wheel identification parameters.

Procedure:

- Tap the **MEASUREMENT** button. The application will ask for the calibration parameters of the IDK and, in case of successful reading, the **Measurement** window will appear.

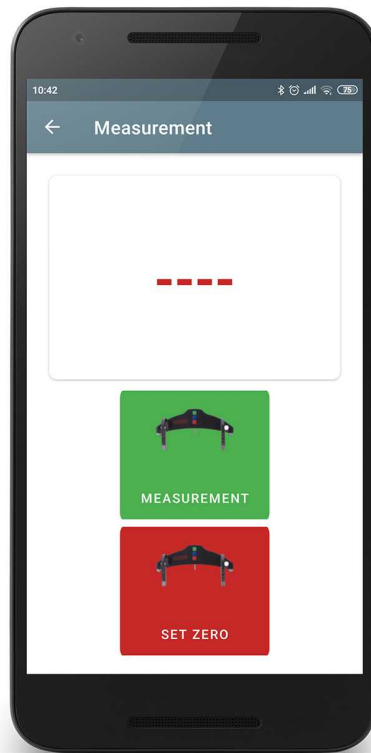

- Measure the diameter.



- Reset the averaging result (the display shows "-----").

- Press the **Green** button. After a second, the wheel diameter value will appear on the display.
- When the diameter value exceeds the specified tolerance, its value is highlighted in red:

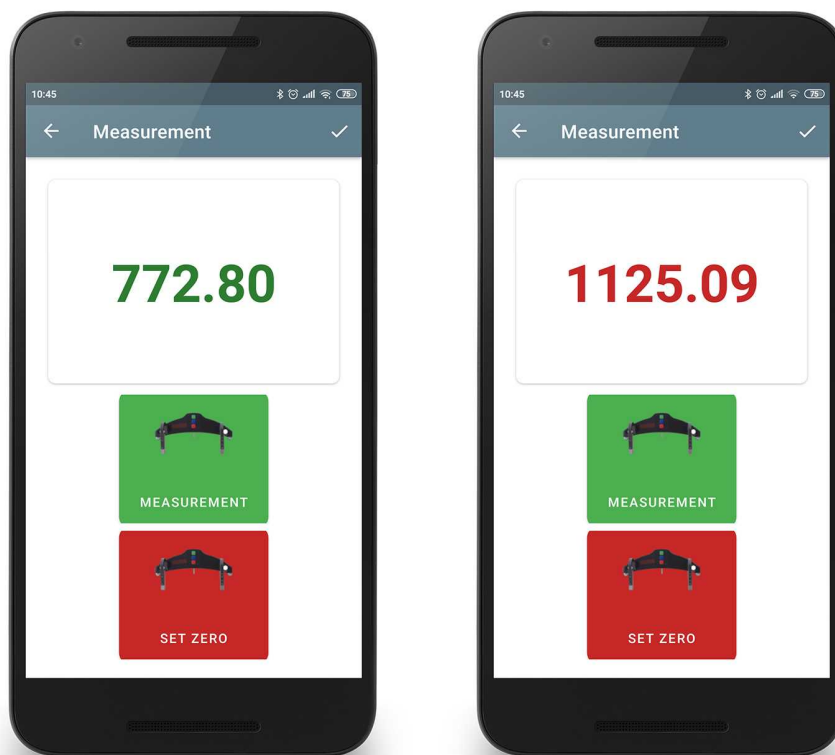

To continue measurements with averaging:

- Press the **Green** button.
- The IDK display will show the value of the “n x” counter, where x is the number of averaged measurements.
- After a second, the average value of the wheel diameter will be displayed.
- Install the gauge to a new position and repeat the measurements. The total number of measurements averaged in this way can reach 9999.
- Press the **Red** button to reset the averaging result.
- To save the measurement, click and enter the wheel identification parameters.

The measurement will be saved to the database (see [Viewing measurement results](#)).

16.3.4. Measurement by scheme

This measurement type makes it possible to use all features of the gauge, such as working with the database of measurements.

Procedure:

- Tap the **Measurement** button. The application will request the parameters of the IDK and, in case of successful reading, the **Wheel parameters** window will appear. The values are displayed in accordance with the selected measurement scheme. If necessary, the user can edit the parameters.

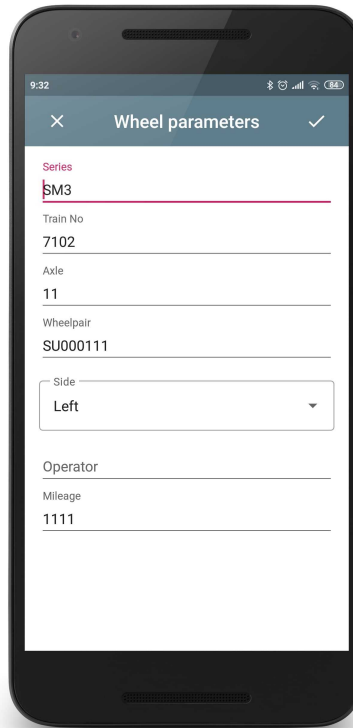

- To save the parameters, tap . The application will display the selected measurement scheme and diameter values.

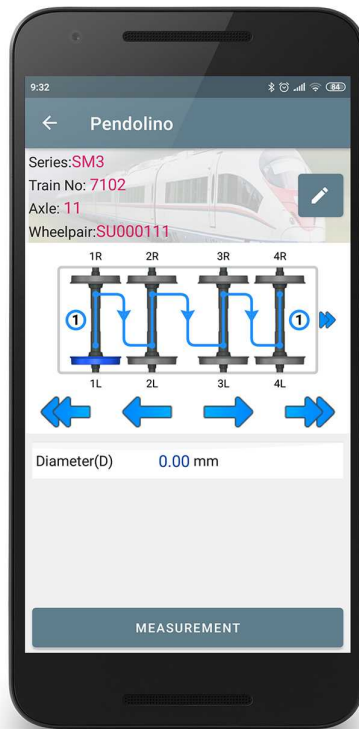

Buttons assignment - see [Measurement by scheme](#).

- To measure the wheel suggested by the application (highlighted in green), tap the **MEASUREMENT** button. The application will display the **Measurement** window and the IDK will measure the diameter. The measured wheel diameter will be displayed.

When the diameter value exceeds the specified tolerance, the value is highlighted in red:

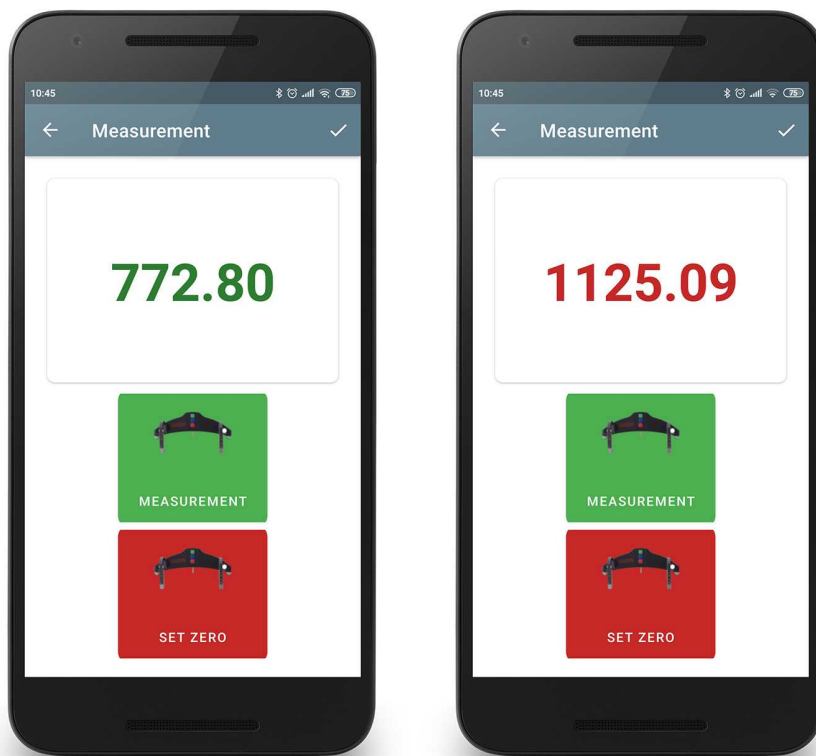

70

- To repeat the measurement, tap the **MEASUREMENT** button.
- When a satisfactory result is obtained, tap to save the data.
- The application will offer to measure the next wheel in accordance with the measurement scheme.

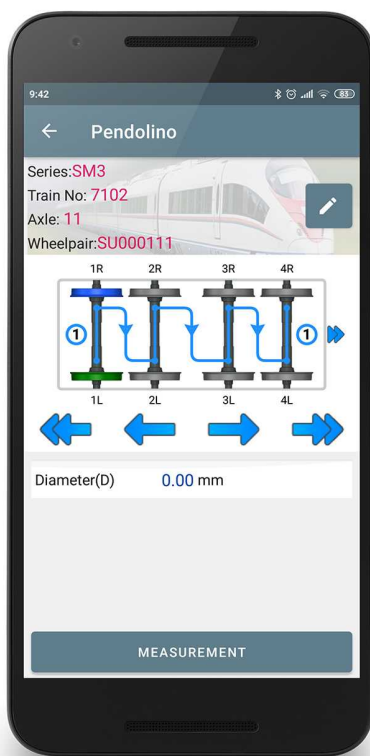

- Use the navigation arrows to view the results of the previous measurement. If you select the measured wheel, the saved wheel diameter will be displayed.

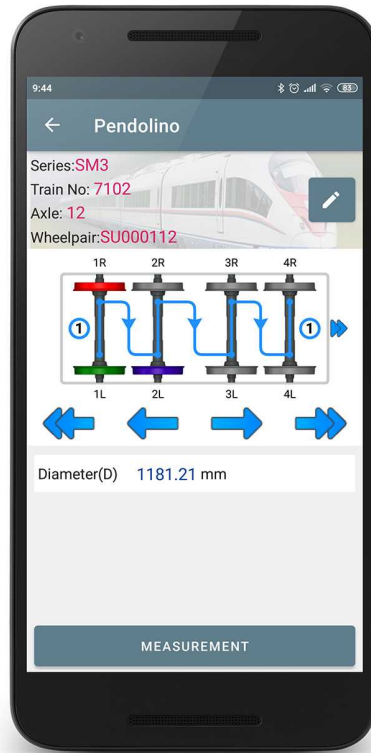

- When you select the measured wheel, the application will warn you that the measurement with such parameters has already been saved in the database and will offer to save the new measurement instead of the existing one.

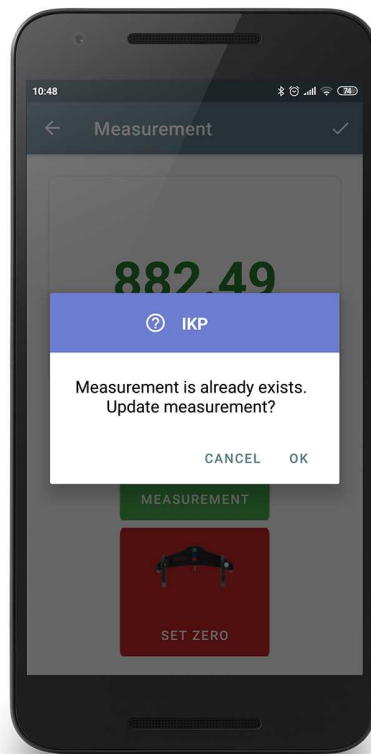

All saved measurements will be saved to the database (see par. [Viewing measurement results](#)).

16.4. IMR

To synchronize with the back-to-back distance measuring gauge, you need to select **IMR** as the gauge type. Selecting the type of measuring gauge – see par. [Adding and selecting the measurement device](#) or par. [Quick setup](#).

16.4.1. Turning on the gauge

- Before using for the first time, charge the batteries of the IMR by connecting them to the charger.
- Press the **Red** button to turn on the gauge.



The display shows “ErrP” message if the battery voltage is below the control level. In this case, short-term operation is possible after pressing any button.

- After turning on the gauge, a wireless connection is automatically being established between the module and the mobile device (the blue LED is on). Once the connection is established, the LED turns off.
- The main window will be updated:

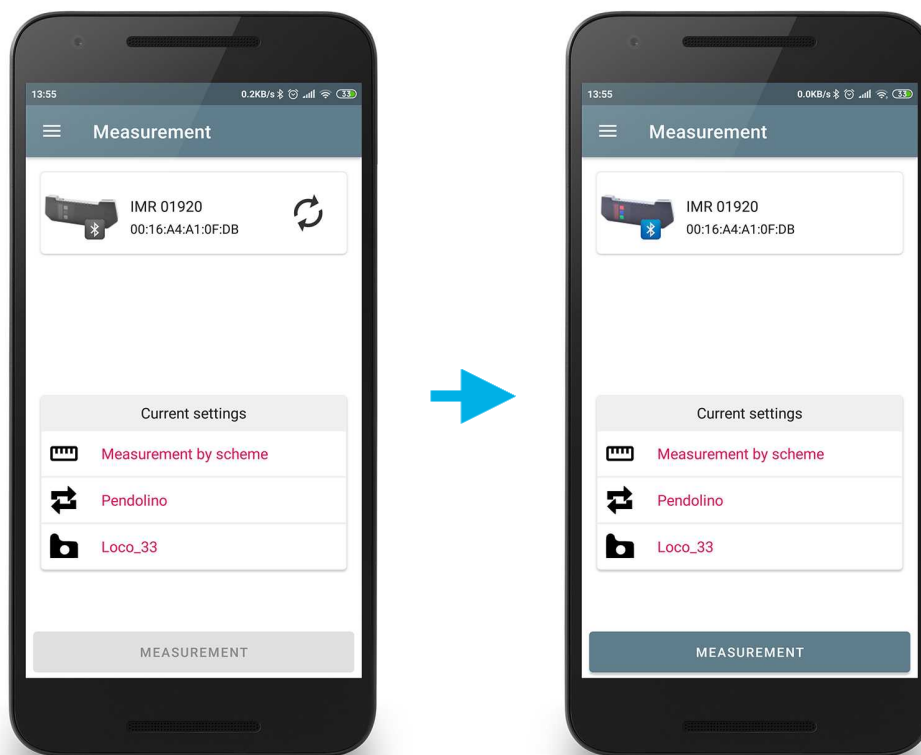

The **MEASUREMENT** button and the Bluetooth connection indicator become active.

16.4.2. Installing the gauge on the wheel

To make a measurement, do the following:

- Install the gauge on the inner surface of the wheel.
- Make sure the magnetic base is firmly attached to the surface.

To avoid hitting the gauge against the wheel, follow the instructions below:

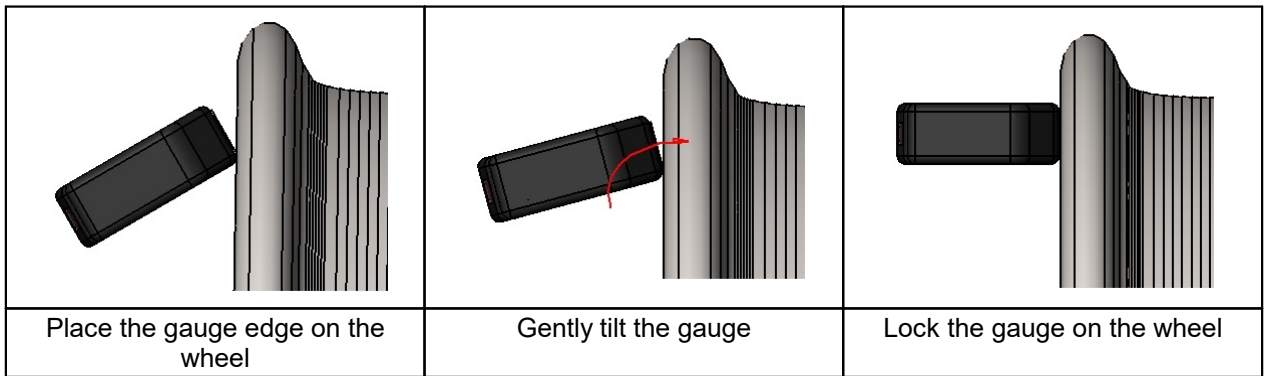

16.4.3. Rapid measurement

This measurement type is used to quickly measure the back-to-back distance or to save a single measurement to the database with the possibility of setting wheel identification parameters.

Procedure:

- Tap the **MEASUREMENT** button. The application will ask for IMR parameters and, in case of successful reading, the **Measurement** window will appear.

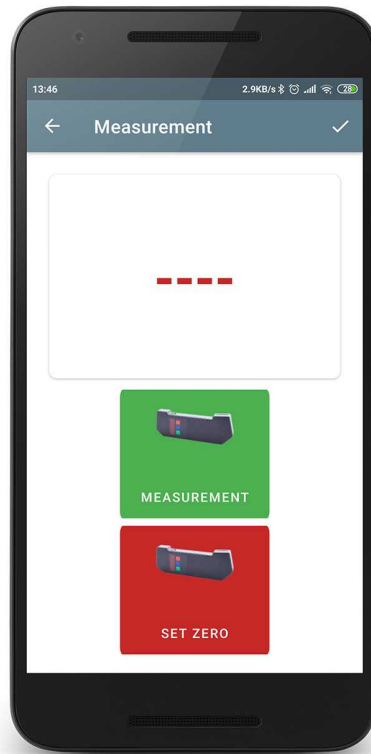

- Measure the back-to-back distance.



- Reset the averaging result (the display shows "-----").

- Press the **Green** button. After a second, the measured value will appear on the display.
- When the value exceeds the specified tolerance, it is highlighted in red:

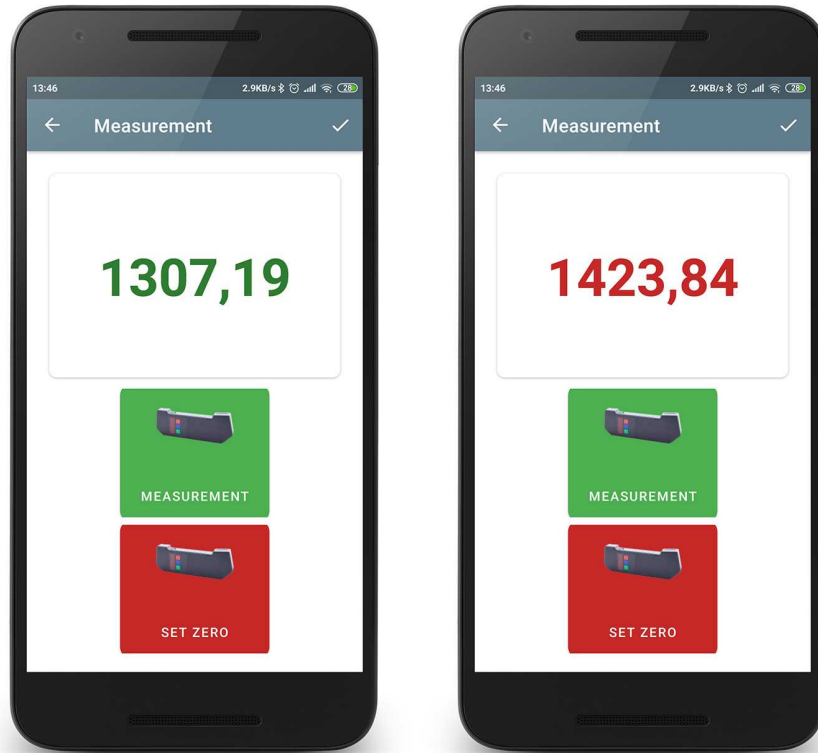

To continue measurements with averaging:

- Press the **Green** button.
- The display will show the value of the “n x” counter, where x is the number of averaged measurements.
- After a second, the average value of the back-to-back will be displayed.
- Install the gauge to a new position and repeat the measurements. The total number of measurements averaged in this way can reach 9999.
- Press the **Red** button to reset the averaging result.
- To save the measurement, click and enter the wheel identification parameters.

The measurement will be saved to the database (see [Viewing measurement results](#)).

16.4.4. Measurement by scheme

This measurement type makes it possible to use all features of the gauge, such as working with the database of measurements.

Procedure:

- Tap the **Measurement** button. The application will request the parameters of the IMR and, in case of successful reading, the **Wheel parameters** window will appear. The values are displayed in accordance with the selected measurement scheme. If necessary, the user can edit the parameters.

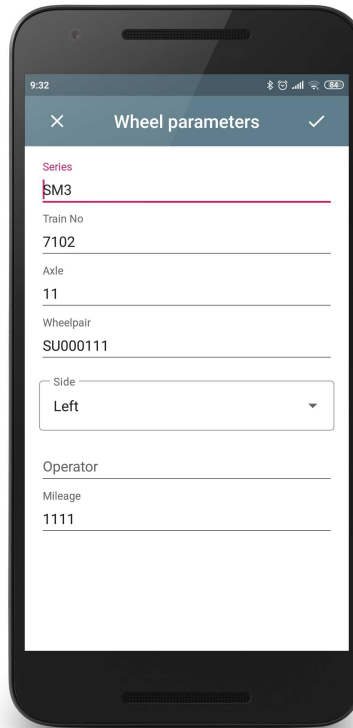

- To save the parameters, tap . The application will display the selected measurement scheme and back-to-back distance values.

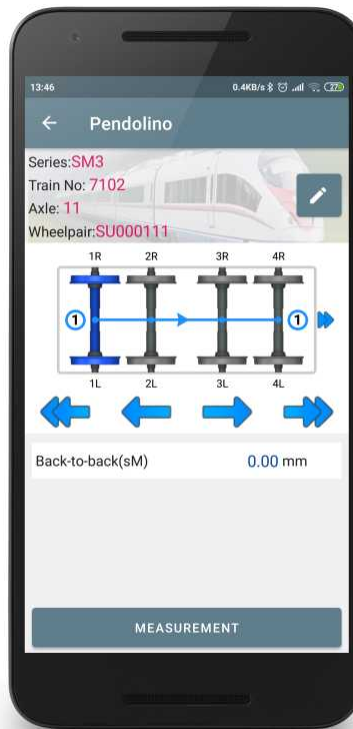

Buttons assignment - see [Measurement by scheme](#).

- To measure the back-to-back distance suggested by the application (highlighted in green), tap the **MEASUREMENT** button. The application will display the **Measurement** window and the IMR will perform the measurement. The measured back-to-back distance will be displayed.

When the back-to-back distance value exceeds the specified tolerance, the value is highlighted in red:

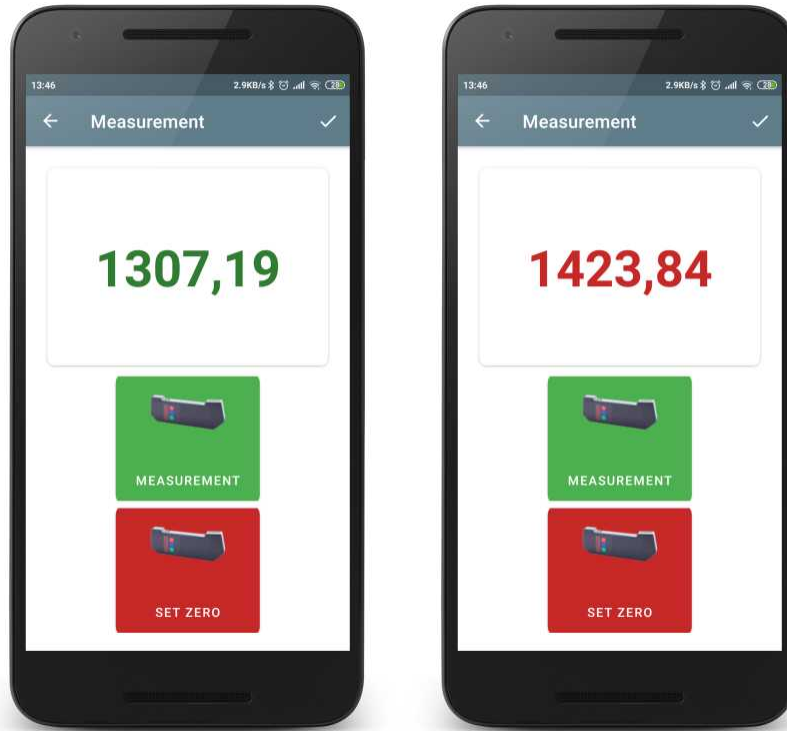

- To repeat the measurement, tap the **MEASUREMENT** button.
- When a satisfactory result is obtained, tap to save the data.
- The application will offer to measure the next wheel in accordance with the measurement scheme.

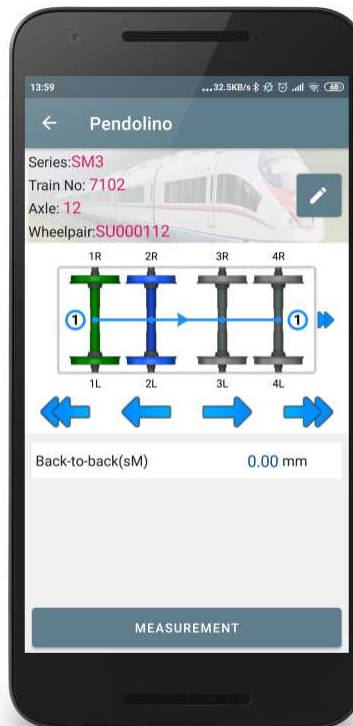

- Use the navigation arrows to view the results of the previous measurement. If you select the measured wheel, the saved back-to-back distance will be displayed.

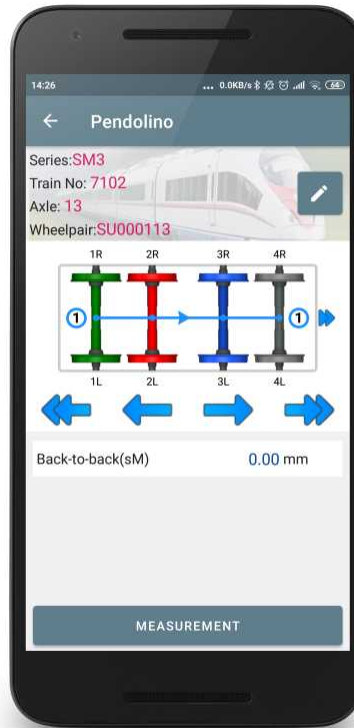

- When you select the measured wheel, the application will warn you that the measurement with such parameters has already been saved in the database and will offer to save the new measurement instead of the existing one.

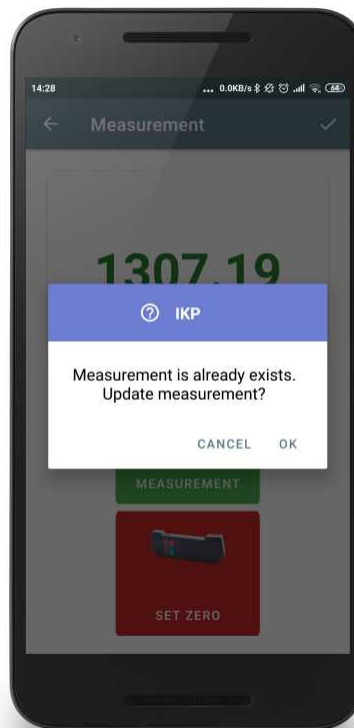

All saved measurements will be saved to the database (see par. [Viewing measurement results](#)).

17. IKP calibration

The profilometer can be supplied complete with the calibration block (RF505.1) designed for periodic testing and calibration of the profilometer.

Instead of the calibration block, you can use a wheel with a known profile saved in the database (see par. [Reference profile](#)).

17.1. Preparing for calibration

- Turn on the laser module.
- Install laser module on the calibration block.
- Wait until the Bluetooth connection is established between the module and PDA - the **Calibration** button will become active.
- Tap the **Calibration** button. The application will request the calibration parameters of the laser module (if the parameters were not received earlier) and, if the parameters were successfully read, the **Calibration** window will appear.

17.2. Calibration procedure

The **Calibration** window contains two tabs: **Measurement** and **Parameters**.

The **Measurement** tab displays the selected reference profile and its parameters, as well as the measured profile and calculated parameters (after measurement).

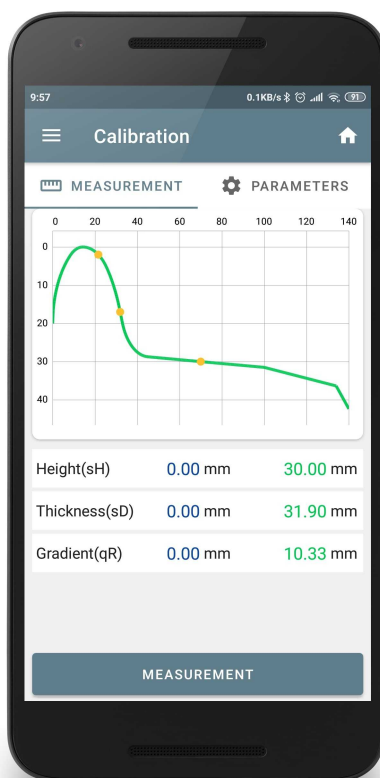

The **Parameters** tab displays the IKP calibration parameters written to the FLASH memory of the device.

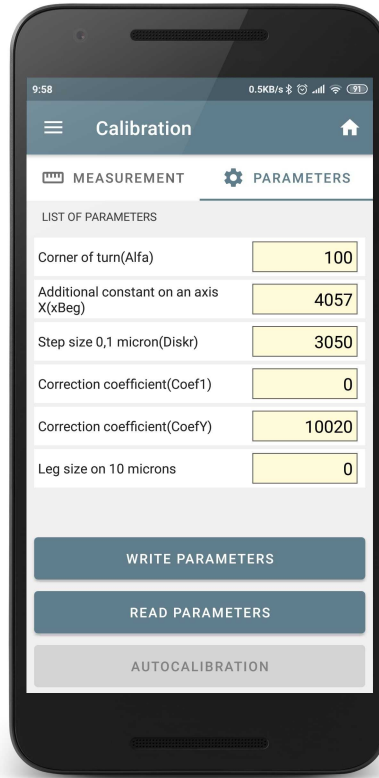

To perform automatic calibration, follow these steps:

- Tap the **MEASUREMENT** button.



- Tap the **AUTOCALIBRATION** button. The calibration parameters will be automatically calculated and the measured profile will be recalculated.



- Tap the **WRITE PARAMETERS** button to save parameters.

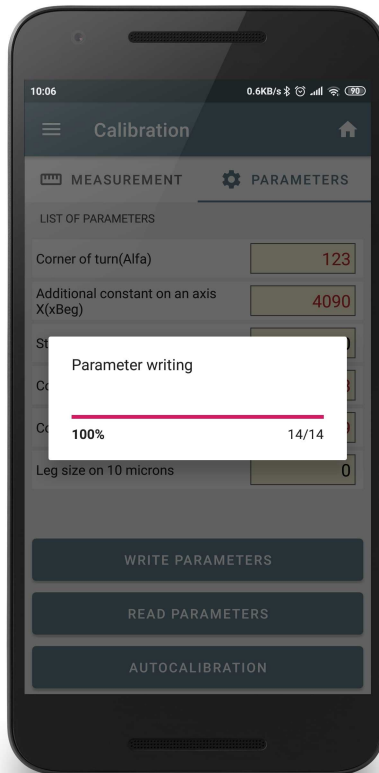

18. Browsing the database

To view the saved data, go to the main menu (tap , or swipe right from the left edge of the screen) and select **Profiles**.

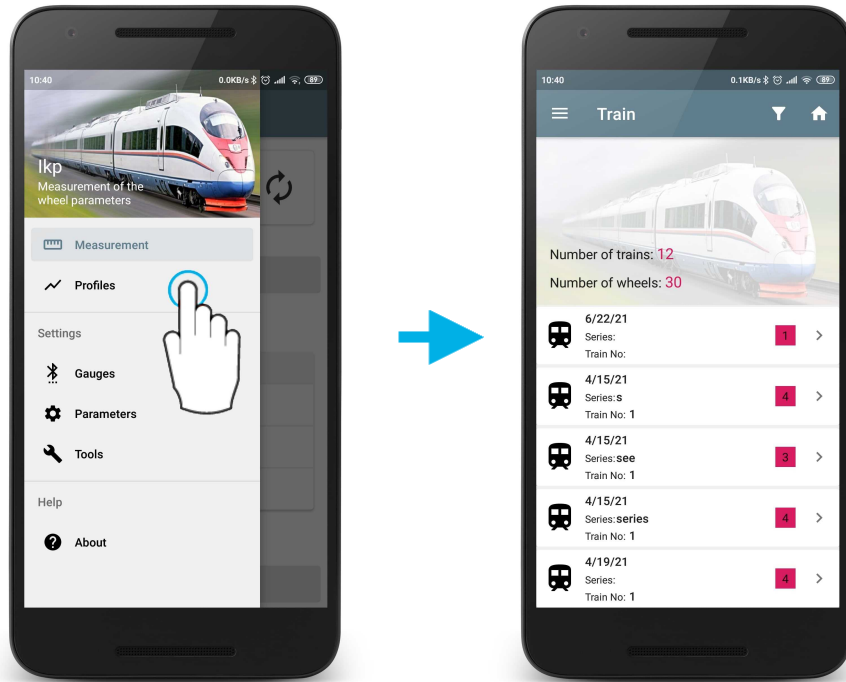

The application will display a list of the measured locomotives/cars, as well as their total number and the number of measured wheels.

18.1. Exporting data

To export several or all locomotives/cars, you need to tap and hold the required locomotive/car. Multiple selection mode will start. Before exporting, you can filter the required data (see par. [Filtering data](#)).

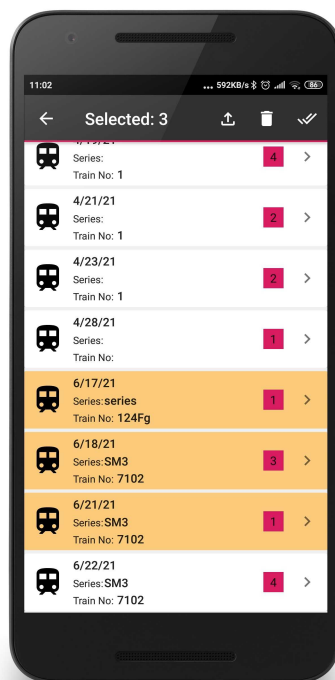

Then select the locomotives/cars that you want to export to a PC and tap .

If several options are selected in the export settings, a menu will appear on the screen with options for exporting data.

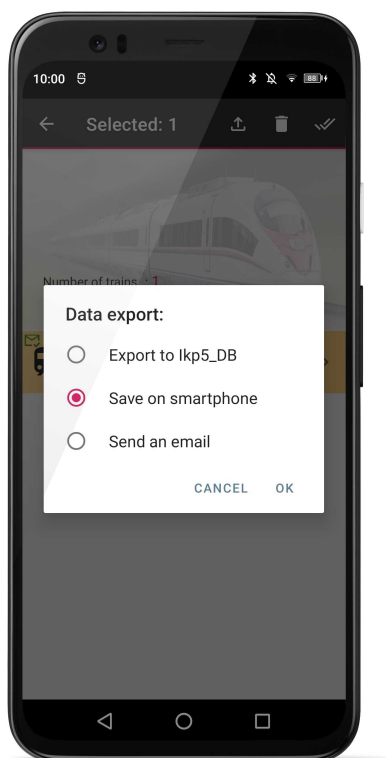

- To export to a PC, select **Export to DB ikp5_BD**

Attention! To successfully export data to a PC, the Ikp5_DB program must be launched, and the correct IP address must be set in the PC server settings (see PC Server Settings)

If unsuccessful, a pop-up message will appear on the screen:

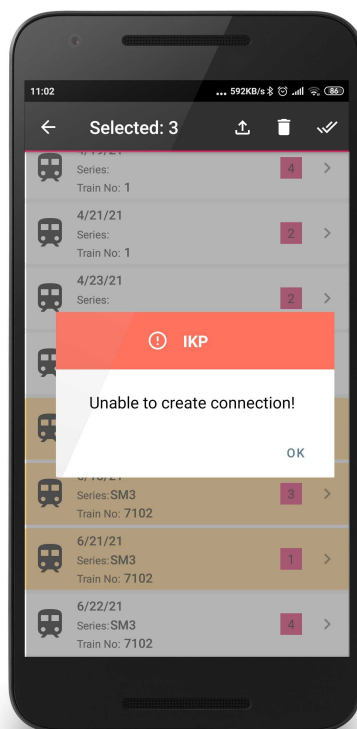

- To save data to your Android device, select **Save to smartphone**.

The data will be saved in the internal memory in the \\Download folder.

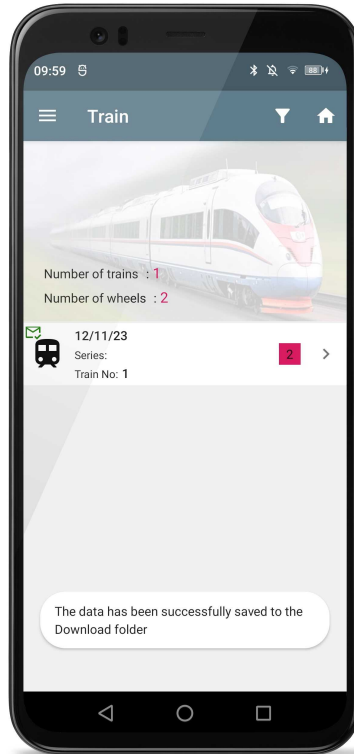

- To send data by email, select **Send email**.
The data will be sent to the email address entered in the settings.

 **Attention!**
To successfully send data, the smartphone must be connected to the Internet.

18.2. Filtering data

To add a filter, tap the **Filter** button (), and then select the fields by which the data will be filtered.

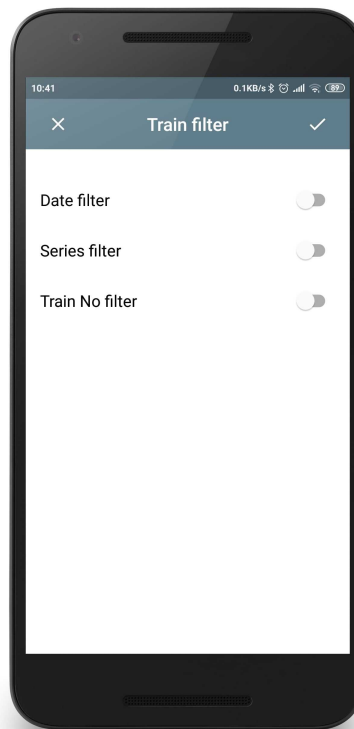

An example of filtering by date:

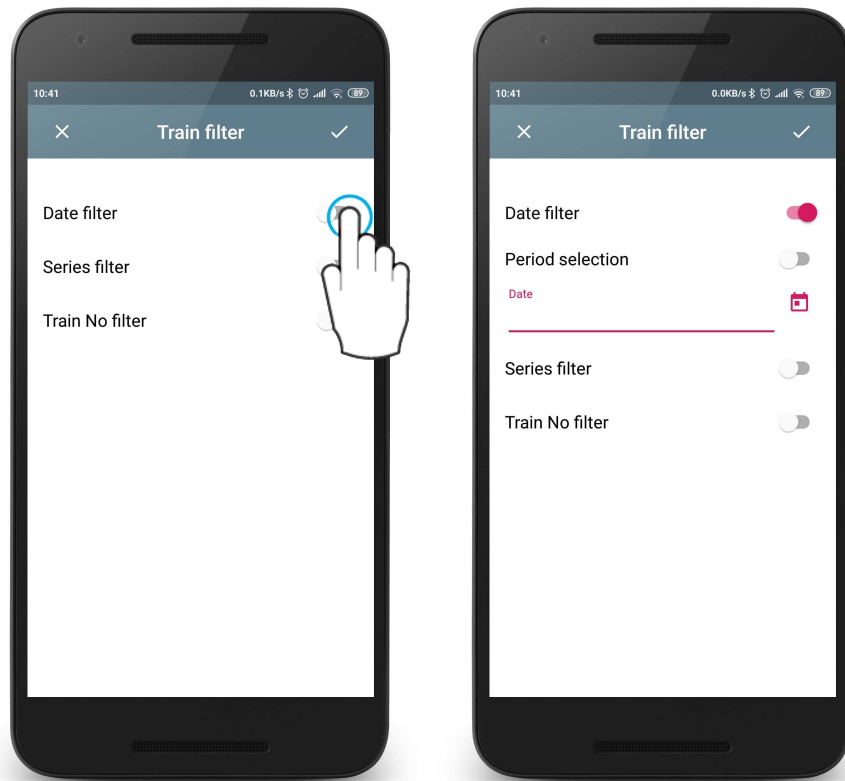

Tap on the date selection icon (📅) and select the date.

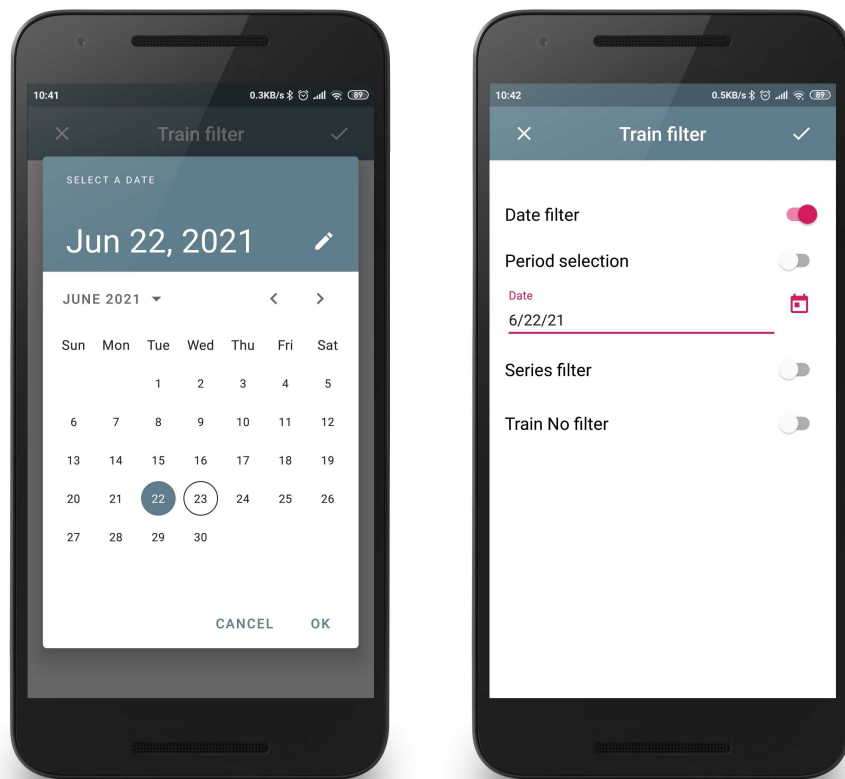

Tap to apply a filter. The app will display only those measurements that match the filter.

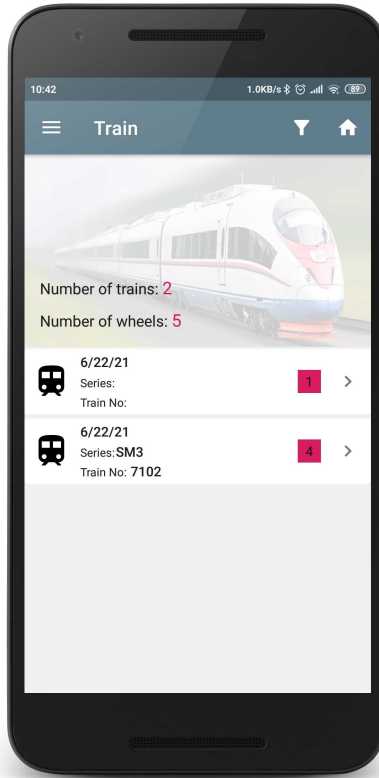

You can also filter the measured data for a specific period of time. To do this, you need to enable the **Period selection** option and select the required period in the calendar.

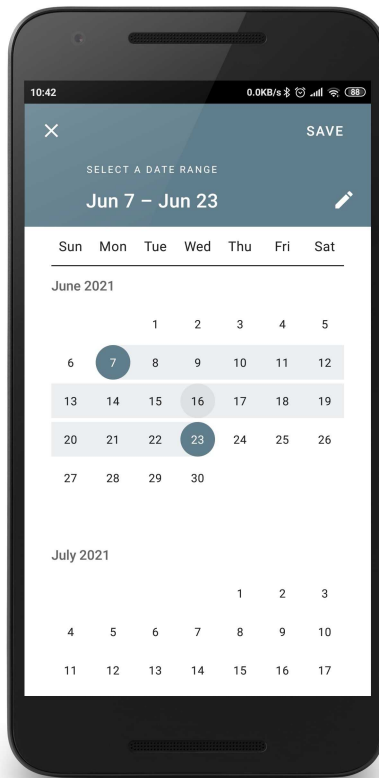

To add a filter by series or locomotive/car number, select the required value from the drop-down list.

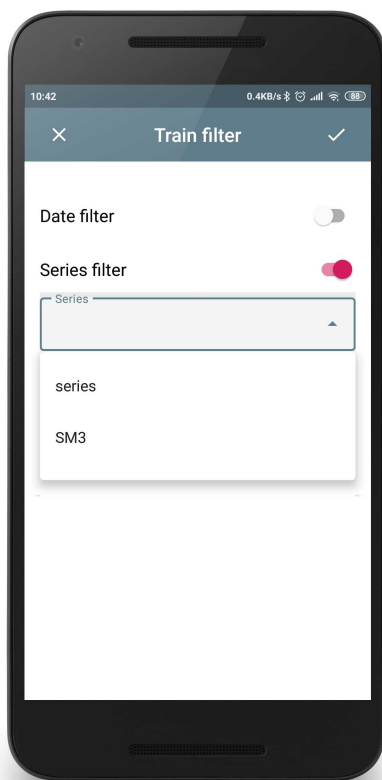

To delete the current filter, tap the filter button and disable the filter.

18.3. Deleting data

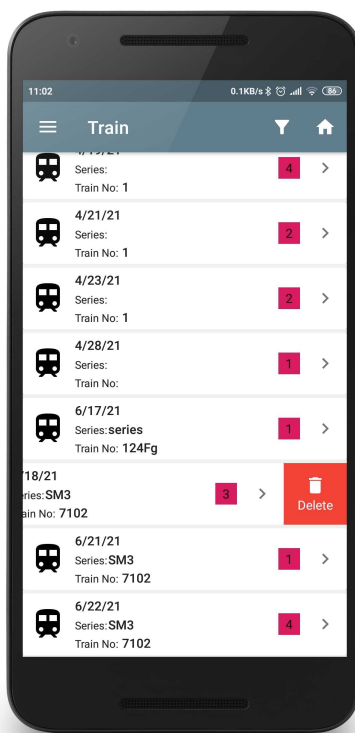

To delete a locomotive/car, swipe left from the right edge and tap **Delete**.

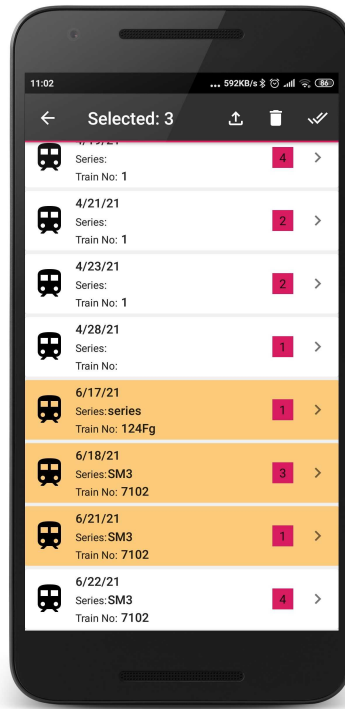

To delete some or all locomotives/cars, you need to tap and hold the item. Multiple selection mode will start.



Buttons:

-  - delete the selected items;
-  - select all;
-  - export the selected data to a PC (**Ikp5_db** program).

If the **Send email** option is selected in the settings, the following button is also available:

-  - send the selected data by email.

18.4. Viewing measurement results

To view the measurement results, tap on the required locomotive/car. A list of measurements for the selected locomotive/car will appear.



In this mode, the user can delete or export data.

18.4.1. Saving the wheel profile as the reference

The user can also save the profile of the selected wheel as a reference. To do this, swipe left over the item and tap **Save**.

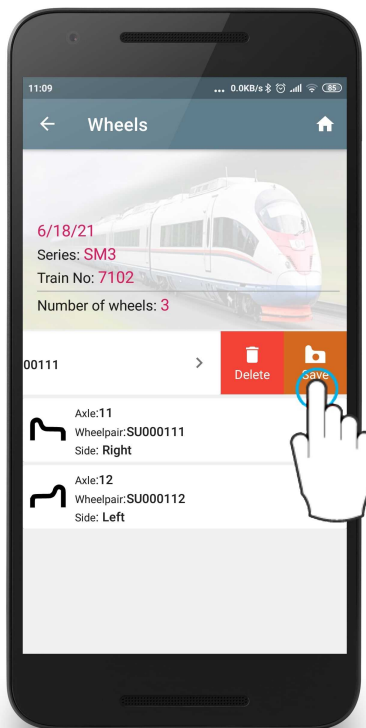

Then enter the name of the reference or agree with the proposed one (by default, the name is the locomotive/car series) and tap to save the reference.



The saved references are stored in the database: **Settings > References** (see par. [Reference profile](#)).

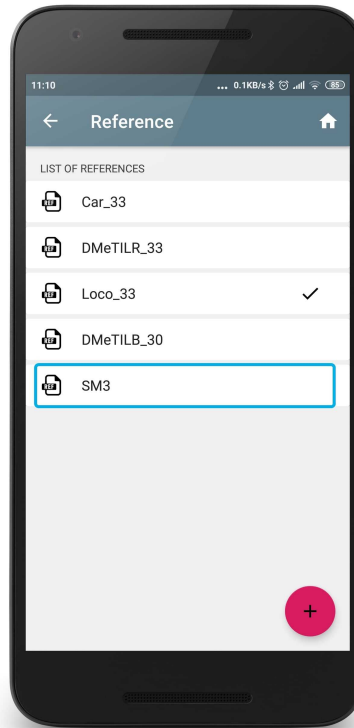

18.4.2. Viewing wheel parameters

To view the parameters and profile of the selected wheel, tap on the required item.



The window displays the identification data of the measured wheel, the measured profile and the calculated parameters. It is possible to disable the display of the reference profile - for this you need to clear the **Reference profile** check box.

18.4.3. Viewing the wheel profile

The profile can be zoomed in. To do this, touch the profile with two fingers at once and, without lifting the fingers from the screen, spread them apart.



19. Data exchange between PDA and a PC

To exchange data between a mobile device and a PC, select the device: **File > Device > Mobile Device**.

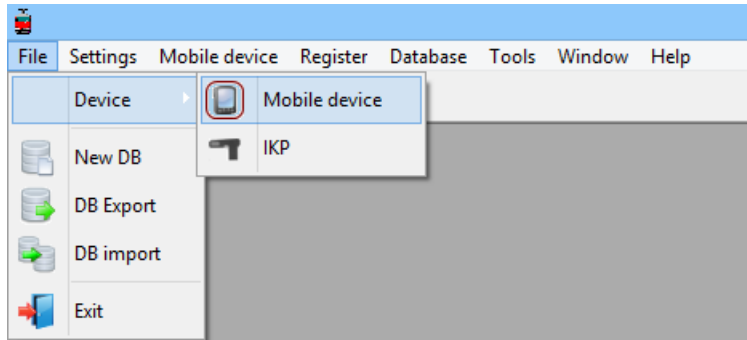

19.1. Synchronization of PDA and a PC

A Wi-Fi connection is used to transfer data between the mobile device
To connect you must do the following:

1. Select the synchronization type: **Mobile device > Synchronization > WiFi**.

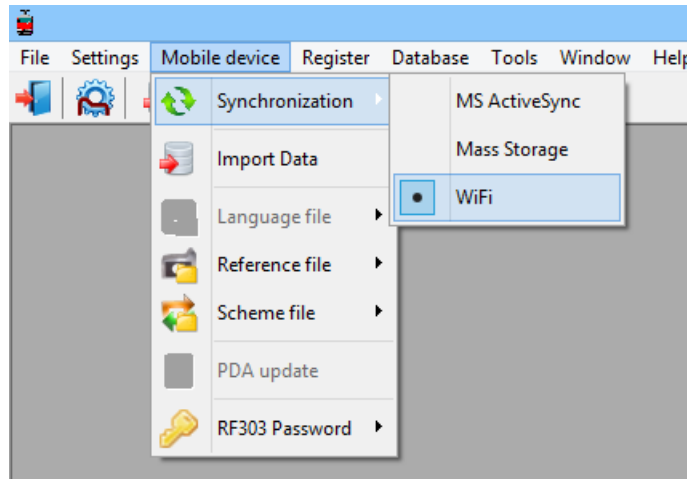

2. Go to server settings: **Settings > DB, Server settings.**

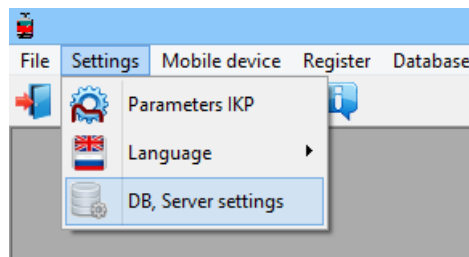

To transfer data, the PC and mobile device must be connected to the same Wi-Fi network. This can be a dedicated network created on an Android device (virtual hotspot) or any home/work network.

Ikp5_DB server port settings:

Port - port number for connecting a mobile device (**8090** by default)

The port number must be the same as specified in the mobile application (see par. PC server settings).

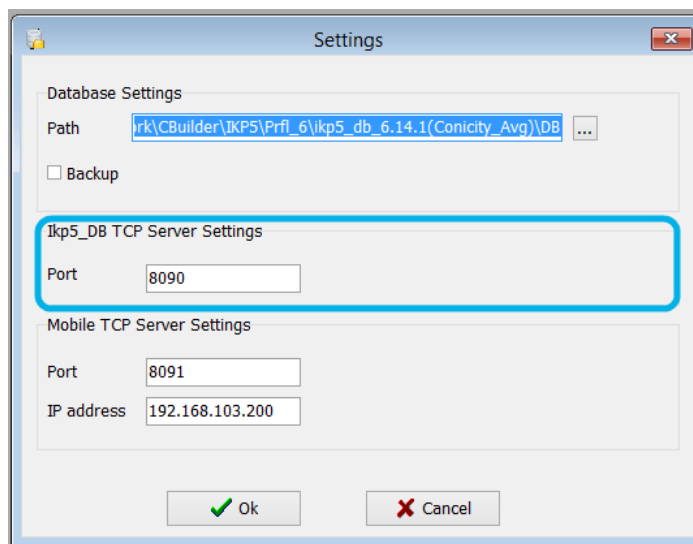

Mobile device server settings:

IP address and **Port** - address and port number of a mobile device in the network.

These values must be the same as specified in the mobile application (see par. Ikp server settings).

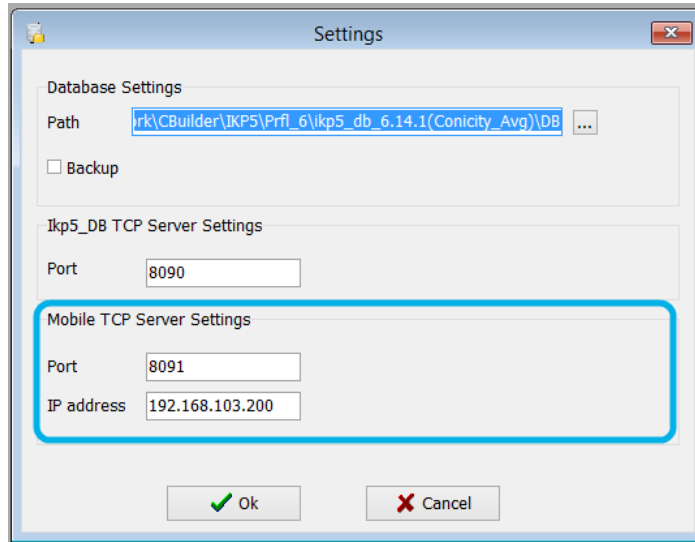

19.2. Data transfer

When you select to sync over Wi-Fi, the following options become available:

- Transferring the database file.
- Transferring the reference file.
- Transferring the scheme file.

19.2.1. Transferring the database file to a PC

When you sync data over Wi-Fi, the measurement results are exported from the **lkp** mobile app (see par. [Exporting data to PC](#)).

19.2.2. Transferring the reference file

To transfer the reference file from a PC to a mobile device, follow these steps:

- Select **Mobile device > Reference file > Export**.

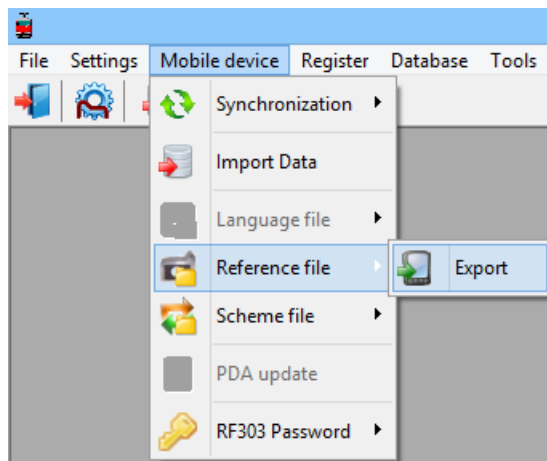

- Select the required file (*.ref).

If the data transfer is successful, the following message will appear:

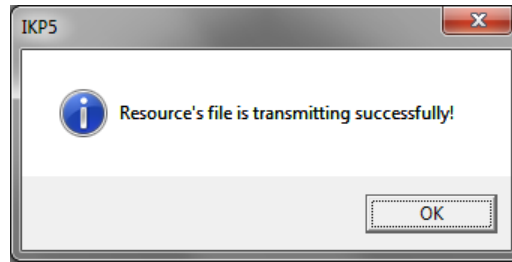

19.2.3. Transferring the scheme file

To transfer the scheme file from a PC to a mobile device, follow these steps:

- Select **Mobile device** > **Scheme file** > **Export**.

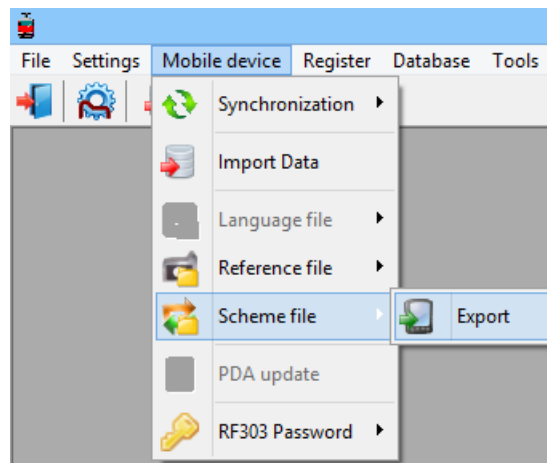

- Select the required file (*.sch).

If the data transfer is successful, the following message will appear:

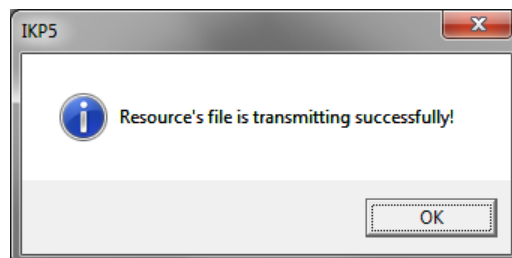

20. Installation of software on PC and startup

20.1. Installation of database support software

The **ikp5_DB** software is intended for maintaining wheel sets wear database on a personal computer (the updated version of the program can be downloaded from www.riftek.com/media/documents/ikp/Ikp5_PC_Software.zip).

To install the software, insert a compact disk to the PC CD drive, select and start the **Install_Ikp5.exe** file in the **Software** folder. Follow guidelines of the installation wizard. By default, the software will be installed in the following directory **C:\Program Files (x86)\Riftek, LLC\Ikp5_db**.

20.2. Synchronization of PDA and PC

There are two ways of synchronization via USB cable to transfer data between PDA and PC:

- MS ActiveSync

- Mass Storage

When you select **MS ActiveSync**, synchronization with PC is performed via the **ActiveSync** software (Windows XP), or via **Windows Mobile Device Center** (Windows 7), which must be installed on PC.

It is necessary to select **MS ActiveSync** as the synchronization type.

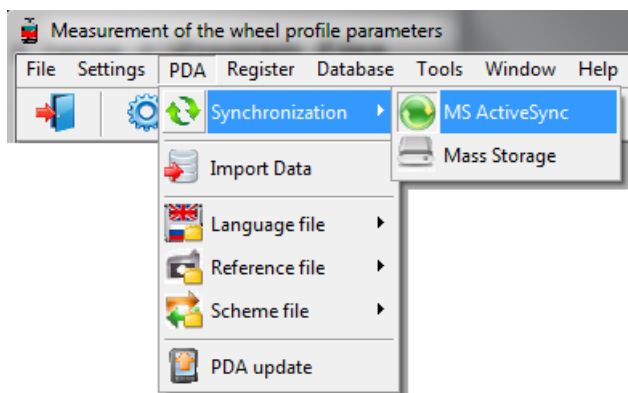

When you select **Mass Storage**, the device will be detected in Windows as an external storage device.

It is necessary to select **Mass Storage** as the synchronization type.

To check if the **MS ActiveSync** synchronization is correct, switch on the PDA and connect it to the USB port of the PC by the supplied cable. If the connection is successful, a message about it will appear on the screen:

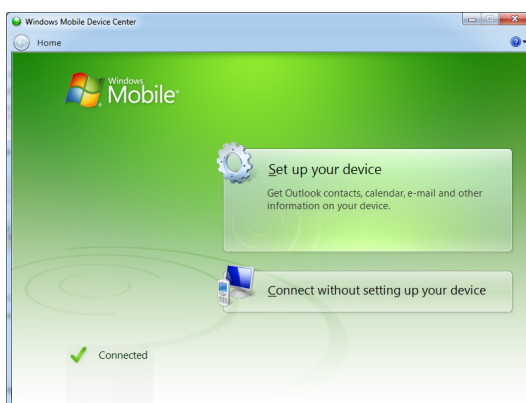

20.3. Program startup

To start the program, click **Start > All programs > Riftek, LLC > IKP5_DB > Ikp5_DB.exe**. View of the main program window is shown below.

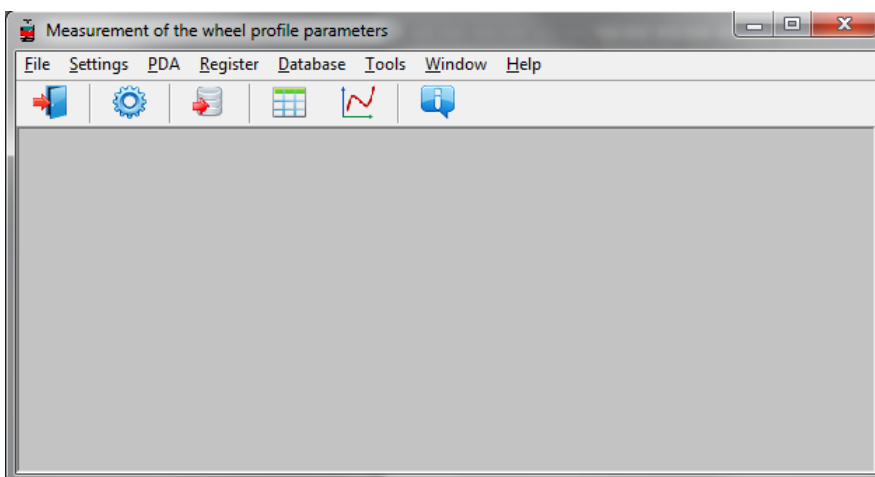

21. User settings of the program

21.1. Parameters setting

To go to the window of parameters setting, click **Settings > Parameters** in the main window, or click .

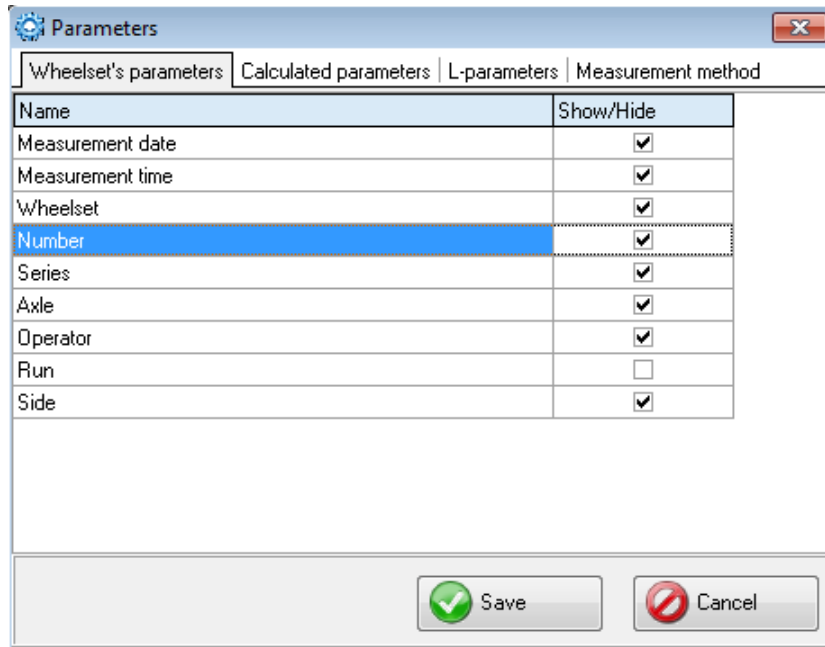

The window of parameters contains 4 tabs:

- Wheelset's parameters
- Calculated parameters
- L parameters
- Measurement method

21.1.1. "Wheelset's parameters" tab

This tab is intended to select parameters, which will be displayed on the screen when viewing the database.

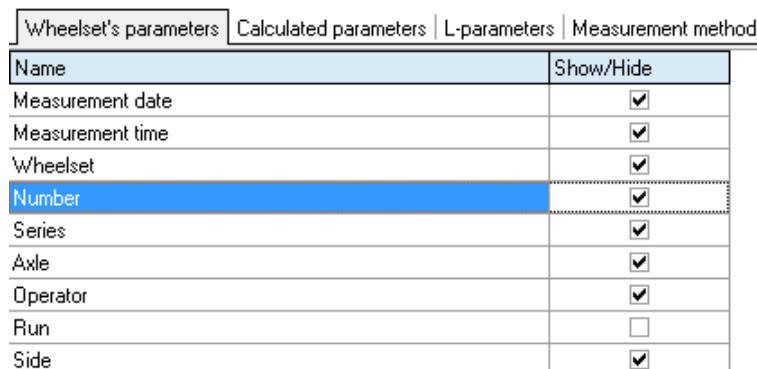

Name	Show/Hide
Measurement date	<input checked="" type="checkbox"/>
Measurement time	<input checked="" type="checkbox"/>
Wheelset	<input checked="" type="checkbox"/>
Number	<input checked="" type="checkbox"/>
Series	<input checked="" type="checkbox"/>
Axle	<input checked="" type="checkbox"/>
Operator	<input checked="" type="checkbox"/>
Run	<input type="checkbox"/>
Side	<input checked="" type="checkbox"/>

If the parameter is ticked, its value will be shown in the table of results and in the table of profiles.

21.1.2. "Calculated parameters" tab

This tab is intended to select the wheelset geometrical parameters, which will be calculated and displayed on the screen when viewing the database.

Wheelset's parameters		Calculated parameters	L-parameters	Measurement method
Name				Show/Hide
Height (sH)				<input checked="" type="checkbox"/>
Thickness (sD)				<input checked="" type="checkbox"/>
Thickness (sD1)				<input checked="" type="checkbox"/>
Parameter (sF)				<input checked="" type="checkbox"/>
Gradient (qR)				<input checked="" type="checkbox"/>
Diameter (D)				<input checked="" type="checkbox"/>
Tire (T)				<input type="checkbox"/>
Slope (SI)				<input type="checkbox"/>
Angle (A)				<input type="checkbox"/>
Hollow (HI)				<input type="checkbox"/>
Rim width (L)				<input type="checkbox"/>
Wear (Wt)				<input type="checkbox"/>
Back-to-Back distance (M)				<input type="checkbox"/>
Multiple measurements (M)				<input type="checkbox"/>

Description and functions of parameters are the same as in the PDA software (see par. 10.).

21.1.3. "L-parameters" tab

This tab is intended to set the values of reference points for calculated geometrical parameters of the wheelset.

Wheelset's parameters		Calculated parameters	L-parameters	Measurement method
Code	Value			
Parameter L1	2,00	mm		
Parameter L2	70,00	mm		
Parameter L3	13,00	mm		
Parameter L10	14975,00	mm		
Parameter L15	15,00	mm		

Description and functions of the reference points are the same as in the PDA software (see par. 10.).

21.1.4. "Measurement method" tab

This tab is intended to select the calculation method.

Wheelset's parameters		Calculated parameters	L-parameters	Measurement method
Parameter L3 from:		Thickness from:		
<input checked="" type="radio"/> Rolling circle <input type="radio"/> Flange		<input checked="" type="radio"/> Inner surf. <input type="radio"/> Flange <input type="radio"/> Both values		
Gradient:		Wear:		
<input checked="" type="radio"/> From L1 to L3 <input type="radio"/> From L1 to L4		<input checked="" type="radio"/> Height <input type="radio"/> Equal./Unequal		
Gradient in:		Coordinates center:		
<input checked="" type="radio"/> Millimeters <input type="radio"/> Degrees <input type="radio"/> Accept./Unaccept.		<input checked="" type="radio"/> Flange top <input type="radio"/> Rolling circle		
Units measure		Inverted profile		
<input checked="" type="radio"/> mm <input type="radio"/> inch		<input checked="" type="radio"/> No <input type="radio"/> Yes		

Description and functions of the measurement methods are the same as in the PDA software (see par. 10.).

21.1.4.1. Selection of measurement units

All parameters and measurement results can be in the Metric system (millimeters), or in the English system (inches).

To set the units of measurement, you need to select **mm** or **inches** in the **Units of measurement** field. After saving the changes, all information will be displayed in the selected units of measurement.

21.2. Database settings

21.2.1. Setting the path to database

It is possible for the user to change the drive and the directory of the profiles database storage. In the main window, select **File > Path to DB...**

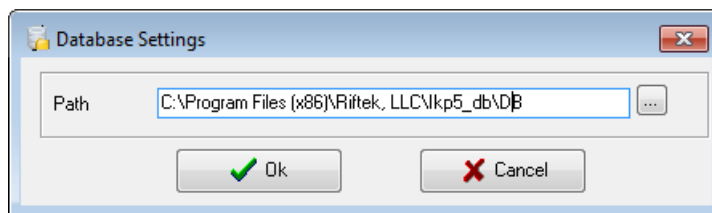

Next:

- click **Ok**
- specify a new path to the database
- confirm the creation of a new database

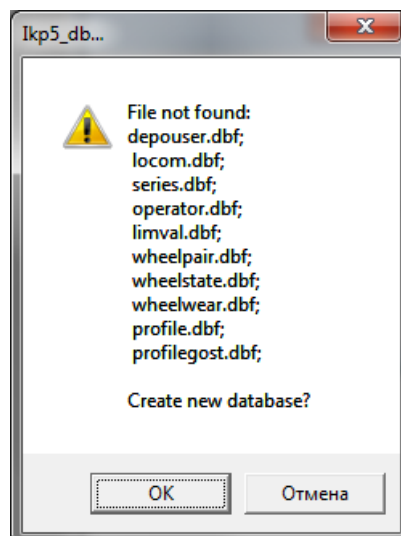

All database files will be copied to the specified path.

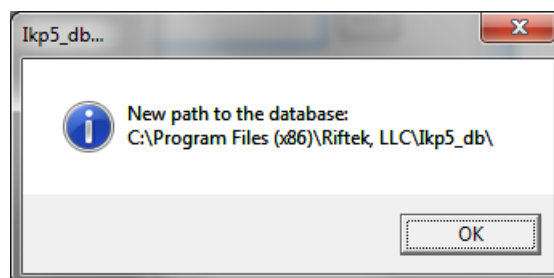

21.2.2. Creation of empty database

To create an empty database, select **File > New DB**.

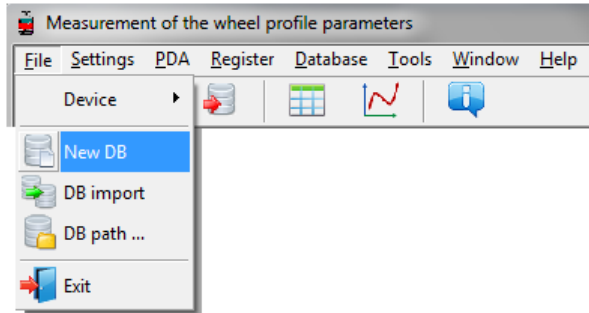

All data except the reference files will be deleted from the database. At the same time, the **DB(dd.mm.yy)** directory will be created in the installation directory whereto all the deleted data will be copied (**dd.mm.yy** – current date). If necessary, these data can be restored (see par. [21.2.3](#)).

21.2.3. Import of database

To import data to the database from the other database, you need to:

- Select **File > Import Data**.
- Select the directory with DB files in the left window. All files will appear in the right window:

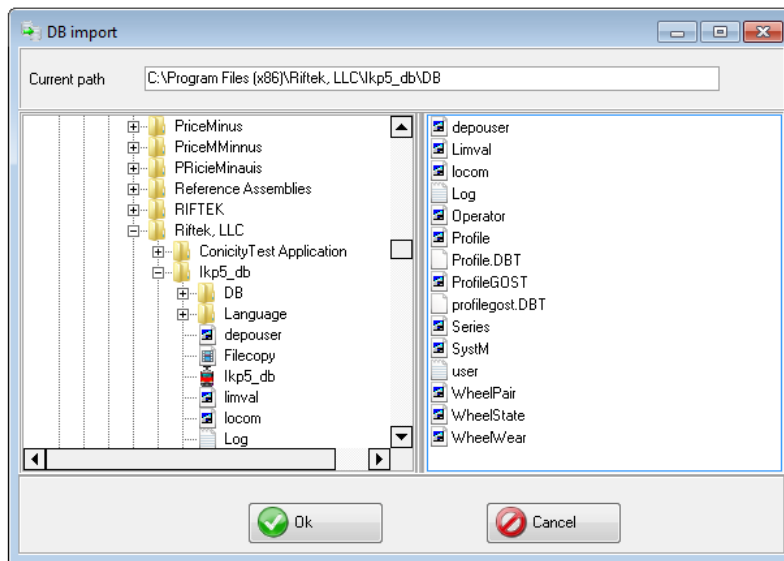

- Click **OK** to import data.

21.2.4. Selection of software language

To change the software language, select **Settings > Language** and select the required language support file.

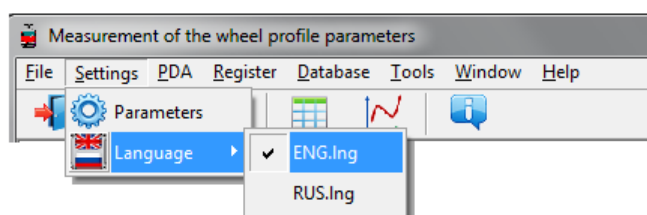

21.2.4.1. Preparation and installation of the language support file

The user can change the language, form his own language support files as well as change/edit the terminology used. Language support files are located in the directory used in the process of installation. By default, the following directory is used: **C:\Program Files (x86)\Riftek, LLC\lcp5_db\Language**.

The directory contains two files, **RUS.Ing** and **ENG.Ing**, to support Russian and English languages respectively.

To create the support file for any other language, it is necessary to:

- copy one of the existing files, for example - **ENG.Ing**, under the other name, for example - **DEU.Ing**;
- edit the renamed file by using any text processor, namely, change all terms and phrases to analogous ones from the required language;
- save the edited ***.Ing** file in the **Language** directory.

To change and edit terminology, it is necessary to:

- edit the corresponding language file by using any text processor;
- save the edited ***.Ing** file in the **Language** directory.



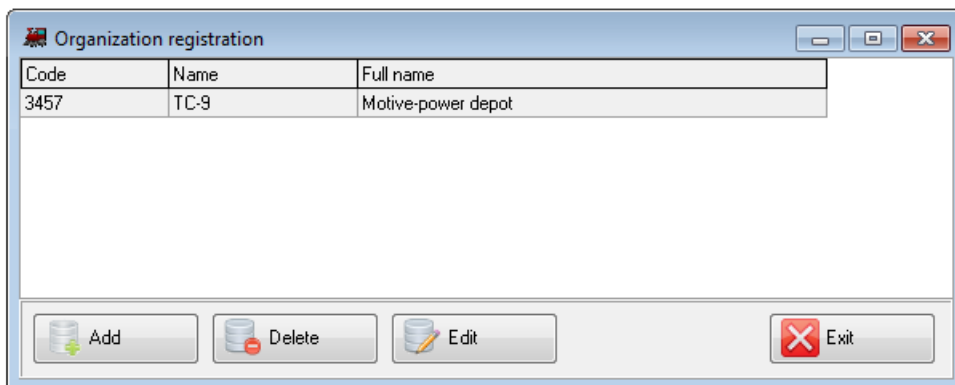

21.3. Registration data

21.3.1. Selection of the organization

To add/chose the user organization, select **Registration > Organization**. Subsequently, this information will be used in automatic generation of reports.



Buttons:

 Add	Add a new organization
 Delete	Delete the selected organization
 Edit	Edit the selected organization
 Exit	Exit the mode

To select a current organization:

- Click **Edit**
- Tick the depot
- Click **Save**

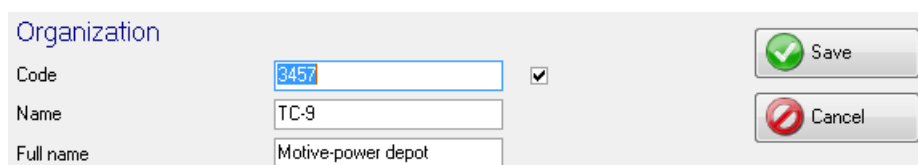

21.3.2. Registration of operators

Steps to follow: **Registration > Operator**. Operators data are used for identifying operators by **Number**.

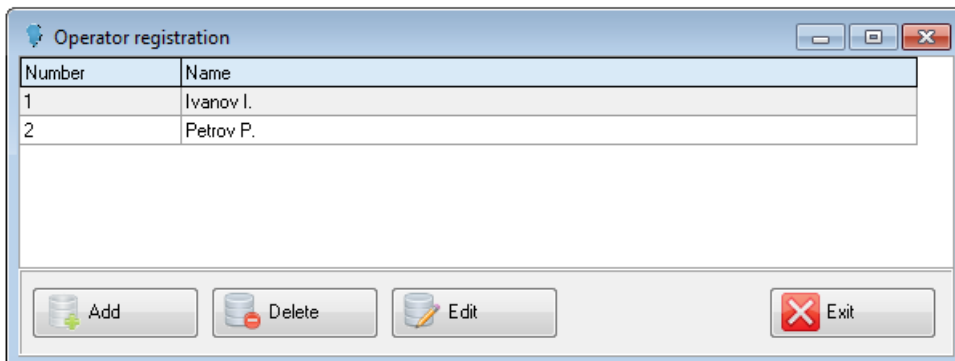

Functions of buttons are similar to those in par. [21.3.1](#).

21.3.3. Registration of series

Steps to follow: menu **Registration > Series**. Registered series of cars or locomotives are displayed in the emerged window.

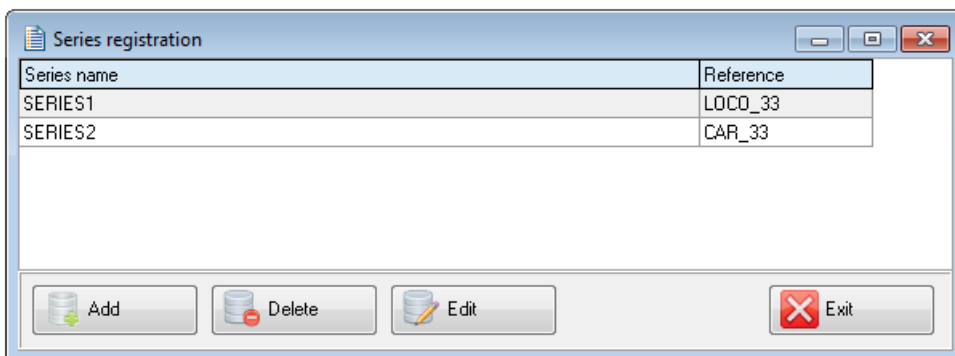

When registering a new series, a new entry for this series will be added in the table of tolerances automatically (see par. [21.3.5](#)).

Functions of buttons are similar to those in par. [21.3.1](#).

When adding a new series, it is necessary to enter the name of the series and to select the reference profile for it. Flange parameters of the selected profile will be calculated and added to the table of tolerances automatically after saving the series (see par. [21.3.6](#)).

21.3.4. Registration of car/locomotive numbers

Steps to follow: menu **Registration** > **Number**. Registered numbers of cars/locomotives are displayed in the emerged window.

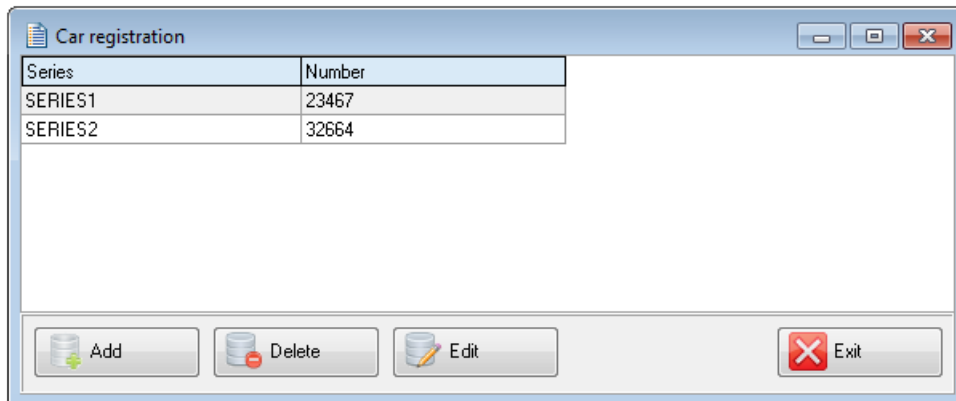

Functions of buttons are similar to those in par. [21.3.1.](#)

21.3.5. Registration of tolerances

Steps to follow: menu **Registration** > **Tolerance**. Registered series of cars/locomotives with boundary values of calculated geometric parameters of the wheelset are displayed in the emerged window.

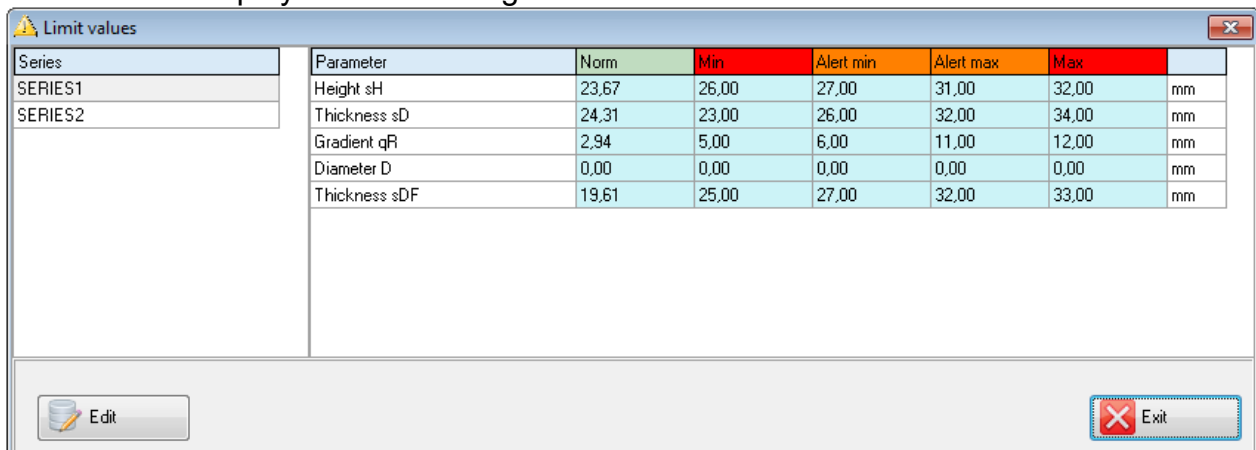

Series	Parameter	Norm	Min	Alert min	Alert max	Max	
SERIES1	Height sH	23,67	26,00	27,00	31,00	32,00	mm
SERIES2	Thickness sD	24,31	23,00	26,00	32,00	34,00	mm
	Gradient qR	2,94	5,00	6,00	11,00	12,00	mm
	Diameter D	0,00	0,00	0,00	0,00	0,00	mm
	Thickness sDF	19,61	25,00	27,00	32,00	33,00	mm

Only parameters, which were selected in the list of parameters, are available for editing (see par. [21.1.2.](#)).

Maximum/minimum critical values of parameters are indicated with a red color. An orange color indicates maximum/minimum values of parameters, which are close to critical.

The **Norm** value is calculated and added to the table automatically when adding/editing the series of the selected reference (see par. [21.3.3.](#)).

21.3.6. Registration of reference profiles

The program comes with several preset profiles. In addition, the supplied disc with software contains the base of reference profiles. Profiles are in the **Reference Profiles** directory and divided into separate directories for each country.

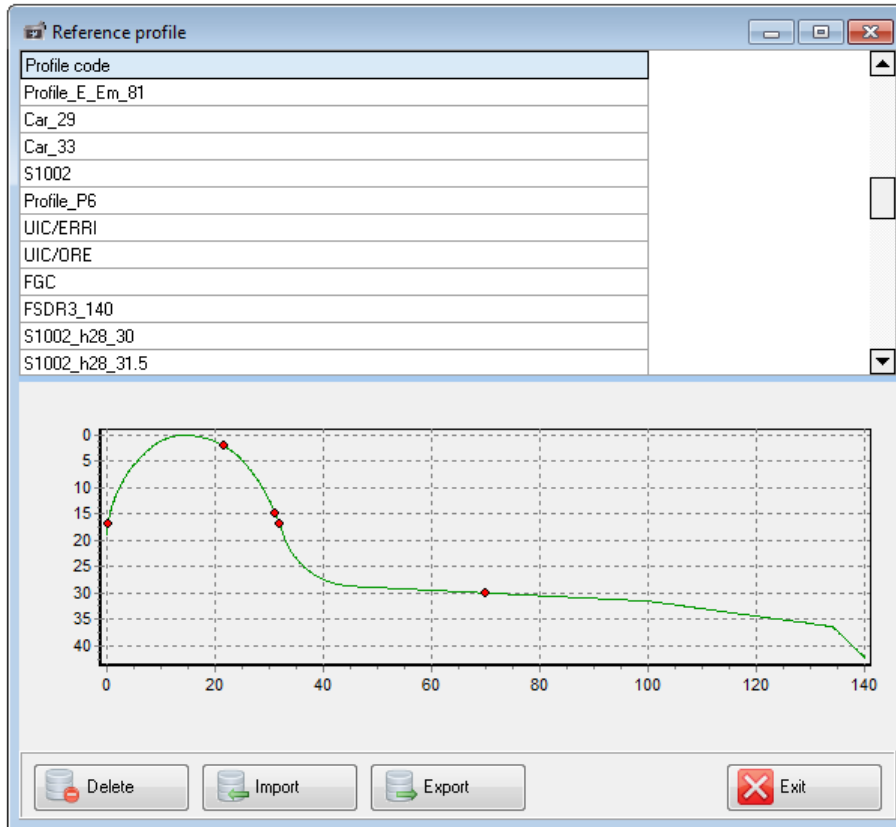

In addition, the user can form a description of the required profile himself or request it from **RIFTEK** (free service).

To browse available profiles, select **Registration** > **Reference**:



The window of profiles displays the table with the list of reference profiles, saved to database, and a graphical view of the selected profile.

Buttons:

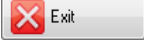
 Delete	Delete the reference profile
 Import	Import the reference profile from *.ref file
 Export	Export the reference profile to *.ref file
 Exit	Exit the mode

21.3.6.1. Request and registration of the profile file

To get .ref file of reference profile send the drawing of profile to **RIFTEK** (info@riftek.com). Register the received .ref file as follows:

- click **Import**
- in the window appeared indicate the way to the .ref-file
- click **Open**

The profile will be added to the base of reference profiles.

22. Data exchange between PDA and PC

To exchange data between PC and PDA, you need to select the device: **File > Device > RF303M-PDA**.

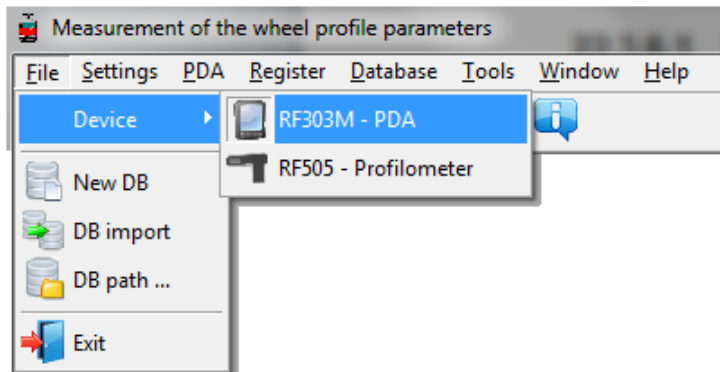

Data exchange between PC and PDA is performed by means of direct cable connection of PDA to PC USB-port (special **RF505.42** cable is supplied).

There are two ways of synchronization via USB cable:

- ActiveSync
- Mass Storage

For more details see par. [20.2](#).

22.1. ActiveSync synchronization

When you select this type of synchronization, additional features of data exchange with PDA will be available:

- Transfer of database files to PC.
- Transfer of language files.
- Transfer of reference profile files.
- Transfer of processing scheme files.
- PDA software update.

22.1.1. Transfer of database file to PC

To transfer the database file from PDA to PC, it is necessary to:

- Select **PDA > Import Data**.

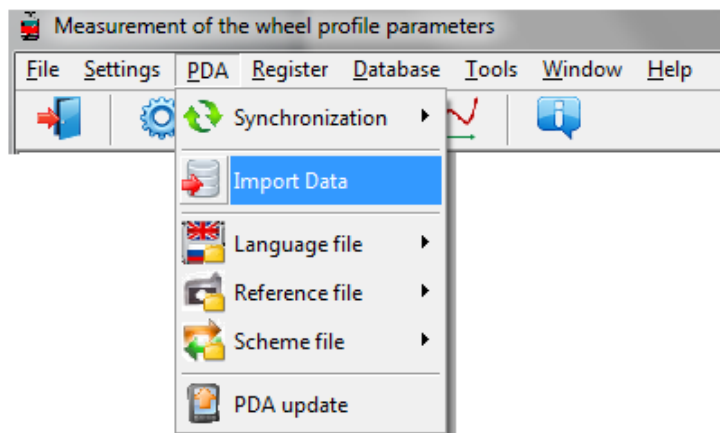

- Mark the required files in the emerged window and click **OK**.

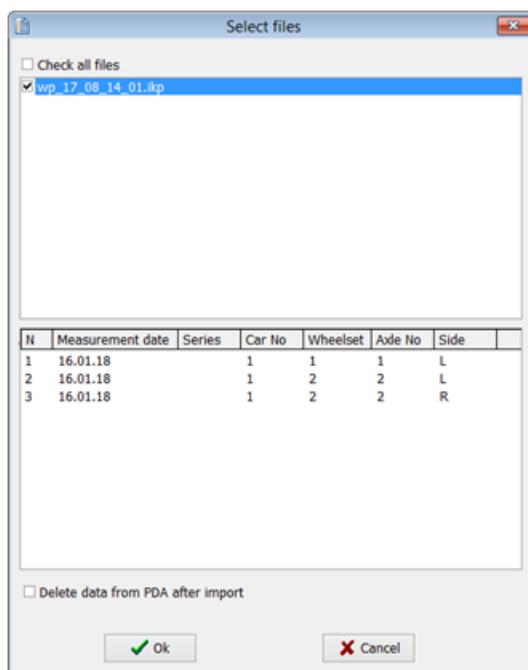

 Double-click on the selected file in order to see information about saved data.

22.1.2. Transfer of language file from PC to PDA

To transfer the language file from PC to PDA, it is necessary to:

- Select **PDA > Language file > Export**.

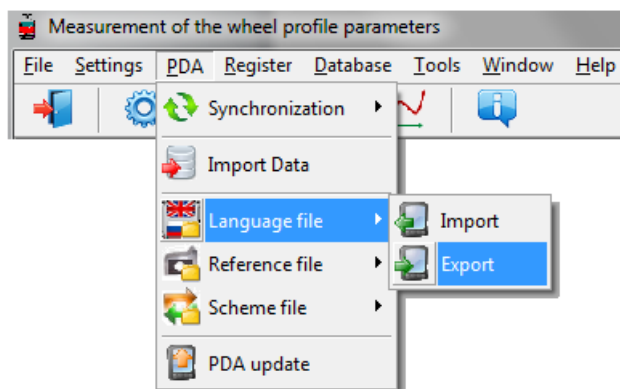

- Select the required file.

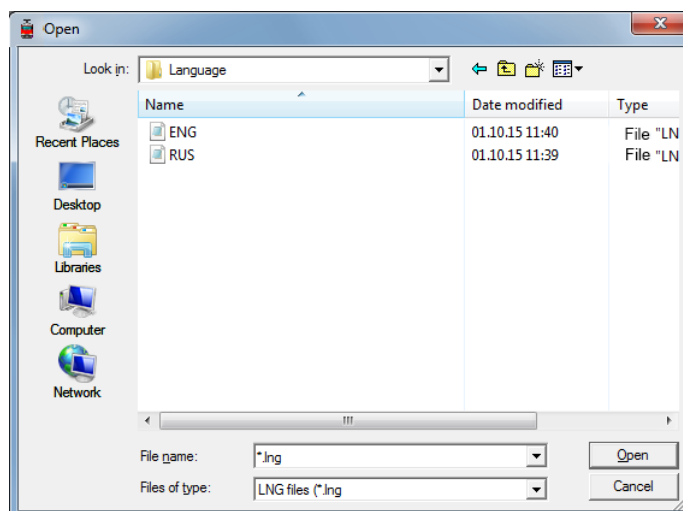

If transfer is successful, the screen will show:

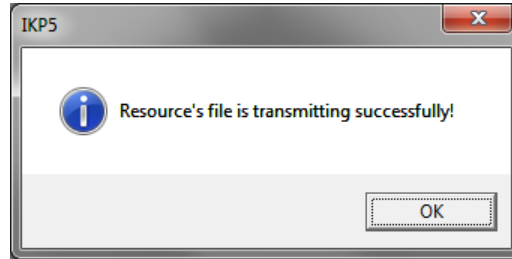

22.1.3. Transfer of language file from PDA to PC

To transfer the language file from PDA to PC, it is necessary to:

- Select **PDA > Language file > Import**.

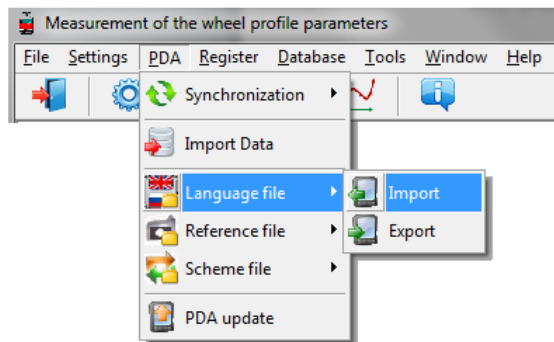

- Select the required file.

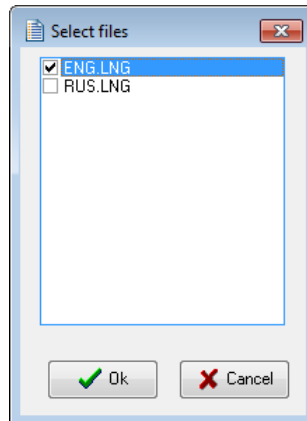

If transfer is successful, the selected files will be saved to the specified path.

22.1.4. Transfer of reference profile files from PC to PDA

To transfer the reference profile file from PC to PDA, it is necessary to:

- Select **PDA > Reference file > Export**.

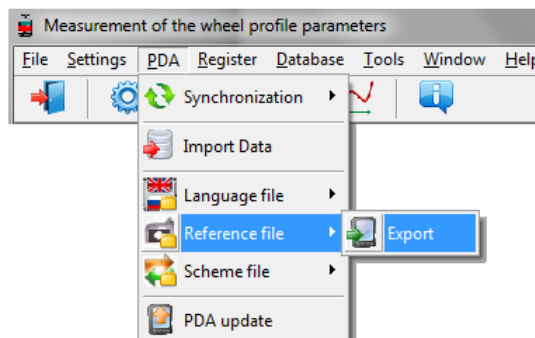

- Select the required **.ref** file.
- If transfer is successful, the screen will show:

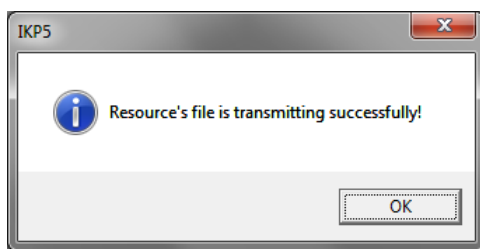

22.1.5. Transfer of processing scheme file from PC to PDA

To transfer the processing scheme file from PC to PDA, it is necessary to:

- Select **PDA > Scheme file > Export**.

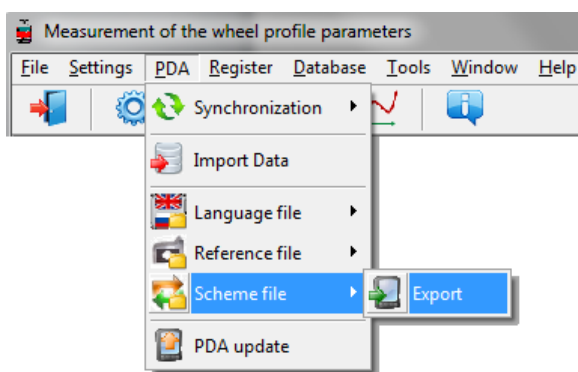

- Select the required **.sch** file.
- If transfer is successful, the screen will show:

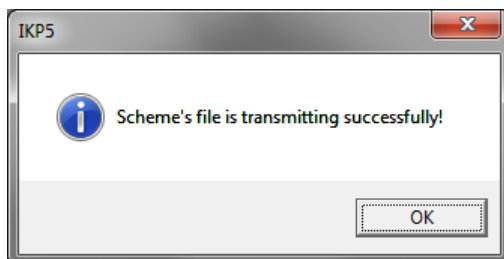

22.1.6. Updating of PDA software

The latest software version can be downloaded from the website:

www.riftek.com/media/documents/ikp/lkp5_PDA_Software.zip.

To transfer the update file to PDA, it is necessary to:

- Select **PDA > PDA update**.

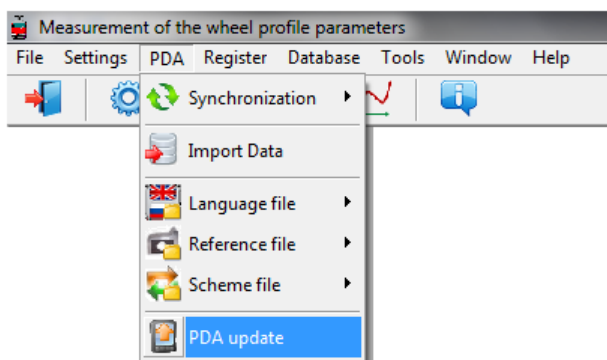

- Select file for transfer.

If transfer is successful, the window will appear:

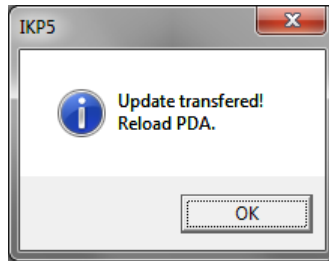

22.2. Mass Storage synchronization

When you select this type of synchronization, PDA is detected as an external storage device. Therefore, only the **Import Data** item is active. Transfer of language/scheme/reference files from PDA to PC and back can be performed by simple copying.

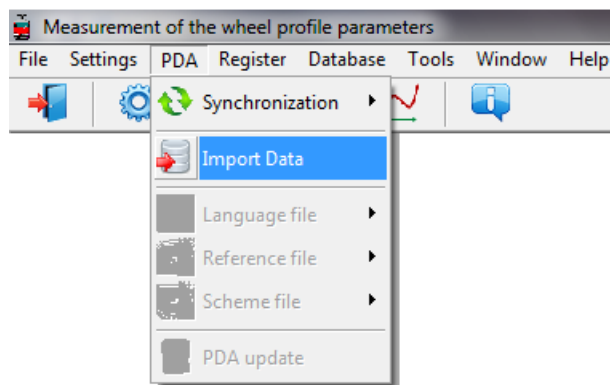

To transfer database files from PDA to PC, it is necessary to:

- Select **PDA > Import Data**.
- Specify the path to the database on PDA (by default, **SDMMC\Autorun\DB**).

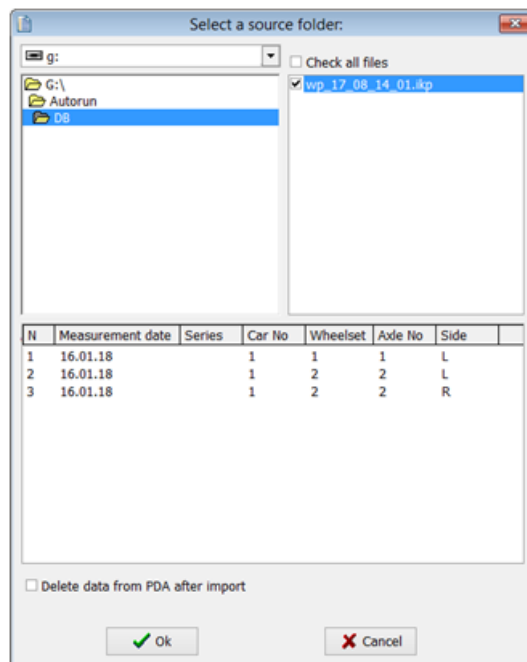

- Mark the required files in the emerged window and click **OK**.



Double-click on the selected file in order to see information about saved data.

23. Working with profilograms and wear calculations

23.1. Browsing the graph and profile coordinates



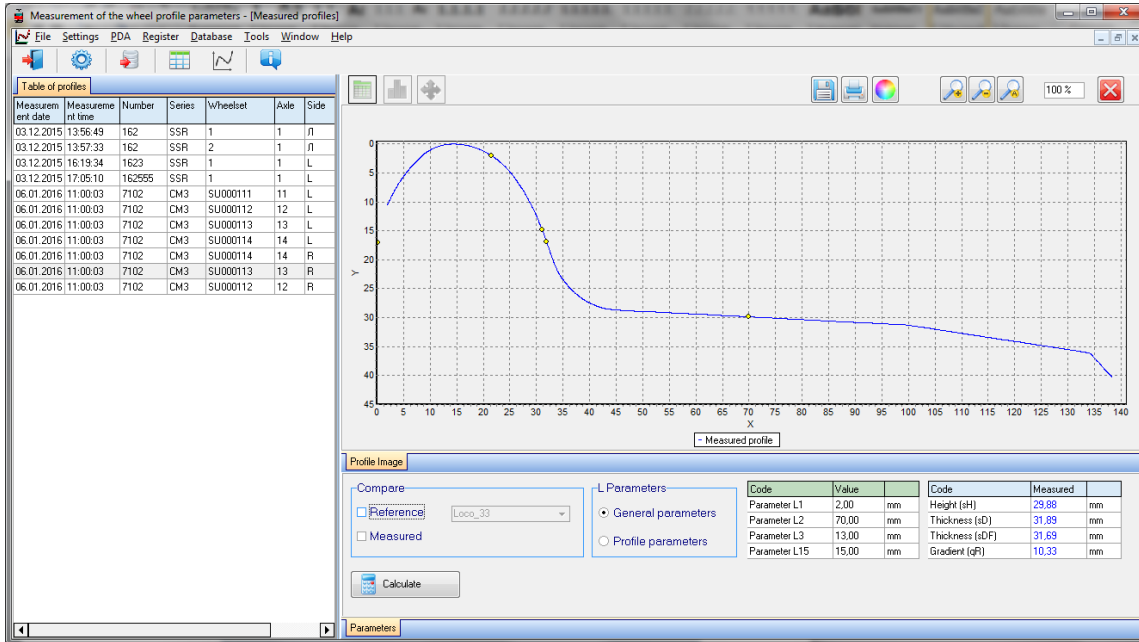



To browse the saved profiles of the rolling surface, select **Database > Profiles**, or click the **Profiles** button - .



At the left side of the window you can see the **Table of profiles** tab, which contains a list of saved profiles. The table displays only those identification parameters of the wheel, which were selected in the parameters window (see par. 21.1.).

When selecting a profile, it is possible to browse a graphical image and geometric parameters of the measured wheel. To browse the coordinates of the selected profile, you need to click the **Profile Values** button. After that, an additional tab with the measured coordinates will appear.

Buttons:

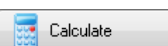
	Show/hide the Wear graph
	Show/hide the Profile Values tab
	Show/hide the Profile alignment tab
	Save the profile image to file (.bmp file)
	Print the profile image
	Change the background color of the graph
	Zoom in/out the profile graph
	Calculate geometric parameters of the wheel

23.2. "Parameters" tab

Calculated geometric parameters of the profile as well as L-parameters values are displayed on the **Parameters** tab, which is at the bottom of the window.

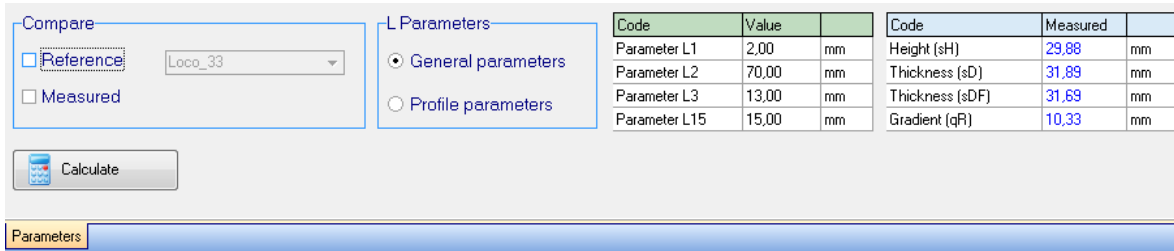

If needed it is possible to change settings of the calculated parameters or support points (see par. [21.1](#)).

23.2.1. Selecting a profile to compare

There are two ways to compare:

- with the reference profile,
- with the measured profile.

To compare the measured profile with the reference one, it is necessary to tick the **Reference** box.

When comparing with the reference profile, select the required reference profile in the drop-down list.

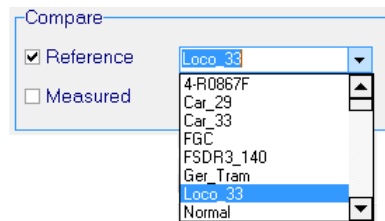

To compare two measured profiles (for example, profiles of left and right wheels), it is necessary to tick the **Measured** box. The **Table of profiles** tab will show an additional table for selecting a profile to compare.

23.2.2. Selecting L-parameters values

When calculating the geometric parameters of wheelsets, the specified support points are used (see par. [21.1.3](#)). There are two variants of L-parameters:

- General parameters
- Profile parameters

When selecting **General parameters**, values of L-parameters will be taken from the default parameters file (see par. [21.1.3](#)).

When selecting **Profile parameters**, values of L-parameters will be taken from the profile file, i.e. the values, which were set in PDA when measuring the wheelset.

Values of L-parameters are displayed on the screen in the table of parameters.

Code	Value	
Parameter L1	2,00	mm
Parameter L2	70,00	mm
Parameter L3	13,00	mm
Parameter L15	15,00	mm

If necessary, it is possible to edit any value and to recalculate values of geometric parameters of the flange. To do it, click **Calculate**. Parameters of the measured profile and selected reference will be recalculated.

23.2.3. Geometric parameters of the profile

The table of calculated geometric parameters displays only those parameters, which were selected in the parameters window (see par. 21.1.2).

Code	Measured	Reference	
Height (sH)	29,87	28,00	mm
Thickness (sD)	31,89	32,32	mm
Gradient (qR)	10,33	9,10	mm

Parameters, which are beyond the set tolerances, are highlighted in red/orange (see par. 21.3.5).

23.3. Wear calculation

23.3.1. Fast wear calculation

To obtain fast calculation of the profile wear at a certain point relative to the reference, put cursor bar to any of the profiles, and when a cross-like (+) mouse cursor appears press the left mouse key. The resulting screen will show the value of the coordinate difference between profiles taken along X- and Y-axes, as shown by arrows:

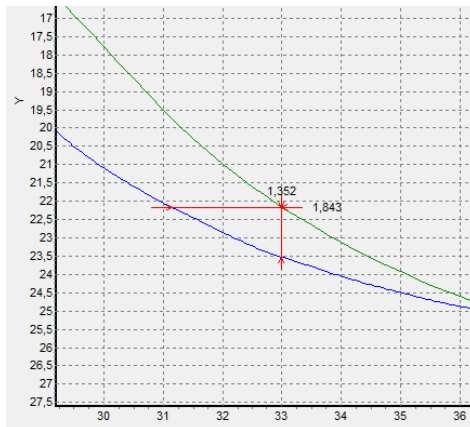

To remove size indication from the screen, it is necessary to put cursor to any of the profiles and press the right mouse key.

23.3.2. Wear calculation at all points

To calculate the wear at all points of the measured profile, it is necessary to click the **Wear** button. Calculated wear will be displayed on the screen in a graphic form:

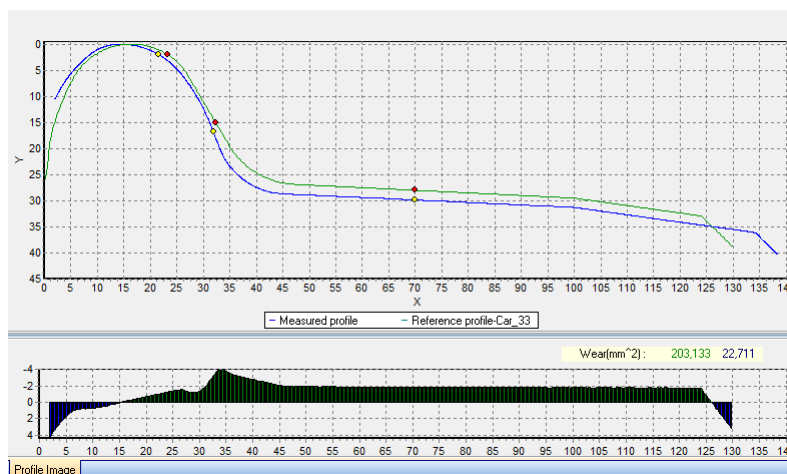

The graph displays positive and negative values of the wear area. Value of the wear area is calculated in square millimeters with respect to the selected reference profile:

Wear(mm²): 203,133 22,711

To view the table of wear values, it is necessary to select **Profile Values > Wear**. The table will show deviations of the selected profile from the reference profile in two directions (X and Y).

N	Values		Measured	Reference		Wear
	on axis X	on axis Y		on axis X	on axis Y	
1	1,56	11,35	1,61	11,31	11,57	0,26
2	1,61	11,31	1,86	10,90	10,96	0,06
3	1,66	11,26	2,11	10,31	10,40	0,09
4	1,71	11,21	2,36	9,74	9,87	0,13
5	1,76	11,11	2,61	9,22	9,36	0,13
6	1,81	11,02	2,86	8,81	8,90	0,10
7	1,86	10,91	3,11	8,40	8,45	0,06
8	1,91	10,79	3,36	7,95	8,01	0,06
9	1,96	10,67	3,61	7,50	7,59	0,10
10	2,01	10,56	3,86	7,10	7,22	0,13
11	2,06	10,44	4,11	6,72	6,85	0,13
12	2,11	10,32	4,36	6,37	6,50	0,13
13	2,16	10,21	4,61	6,06	6,16	0,09
14	2,21	10,09	4,86	5,75	5,82	0,07
15	2,26	9,98	5,11	5,41	5,50	0,09
16	2,31	9,86	5,36	5,08	5,20	0,12
17	2,36	9,75	5,61	4,80	4,89	0,09
18	2,41	9,64	5,86	4,56	4,62	0,06
19	2,46	9,54	6,11	4,29	4,33	0,04
20	2,50	9,44	6,36	4,01	4,06	0,05
21	2,56	9,34	6,61	3,74	3,81	0,07
22	2,60	9,24	6,86	3,47	3,56	0,09
23	2,65	9,15	7,11	3,23	3,32	0,08
24	2,70	9,07	7,36	3,02	3,08	0,06
25	2,75	8,99	7,61	2,81	2,85	0,04
26	2,80	8,91	7,86	2,60	2,63	0,03

111

23.3.3. Export to Excel, DXF, REF

To export the table to the Excel or DXF format or to create the reference file (REF), it is necessary to right-click on the table. The pop-up menu will appear:

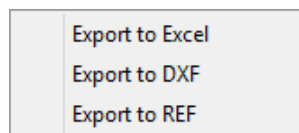

Select the needed menu item.

23.4. Alignment of profiles

For alignment (vertical translation) of profiles, you need to click the **Alignment** button. The program will display an additional tab, where you can select a profile: **Reference** or **Measured**. The selected profile will be marked with red.

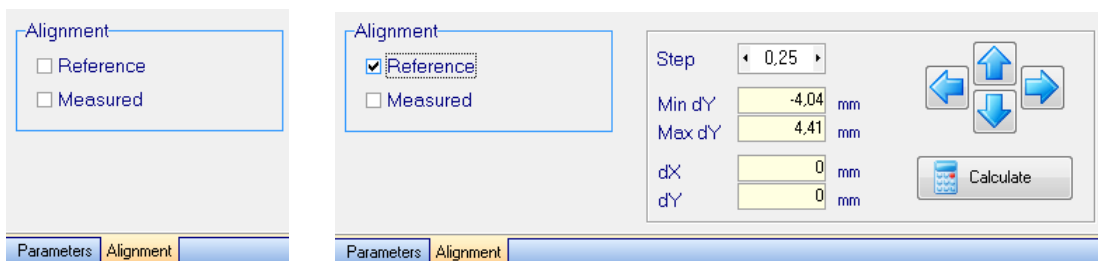

After selecting the profile, the screen will display the maximum and minimum deviations of the selected profile from the reference profile [Min dY..Max dY].

Next, specify the translation step and move the profile by using the **Up/Down, Left/Right** buttons.

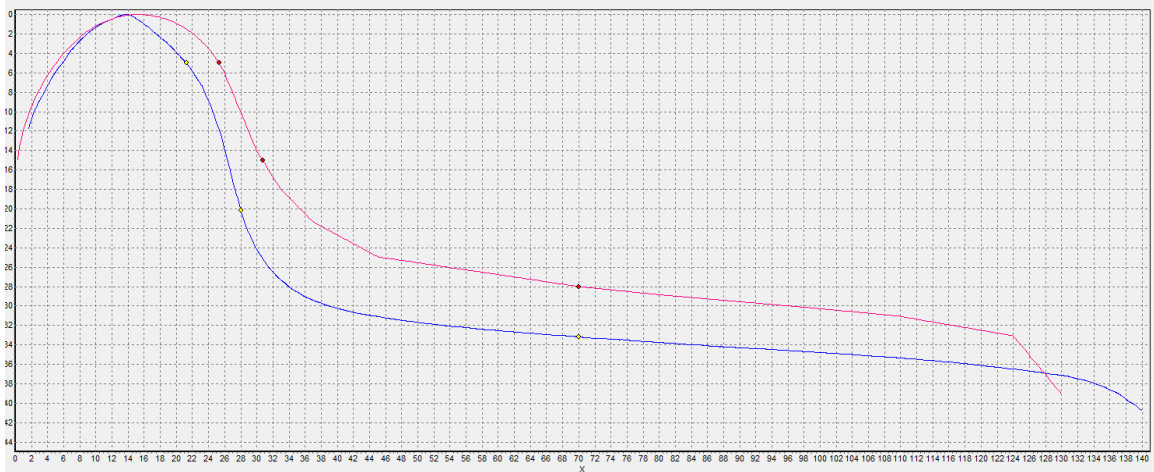

To save the changed profile, go to the tab of identification parameters of the profile and click **Save**.

Table of profiles **Save**

Wheel parameters

Organization: sjdjsfjk dsfkdsjfhdskf sdfj

Measurement date: 06.01.16

Series: CM3

Number: 7102

Wheelset: SU000111

Axle: 11

Side: L

Operator:

Mileage: 1111

Save

To create a new profile, it is necessary to change the identification parameters of the profile.



23.5. Superposition of profiles

To superimpose several changed profiles, you need to tick the required profiles in the left table. Selected profiles will be displayed in different colors.

Measurement date	Measurement time	Number	Wheelset	Side	Selected
03.12.2015	13:56:49	162	1	R	<input type="checkbox"/>
03.12.2015	13:57:33	162	2	R	<input type="checkbox"/>
03.12.2015	16:19:34	1623	1	L	<input type="checkbox"/>
03.12.2015	17:05:10	162595	1	L	<input type="checkbox"/>
06.01.2016	11:00:33	7102	SU000111	L	<input checked="" type="checkbox"/>
06.01.2016	11:00:03	7102	SU000112	L	<input checked="" type="checkbox"/>
06.01.2016	11:00:03	7102	SU000113	L	<input checked="" type="checkbox"/>
06.01.2016	11:00:03	7102	SU000114	L	<input checked="" type="checkbox"/>
06.01.2016	11:00:03	7102	SU000114	R	<input checked="" type="checkbox"/>
06.01.2016	11:00:03	7102	SU000113	R	<input checked="" type="checkbox"/>
06.01.2016	11:00:03	7102	SU000112	R	<input checked="" type="checkbox"/>

Code	Value	Code	Measured	Reference
Parameter L1	2.00 mm	HegH4 (µH)	24.67	29.68 mm
Parameter L2	70.00 mm	Thickness (D)	31.89	30.79 mm
Parameter L3	13.00 mm	Thickness (Df)	28.44	28.36 mm
		Gradient (µH)	0.44	1.08 mm
		Wear (vH)	0.19	0.00 mm
		Wear (vH)	0.03	0.00 mm

23.6. Rescaling

To change the image scale, mark a part of the image with the left mouse key, move the image by holding it with the right mouse key pressed, or with buttons **Increase** -  , **Decrease** -  and **Show all** - .

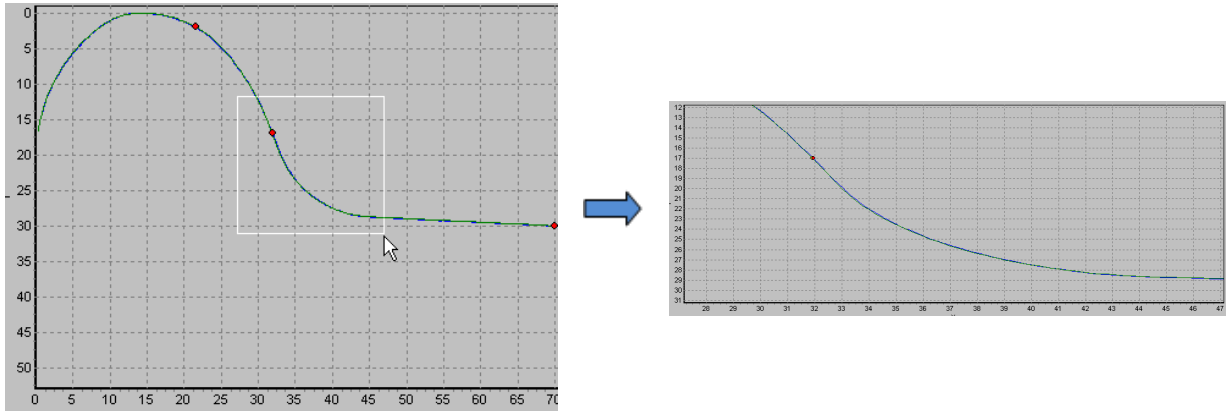

24. Implementation of minimum wheel truing function

Select **Tools > Analysis of profiles**. The analysis of wheel profiles allows to choose such a type of the profile from the reference profiles, for which the total truing depth of two wheels would be minimal.

In the first table of profiles, select the first required profile of the wheelset (left wheel); in the second table of profiles, select the second required profile of the wheelset (right wheel).

The program allows to perform the automatic analysis by all the reference profiles, which stored in the database, or by the selected profile only.

- Automatic analysis

Tick the box and click the **Analysis** button. Profiles in the table of references must not be marked.

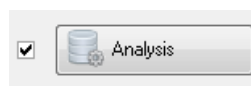

- Analysis by the selected profile

Select the reference profile for analysis and click the **Analysis** button.

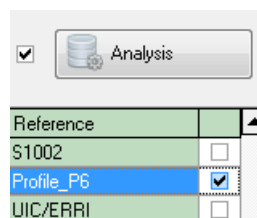

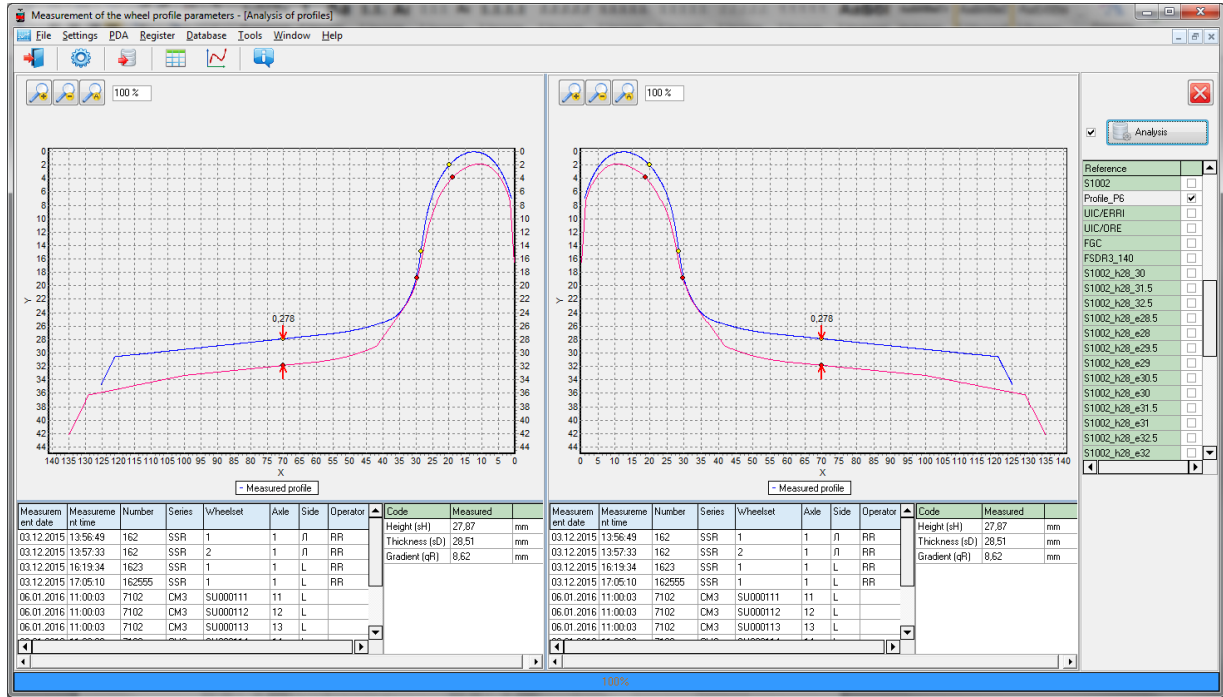

To know the wheel cutting depth in a certain point, put the cursor to any profile, and when a cross-like (+) mouse cursor appears press the left mouse key. The resulting screen will show the value of difference between profiles along X- and Y-axes, as shown by arrows. To remove size indication from the screen, put cursor to any of the profiles and press the right mouse key.

25. Scanning and editing of data

25.1. Scanning and filtering of data

Select **Database > Table** in the menu or click the **Table** button - . The form with results will be as follows:

Measurement time	Measurement date	Wheelset	Number	Series	Axle	Operator	Mileage	Height (hH) (Left)	Height (hH) (Right)	Thickness (tD) (Left)	Thickness (tD) (Right)	Gradient (qR) (Left)	Gradient (qR) (Right)	Diameter (D) (Left)	Diameter (D) (Right)
13:56:49	03.12.2015	1	162	SSR	1	RR	278	27.87		28.51		8.62			
13:57:33	03.12.2015	2	162	SSR	1	RR	278	18.76		24.46		4.95			
16:19:34	03.12.2015	1	1623	SSR	1	RR	278	27.83		29.75		8.61			
17:05:10	03.12.2015	1	162555	SSR	1	RR	278	27.70		31.96		8.57			
11:00:03	06.01.2016	SU000111	7102	CM3	11		1111	29.87		31.89		10.33			
11:00:03	06.01.2016	SU000112	7102	CM3	12		1112	29.88	29.87	31.91	31.89	10.34	10.34		
11:00:03	06.01.2016	SU000113	7102	CM3	13		1113	29.88	29.88	31.89	31.89	10.36	10.33		
11:00:03	06.01.2016	SU000114	7102	CM3	14		1114	29.88	29.88	31.90	31.90	10.34	10.33		

- **Hide/show the field**

The table displays the identification and geometric parameters of the wheelset, which are selected for displaying in the parameters settings (see par. [21.1.1](#) and [21.1.2](#)).

• **Sorting of data**

To sort data for any of the fields, click the left mouse key on the header of the field column:

Measurement date	Measurement time	Wheelset
03.12.2015	13:56:49	1
03.12.2015	13:57:33	2
03.12.2015	16:19:34	1
03.12.2015	17:05:10	1



Measurement date	Measurement time	Wheelset
03.12.2015	13:56:49	1
03.12.2015	16:19:34	1
03.12.2015	17:05:10	1
03.12.2015	13:57:33	2

115

To cancel data sorting, press the **Ctrl** key and click the left mouse key on the header of the field column.

• **Filtering of data**

In order to filter data in any of the fields, click the left mouse key on the header of the field grouping, and select the required value in the emerged drop-down list:

Measurement	Measurement time	Wheelset
(All)	13:56:49	1
(Custom...)	13:57:33	2
<input type="checkbox"/> 03.12.2015	16:19:34	1
<input type="checkbox"/> 06.01.2016	17:05:10	1
06.01.2016	11:00:03	SU000111
06.01.2016	11:00:03	SU000112
06.01.2016	11:00:03	SU000113
06.01.2016	11:00:03	SU000114



Measurement date	Measurement time	Wheelset
06.01.2016	11:00:03	SU000111
06.01.2016	11:00:03	SU000112
06.01.2016	11:00:03	SU000113
06.01.2016	11:00:03	SU000114

To cancel filtering, all steps should be taken in the reverse order.

• **Data grouping**

To group data for any of the fields, click the left mouse key on the header of the field column, and, with the mouse key pressed, drag it onto the table header:

Measurement date	Measurement time	Wheelset
06.01.2016	11:00:03	SU000111
06.01.2016	11:00:03	SU000112
06.01.2016	11:00:03	SU000113
06.01.2016	11:00:03	SU000114



Measurement date		
Measurement date	Measurement time	Wheelset
+ Measurement date : 06.01.2016		
+ Measurement date : 03.12.2015		

• **Changing of the field position order**







To change the field position, click the left mouse key on the header of the field column and, with the mouse key pressed, drag it to the required position:

Measurement date	Measurement time	Measurement	Wheelset
03.12.2015	13:56:49	1	
03.12.2015	13:57:33	2	
03.12.2015	16:19:34	1	
03.12.2015	17:05:10	1	

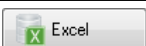

Measurement time	Measurement date	Wheelset
13:56:49	03.12.2015	1
13:57:33	03.12.2015	2
16:19:34	03.12.2015	1
17:05:10	03.12.2015	1

Buttons:

 Add	Add the wheel pair
 Delete	Delete the selected wheel pair
 Delete all	Delete all wheel pairs
 Edit	Edit the selected wheel pair
 Excel	Export the coordinates of wheel pairs to the Excel format
 Report	Report preparation

25.2. Editing data

You can edit, add and remove data in/from the database.

- **Editing data**

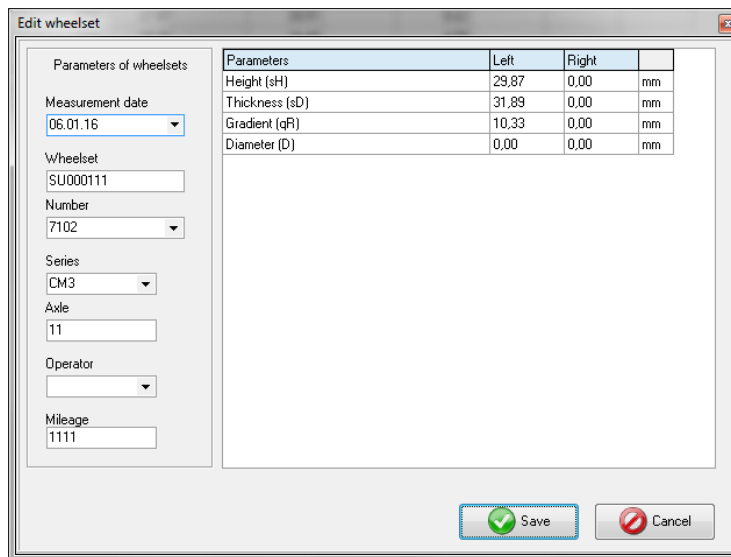

To edit the current entry, click the **Edit** button and input/change required values of parameters. After the editing is complete, click the **Save** button.

- **Adding data**

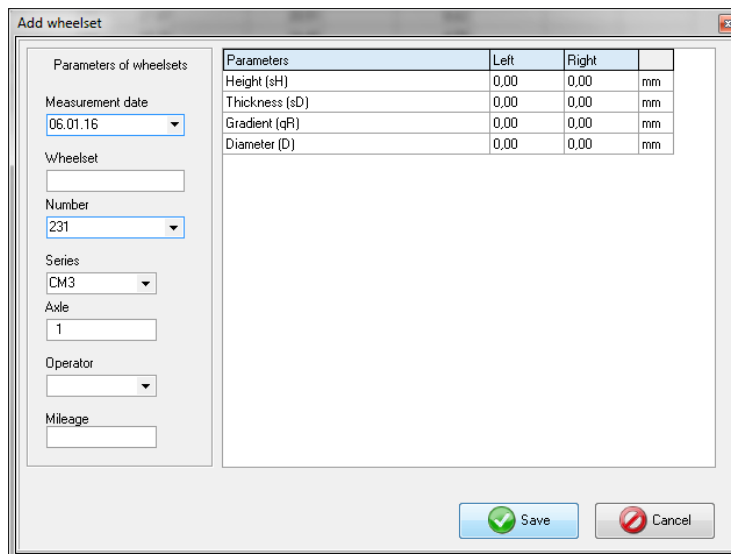

To add a new data entry, click the **Add** button and type required parameter values. After the editing is complete, click the **Save** button.

- **Deleting data**

To delete the current entry, click the **Delete** button and confirm the deletion.

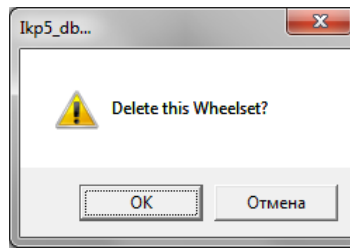

- **Deleting all selected data**

If it is necessary to delete not only one entry but several entries combined by some condition, filter the data according to the corresponding attribute (see par. [25.1](#)), click the **Delete all** button and confirm the deletion.

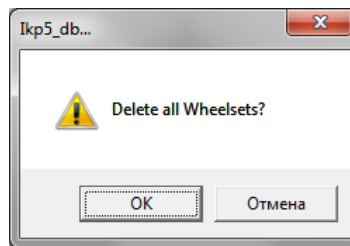

25.3. Report preparation

When staying in the mode of scanning and editing data, the user can prepare reports in **Excel**, **RTF**, **PDF** formats, or print out reports. When preparing the report, the sorting used at the moment is taken into account.

To generate a report, click the **Report** button. The program will offer to select the following options:

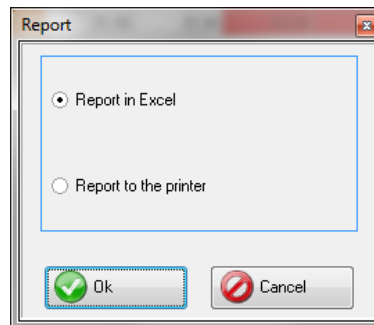

25.3.1. Excel-format report

To prepare a report in Excel format, select **Report in Excel** and click **OK**.

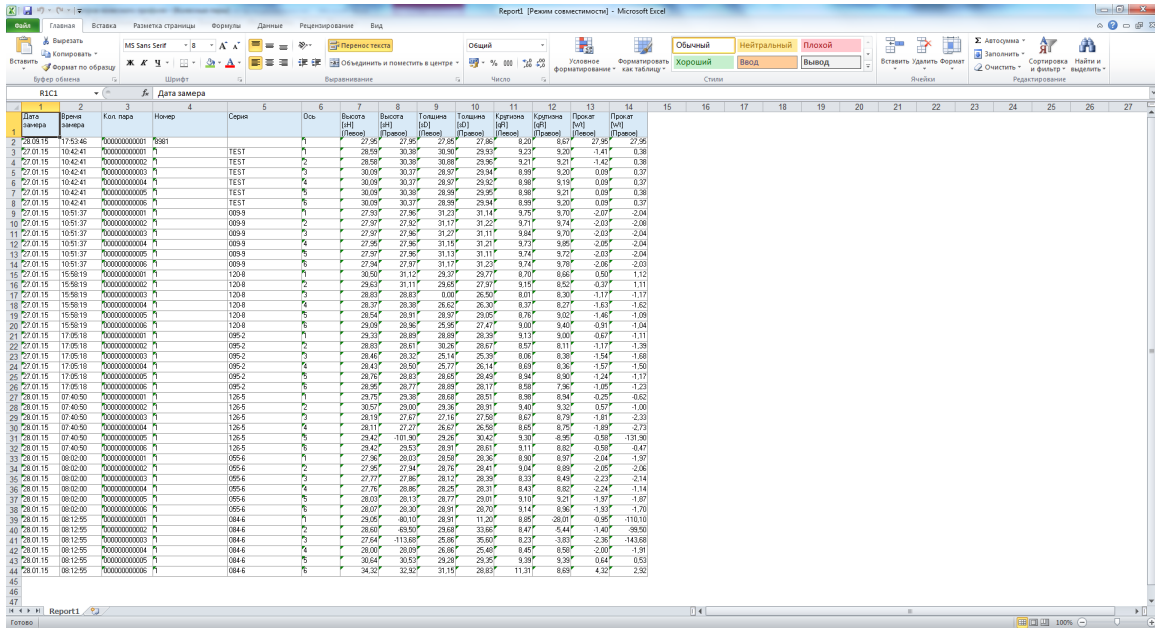

118

25.3.2. Report for printout

To prepare the report for printout, select **Report for printout** and click **OK**. Data will be presented in the form of report ready for printout.

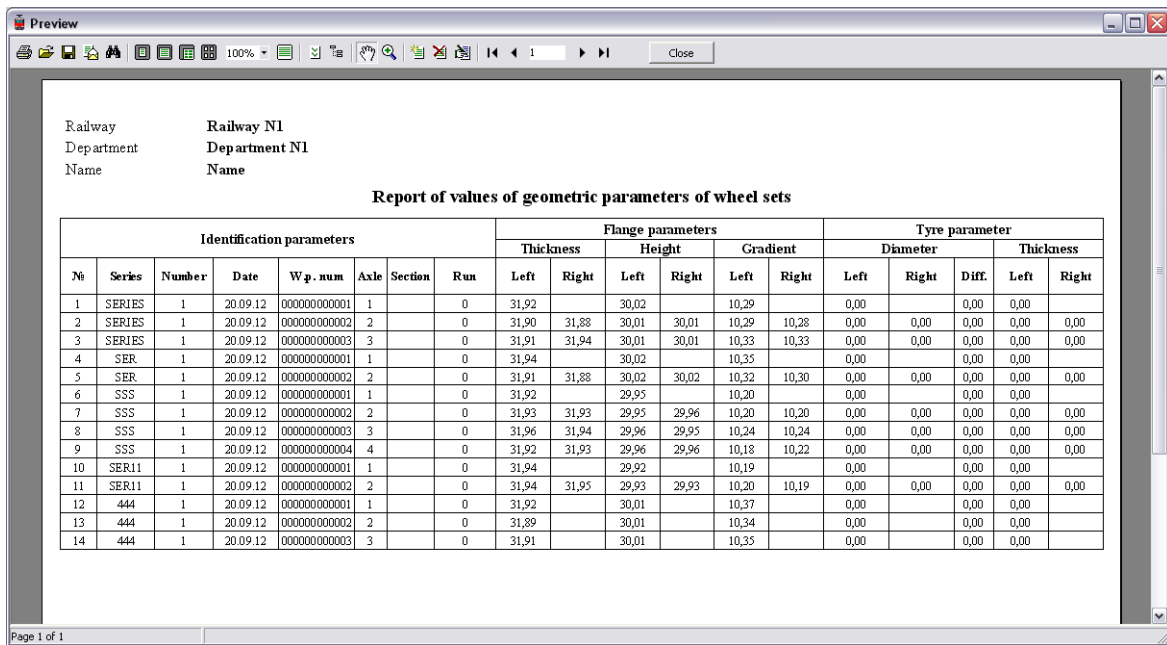

The top toolbar contains the following buttons for operating with reports:

- To printout the report, click
- To save in PDF format, click
- To save in Excel, RTF or PDF, click and select the format you need:

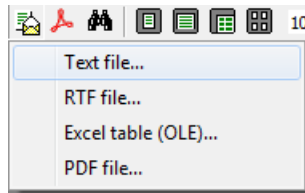

26. Taking measurements under PC control (without PDA)

The laser scanning module (RF505) can work under direct control of PC without PDA. To work under direct control of PC, it is necessary to select **File > Device > RF505-Profilometer** in the main menu.

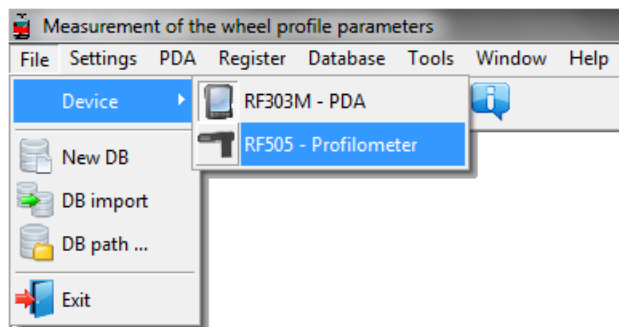
119

In the main menu of the program, the **PDA** tab will be replaced with the **Profilometer** tab.

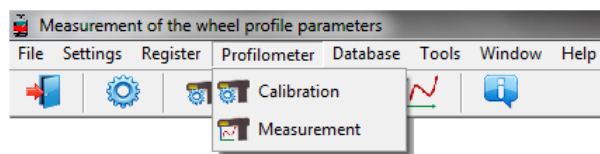

The menu contains two available items:

- Calibration
- Measurement

Before you start working with the profilometer, it is necessary to set the COM port for Bluetooth connection between the laser scanning module and PDA. The procedure is described in the User's manual that comes with the Bluetooth adapter.

26.1. Calibration

To calibrate the device, select **Profilometer > Calibration**, or click .

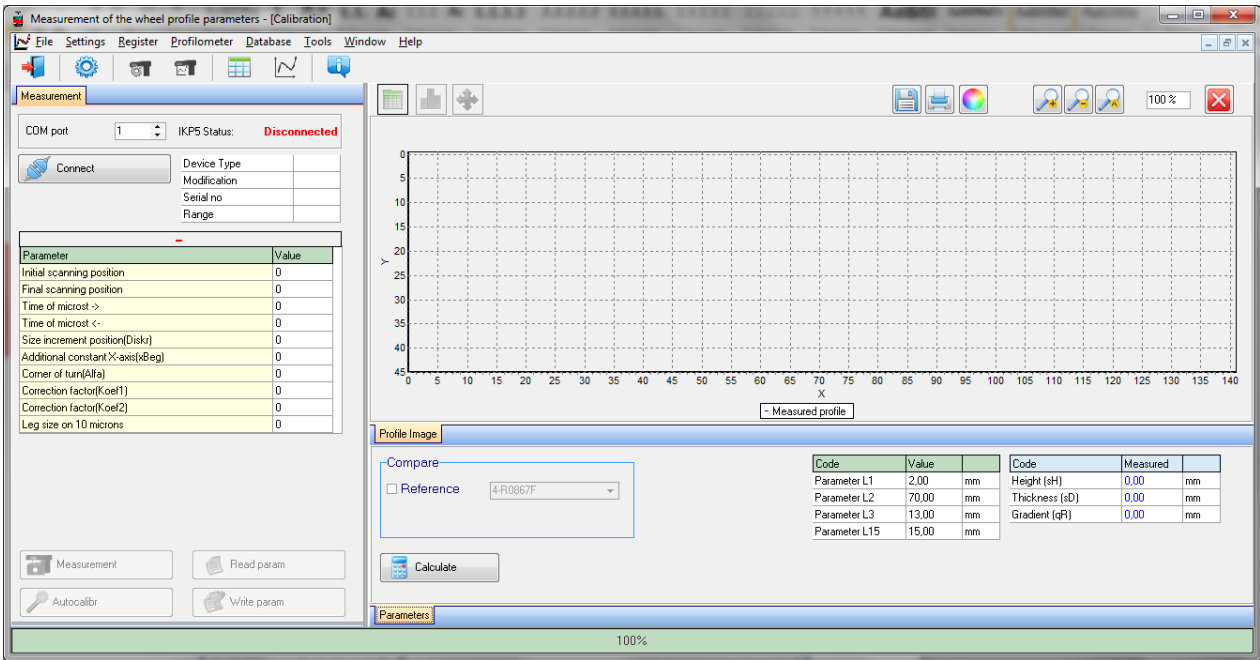

26.1.1. Bluetooth connection

Select the COM port and click the **Connect** button.

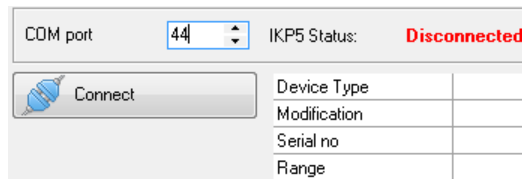

 For more information, refer to par. [29](#).



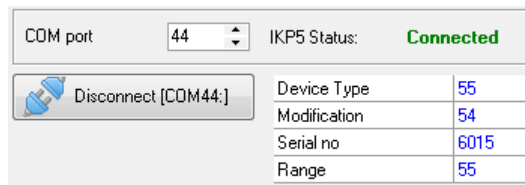

If the connection is successful, the device will be identified, and calibration parameters will be obtained. The status will be changed to **Connected**.



The table of calibration parameters:

Parameter	Value
Initial scanning position	30
Final scanning position	2860
Time of microst ->	6
Time of microst <-	5
Size increment position(Diskr)	4935
Additional constant X-axis(xBeg)	5330
Corner of turn(Alfa)	63
Correction factor(Koef1)	0
Correction factor(Koef2)	0
Leg size on 10 microns	0

Buttons:

 Measurement	Measurement.
 Read param	Reading calibration parameters.
 Write param	Writing calibration parameters.
 Autocalibr	Automatic setting of calibration parameters.

 The **Auto calibration** button will be active, if at least one measurement of the profile is performed and the reference profile is selected.

26.1.2. Calibration of the profilometer

- Place the profilometer on the calibration block.
- Select the reference profile from the list (**Compare > Reference**).
- Perform the measurement (the **Measurement** button)
- Perform the calibration (the **Autocalibr** button).
- Save calibration parameters (the **Write param.** button).

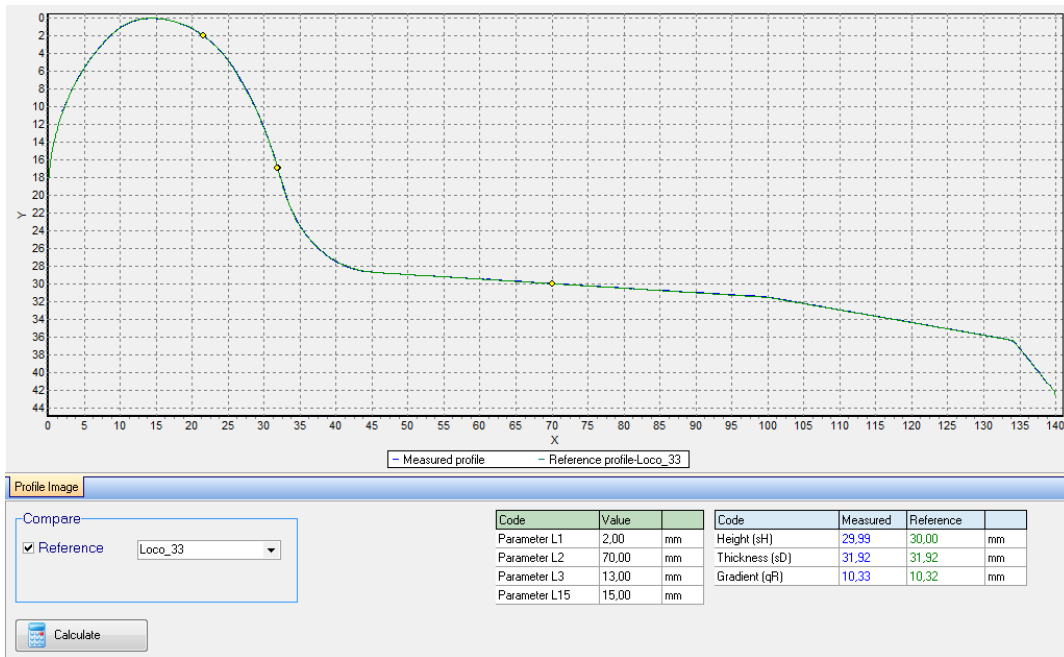

Calibration parameters can be set manually. To do it, click left mouse key on the field of the required parameter value, and enter the new one.

 **Attention!** Writing incorrect values of some parameters can lead to the incorrect work of the device.

Buttons functions, work with profiles and calculation of required parameters are described in par. [21](#).

26.2. Measurement by using PC

To measure, select **Profilometer > Measurement**, or click the button .

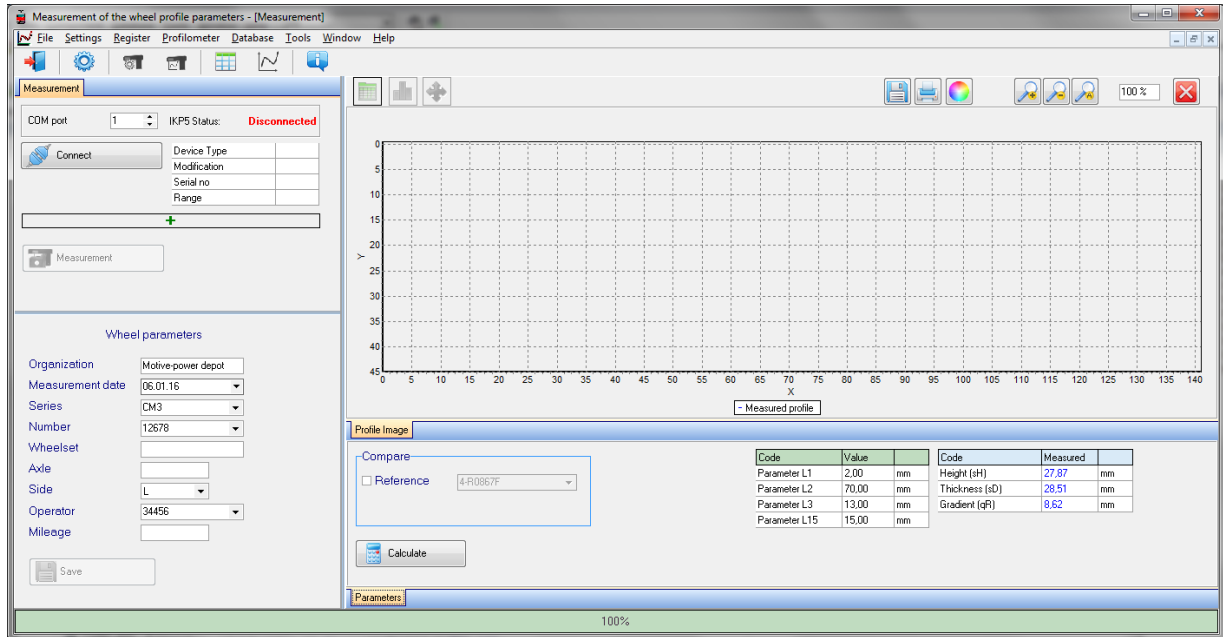

When the Bluetooth-connection is established (see par. [26.1.1](#)), the **Measurement** button is active.

26.2.1. Saving of data

- Place the profilometer on the wheel.
- Perform the measurement (the **Measurement** button).
- Enter the identification parameters of the wheelset.

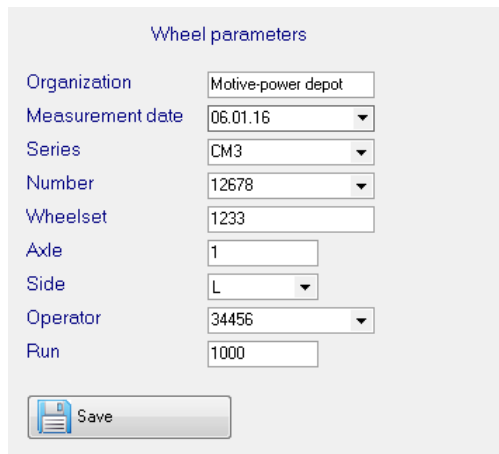

- To save results, click **Save**.
- The measured profile will be saved to the database.

Buttons functions, work with profiles and calculation of required parameters are described in par. [21](#).

27. Annex 1. Charging procedure

- Switch off the PDA (laser module).
- Connect the charging device to PDA (laser module).
- Connect the charging device to 220V AC.
- Full-charge indication of laser module - green LED is lit.
- Disconnect the charging device from 220V AC.
- Disconnect the charging device from PDA (laser module).



Attention! Please follow the sequence of these points.

123

28. Annex 2. Program for creating the measurement schemes

To create the measurement schemes, use the special program **SchemeBuilder.exe**. When the program is started, the main window appears on the screen:

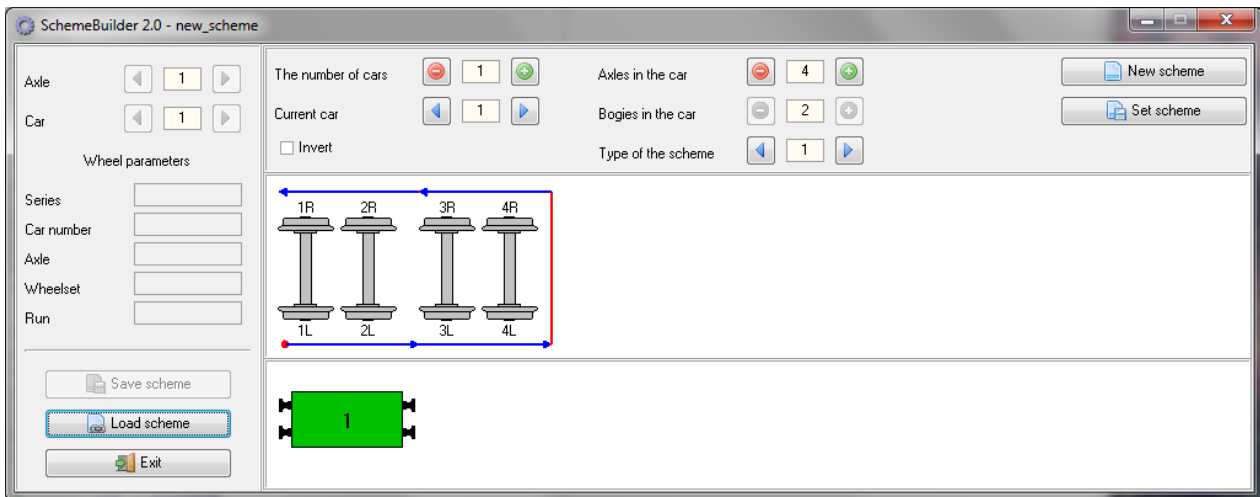

To form the scheme:

- Enter the number of cars
- Enter the number of axles in every car
- If the measurement of the car is performed in the reverse order, tick the box Invert
- Select the type of the scheme
- Click the button to accept
- Next, enter parameters of all wheelsets sequentially for each car

Wheel parameters	
Series	Series
Car number	1234
Axle	1
Wheelset	11
Run	

- The fields **Axle** and **Car** are used to navigate through the scheme



- Click the **Save scheme** button 
- Enter the name of the scheme in the dialog box window

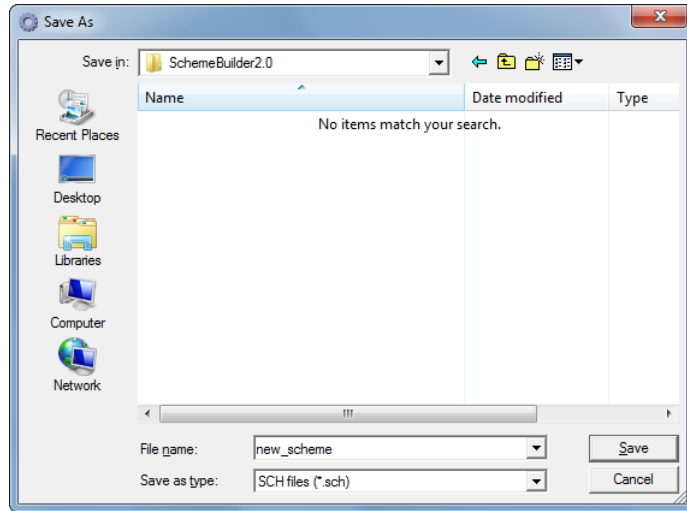

The program allows to edit the existing scheme. To edit the scheme, click the **Load scheme** button and select the *.SCH file. After loading, you can edit and save the wheelset parameters.

To transfer the scheme file to PDA, use the procedure described in par. [22.1.5](#).

Clarification. The measurement scheme is a text file with extension **.sch**. User can create and edit such file by using any text processor.

Example:

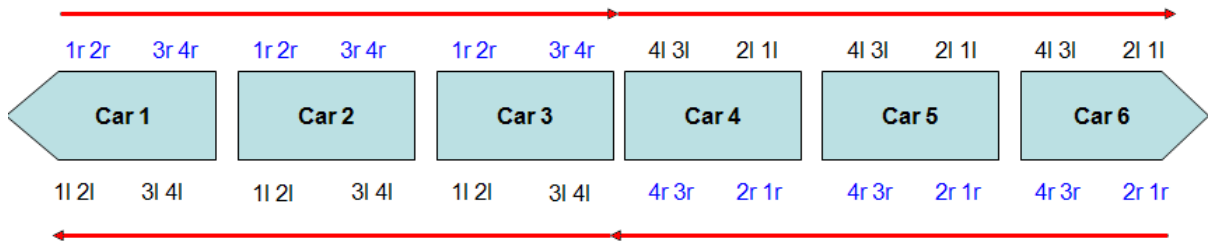

Scheme_EXAMPLE

```
{
1d-SM3|7102|1|11|SU11|111|1r|11|SU11|111|2|12|SU12|112|2r|12|SU12|112|3|13|SU13|113|3r|13|SU13|113|4|14|SU14|114|4r|14|SU14|114|
2d-SM3|7202|1|121|SU21|211|1r|21|SU21|211|2|22|SU22|212|2r|22|SU22|212|3|23|SU23|213|3r|23|SU23|213|4|24|SU24|214|4r|24|SU24|214|
3d-SM3|7302|1|131|SU31|311|1r|31|SU31|311|2|32|SU32|312|2r|32|SU32|312|3|33|SU33|313|3r|33|SU33|313|4|34|SU34|314|4r|34|SU34|314|
4i-SM3|7402|4r|44|SU044|414|4l|44|SU44|414|3r|43|SU43|413|3l|43|SU43|413|2r|42|SU42|412|2l|42|SU42|412|1r|41|SU41|411|1l|41|SU41|411|
5i-SM3|7502|4r|54|SU54|514|4l|54|SU54|514|3r|53|SU53|513|3l|53|SU53|513|2r|52|SU52|512|2l|52|SU52|512|1r|51|SU51|511|1l|51|SU51|511|
6i-SM3|7602|4r|64|SU064|614|4l|64|SU64|614|3r|63|SU63|613|3l|63|SU63|613|2r|62|SU62|612|2l|62|SU62|612|1r|61|SU61|611|1l|61|SU61|611|
}
```

Where:

- 1d – coaches arranged in direct order (1 – sequence number)
- 1i – coached arranged in the reverse order (1 – sequence order)
- SM3 – coach series
- 7102 -number
- 1l – sequence number of wheel pair and the side (l- left/r-right)
- 11 – axle number
- SU11 – name of wheel set
- 111 – running distance of wheel set

29. Annex 3. Testing and calibration

We can supply the profilometer complete with an RF505.11 calibration-wheel simulation unit (Fig. 1A) and **RF505Calibr** calibration program that are designed for periodic testing and self-calibration of the profilometer.

Instead of the calibration unit use can be made of the wheel with known profile entered to the database (see par. [21.3.6](#)).

Before start the testing and calibration process, it is necessary to set the COM-port for Bluetooth-connection between the laser scanning module and PDA. The procedure is described in the user manual that comes with the Bluetooth-adaptor.

When you add the device, Windows will ask for the pairing code. The pairing code for each device consists of 4 symbols and is formed according to a serial number. For example, if a serial number is 04217, then a code will be 0427; if a serial number is 01318, then a code will be 0138, etc.

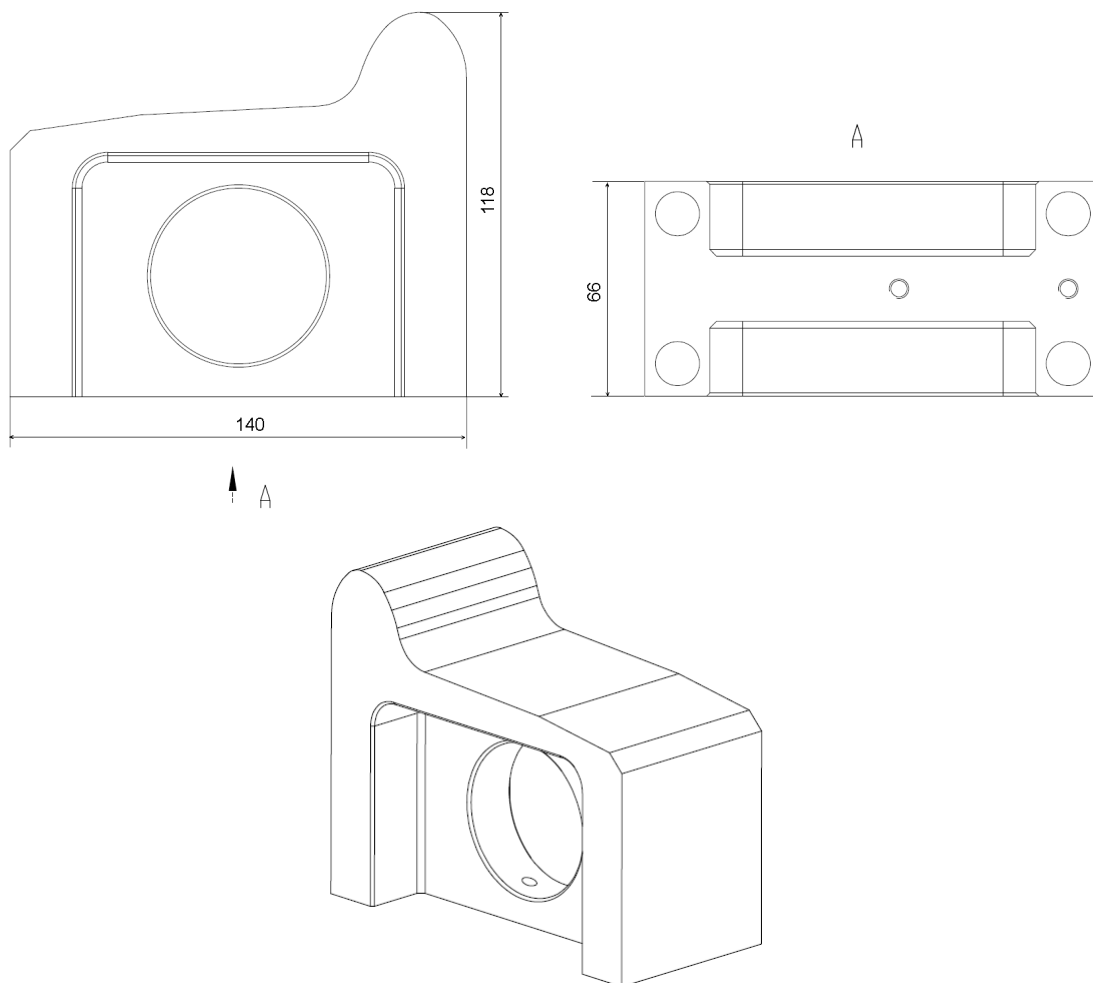
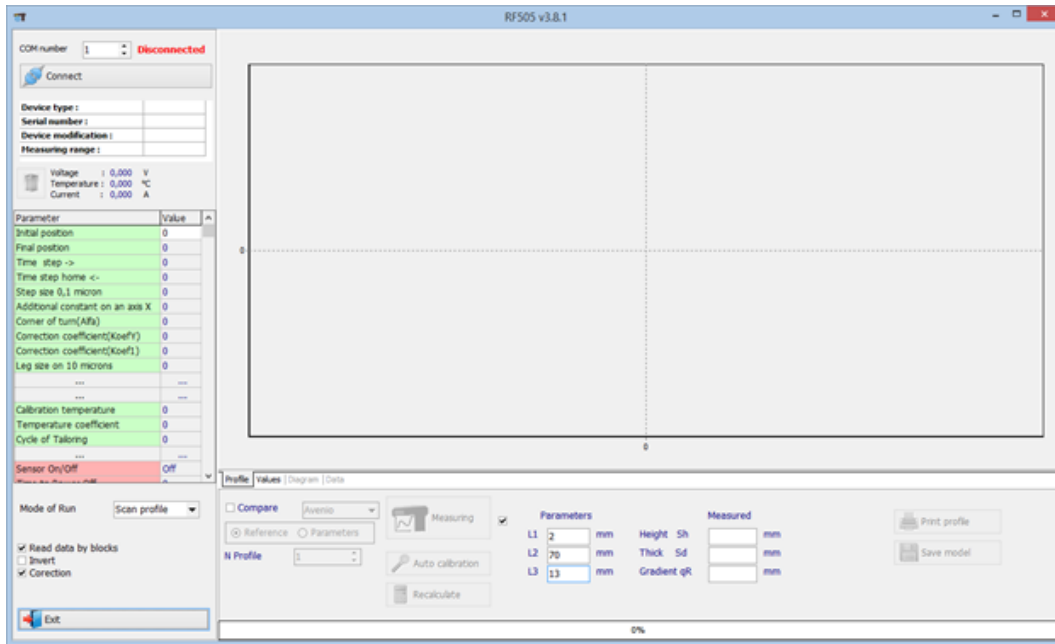

Figure 1A

29.1. Preparation for testing/calibration

- Install the **RF505** program on the PC.
- Install Bluetooth-connection between the scanning module and PC.
- Place the profilometer on the calibration unit.
- Run **RF505** program.



- To install Bluetooth-connection, select the required port.

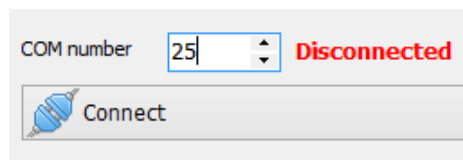

The device will be identified, and calibration parameters will be read.

- To perform the measurement, pass to the **Profile** tab and click **Measurement**. After measuring, the display will show the measured profile and the calculated geometric parameters of the profile: Height (Sh), Thickness (Sd), Slope (qR). Parameters are measured at support points L1, L2, L3.

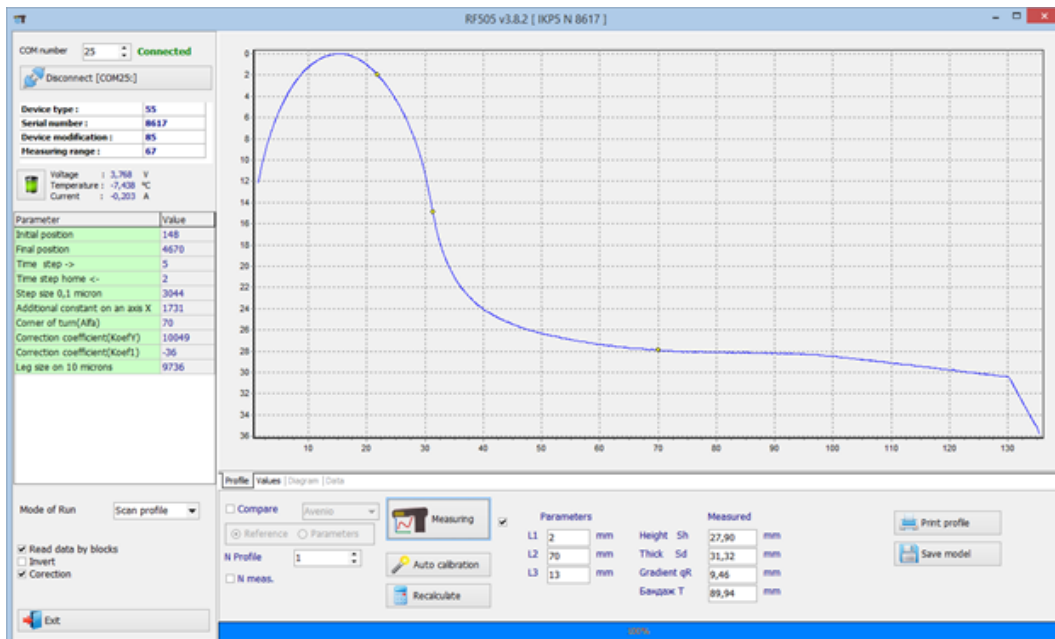

- To compare with the reference, tick the **Compare** box and select the required reference value profile in the **Reference** drop-down list.

29.2. Testing

To carry out automatic testing, do the following steps:

- Tick the **N meas.** box (number of measurements).
- Specify the number of measurements (5-10).
- Click the **Measuring** button.

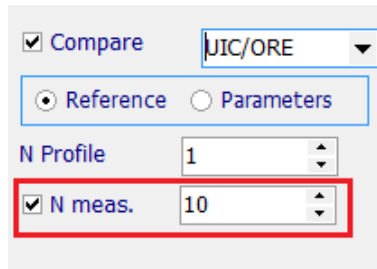

The scanning module will make the specified number of measurements whose results will be entered to the table (the **Data** tab). The first three columns will present measured values of height (Sh), thickness (Sd), and flange slope (qR), while the other three columns will present deviations of the measured values from the reference values (d_Sh, d_Sd, d_qR).

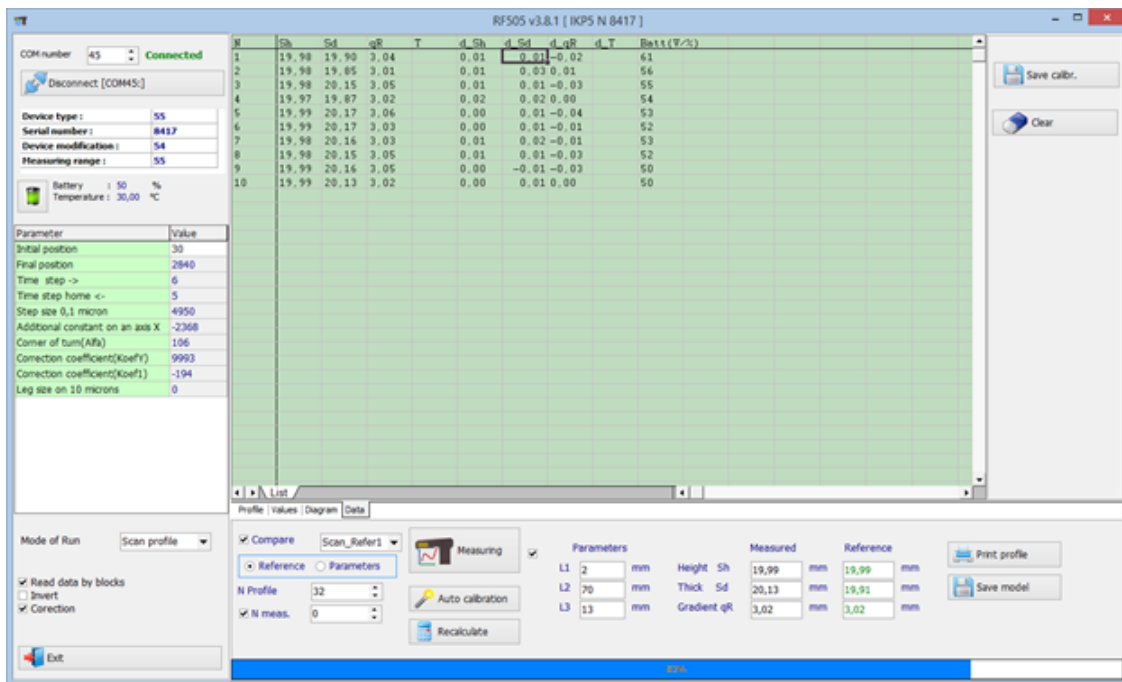

The **Diagram** tab is intended for displaying the diagram of values/deviations of the measured profile from the selected reference. Deviation of the flange height and thickness from the reference values must not be more than 0.1 mm. If deviations exceed the permissible value, it is necessary to perform calibration of the scanning module.

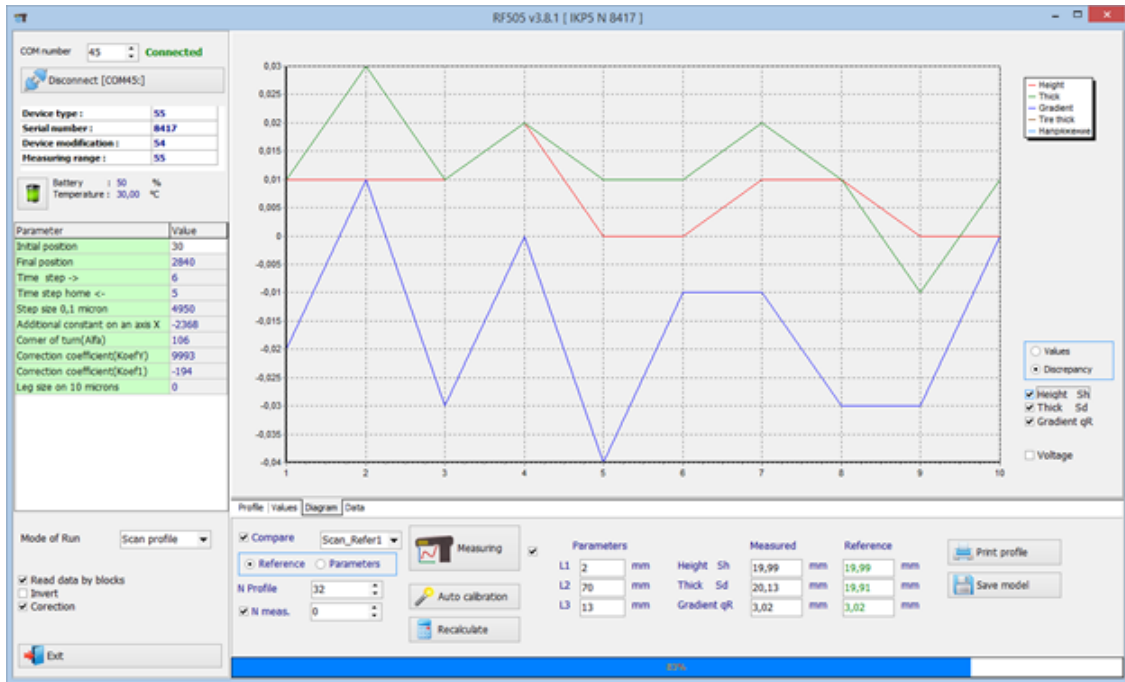

29.3. Calibration

To carry out automatic calibration, do the following steps:

- Select the reference profile from the list.

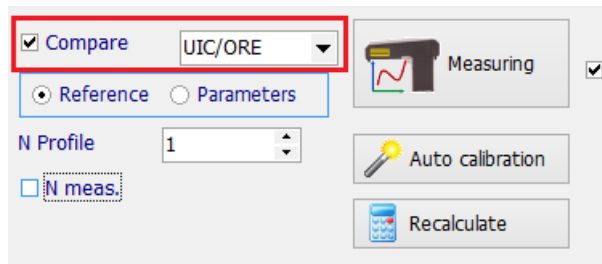

- Perform the measurement (the **Measuring** button).
- Perform the calibration (the **Auto calibration** button).
- When scanning is complete, perform the testing procedure in accordance with [29.2](#). In case of positive result, save parameters:
 - Right-click on the table and select **Write**.
 - Right-click on the table and select **Write to FLASH**.

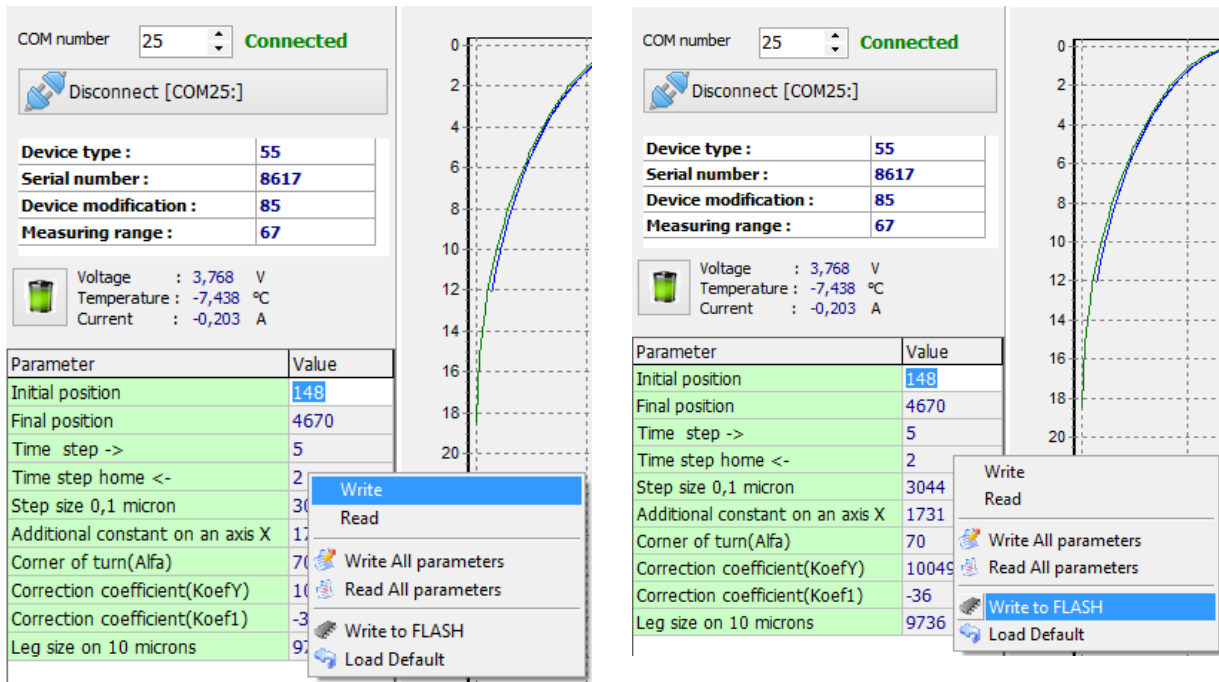

29.4. Restoring the factory settings

If parameters have incorrect values (negative or zero), it is necessary to restore the factory settings by pressing the **Load Default** button. After that, recalibrate the profilometer.

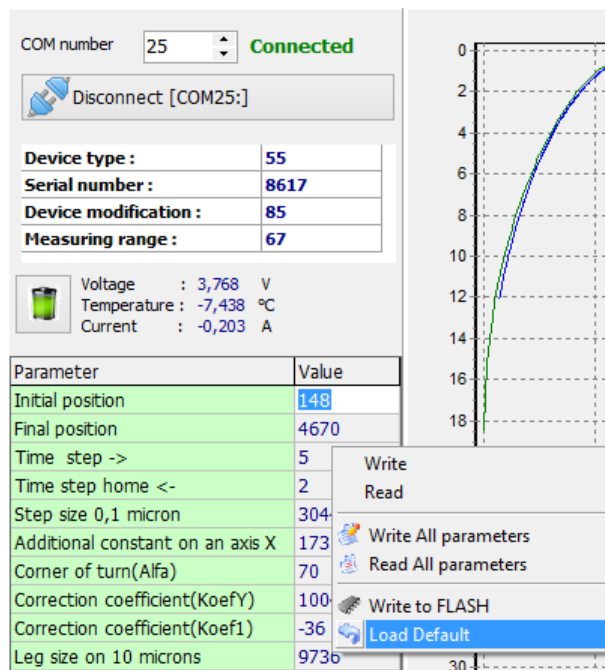

30. Annex 4. Software application for working with the "A.U.R.A. Wheel" system

When working with the **A.U.R.A. Wheel** system from NEM Solutions, the laser scanning module is controlled by the special software application installed on a tablet computer.

30.1. Installation

To install the software, select and run the **lkp5_Tablet.exe** file. Follow the guidelines in dialog boxes of the Installation Wizard. By default, the software will be installed in the following directory – **C:\Program Files (x86)\Riftek, LLC\lkp5_Tablet**.

To start the program, press **Start > All programs > Riftek, LLC > lkp5_Tablet > lkp5_Tablet.exe**. The main window is shown below:

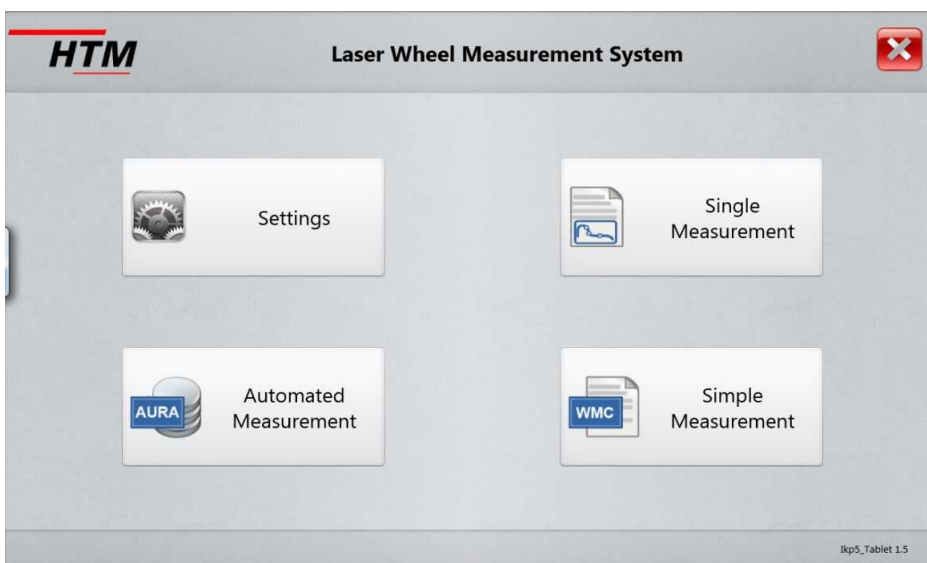

30.2. Settings

Before starting to work with the profilometer, it is necessary to configure parameters.

Press the **Settings** button. The program will require a password. When initially installed, the program accepts the following password: 1111. How to change the password, see Par. [30.2.3](#).

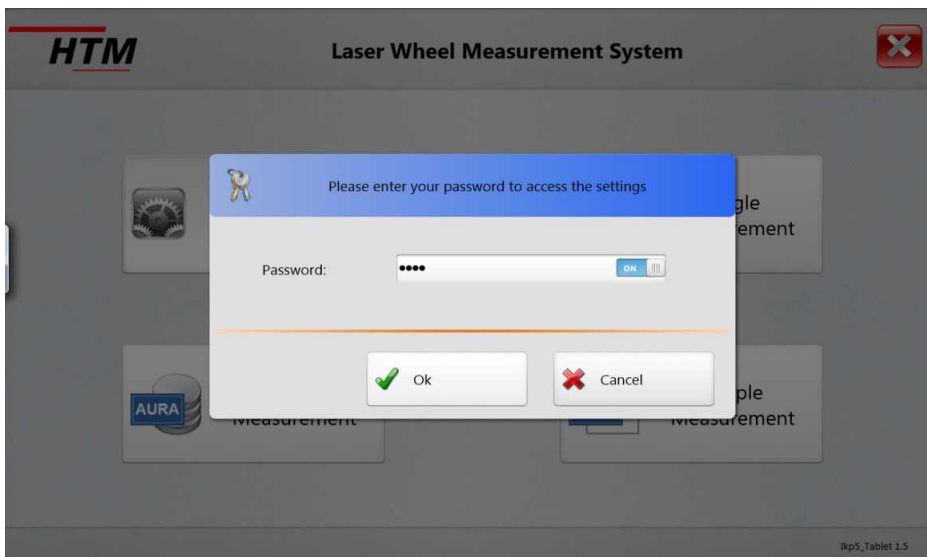

Enter the password and press **Ok**. The window of program settings will appear.

30.2.1. Language

The user can change the language, form his own language support files as well as change/edit the terminology used. To select the language, press **Language**, select the language support file, and press **Select**.

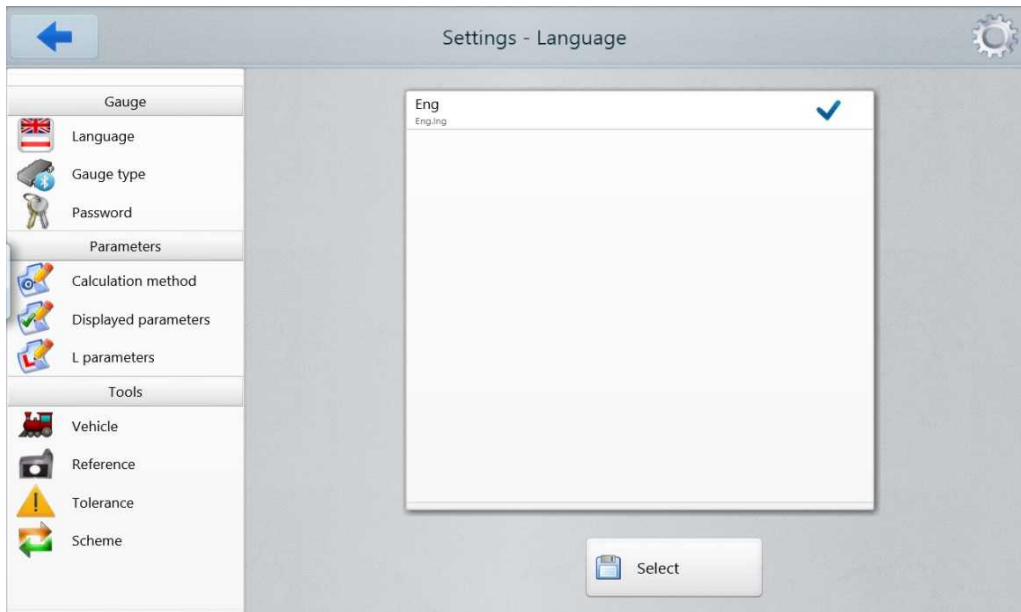

How to create the language support file, see Par. [21.2.4.1.](#)

30.2.2. Gauge type selection

The program allows to work with the following gauges: IKP, IDK, IMR. When selecting one of them, you will see a list of available devices (i.e. devices that have been connected earlier).

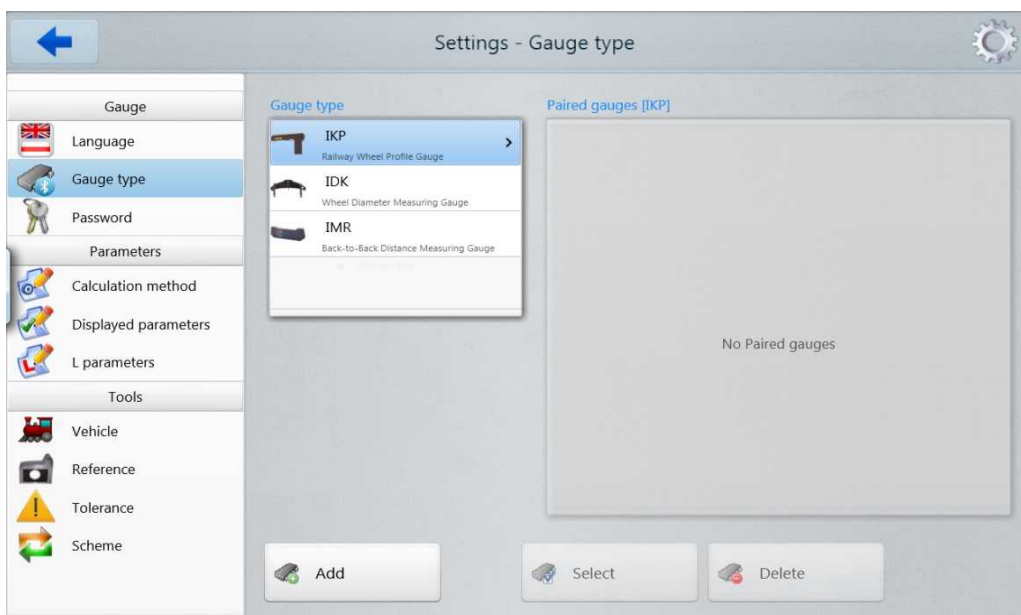

Select the gauge and press the **Select** button. Parameters of the selected gauge will be used to connect to it. If the device is not in the list, you can add it – press the **Add** button and start to search for Bluetooth devices.

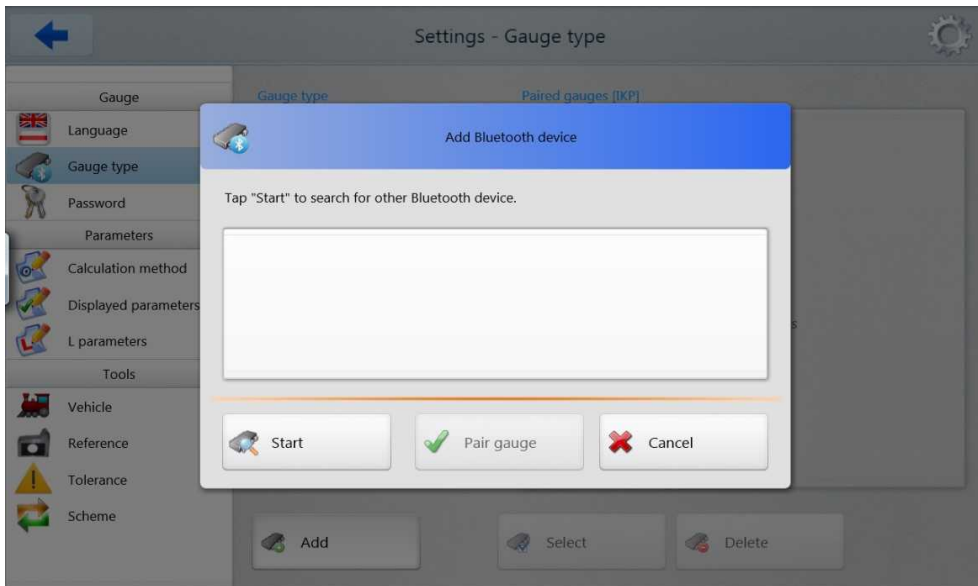

Press **Start** and wait for the search to complete.

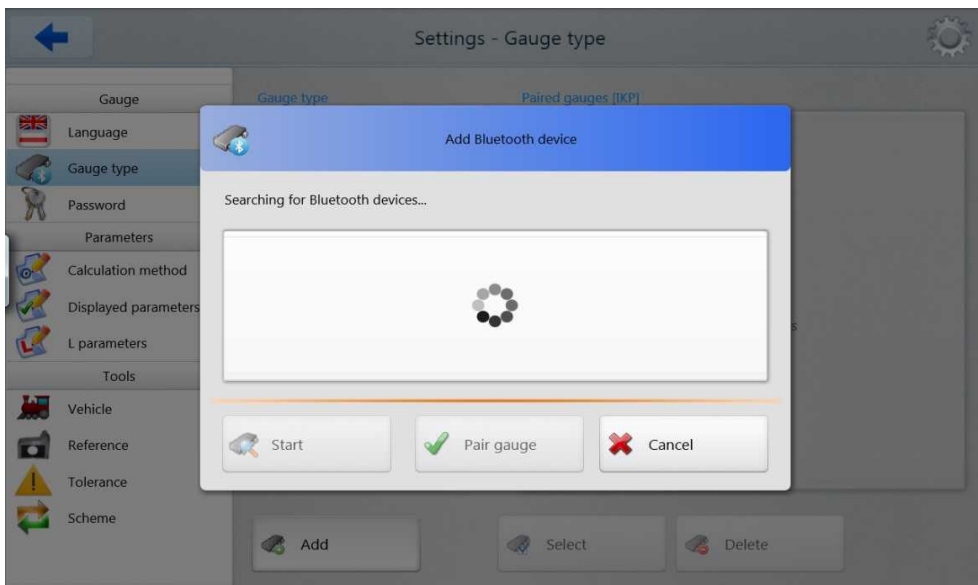

The detected devices with their serial numbers will appear:

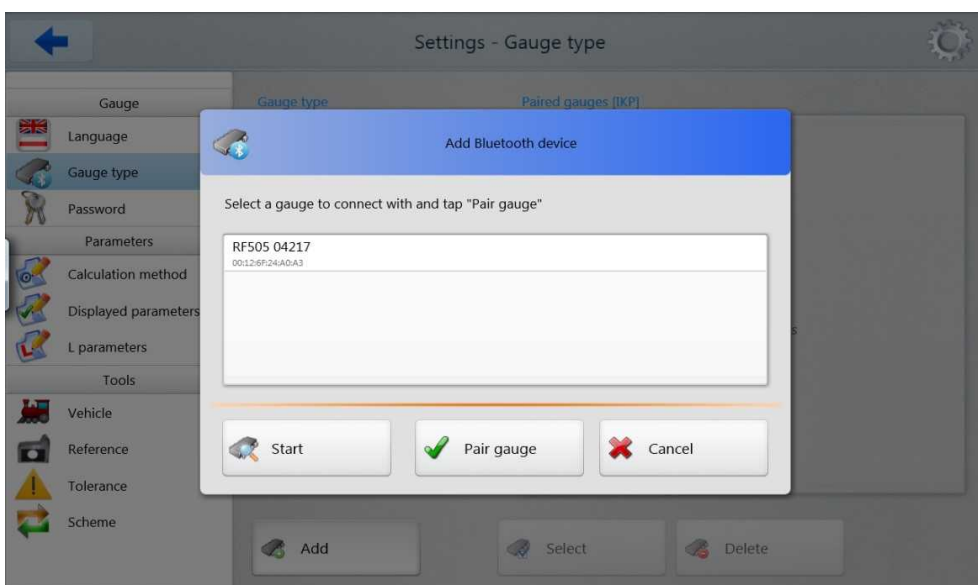

Select the device and press **Pair gauge** to include it in the list. Windows will report an attempt to add a new device, and request a pairing code.

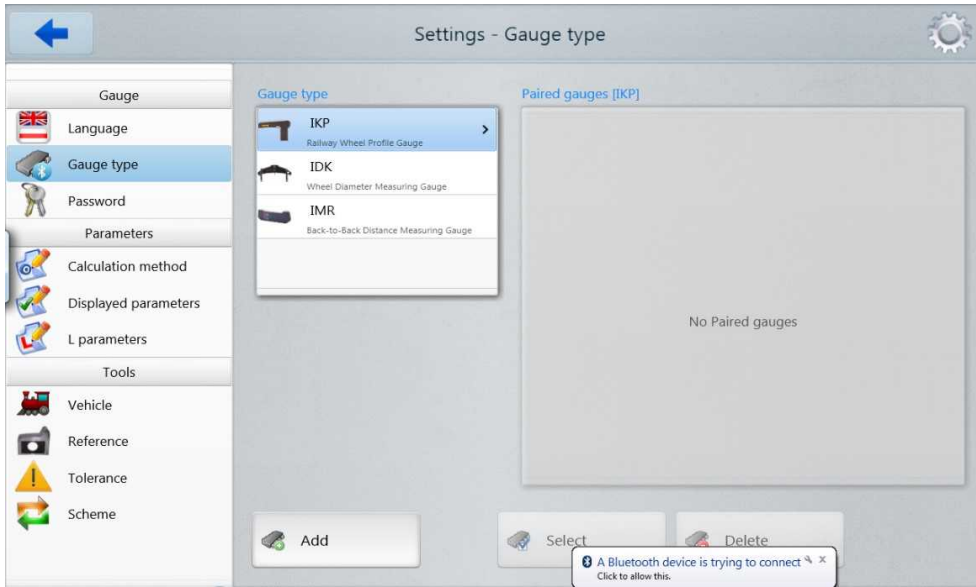

If the pairing code is correct and the device is successfully added, the system will display a message. The device installation may take some time. The pairing code for each device consists of 4 symbols and is formed according to a serial number. For example, if a serial number is 04217, then a code will be 0427; if a serial number is 01317, then a code will be 0137, etc.

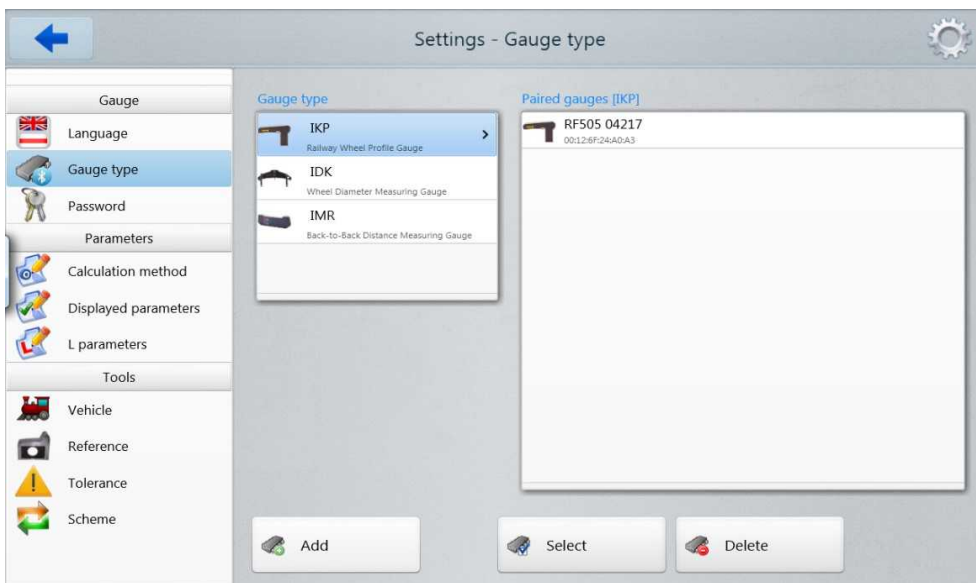
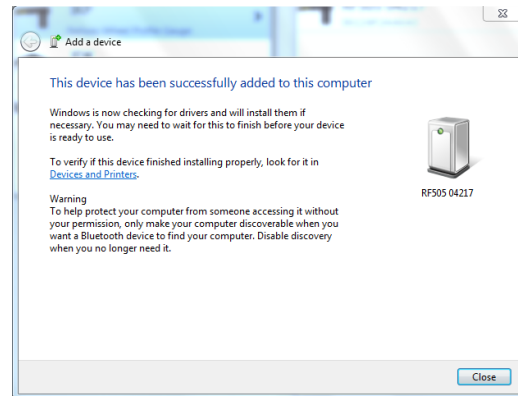
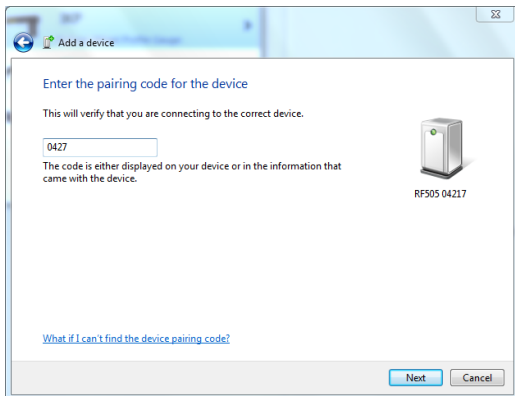

Select the device by pressing the **Select** button.

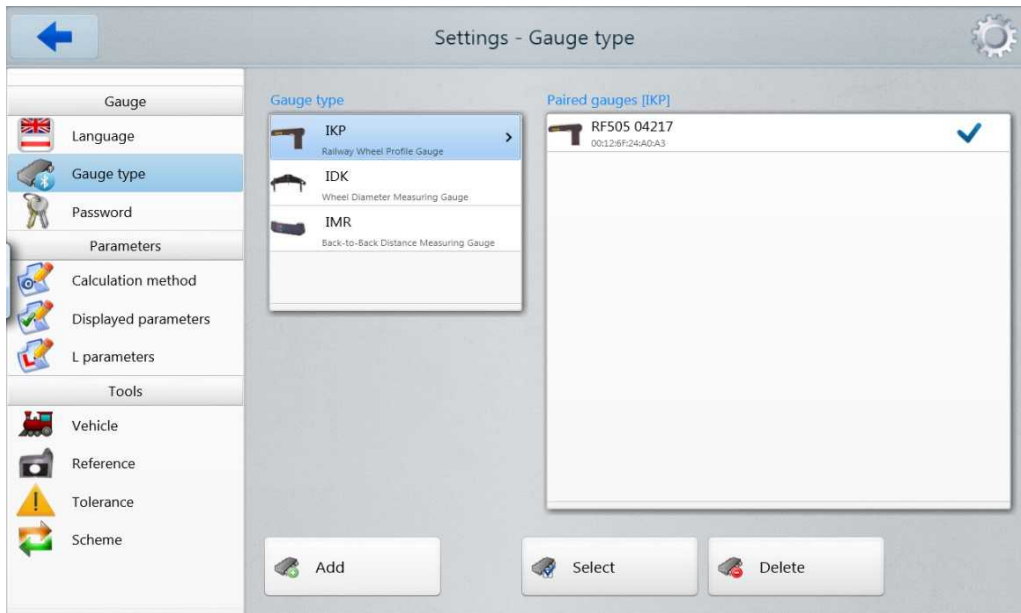

If you do not use the device anymore, you can delete it by pressing the **Delete** button. Similarly, you can add other gauges (IDK and IMR).

30.2.3. Password

To change the password, press **Password**.

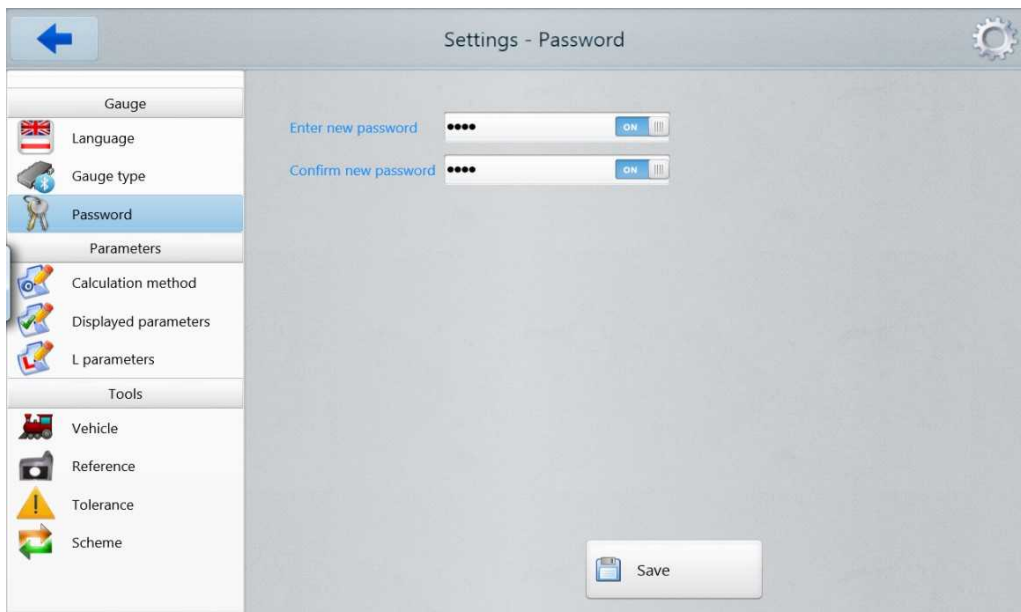

Enter a new password, confirm it, and press **Save**.

30.2.4. Calculation methods

Press **Calculation method**. On the screen:

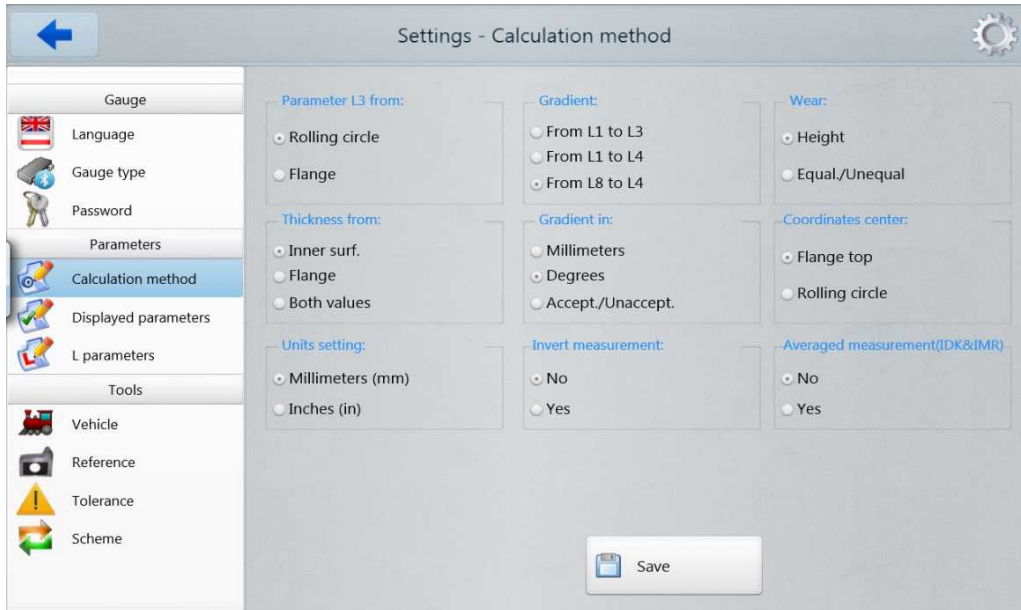

To save the changes, press **Save**.

30.2.5. Selection of displayed parameters

Press **Displayed parameters**. On the screen:

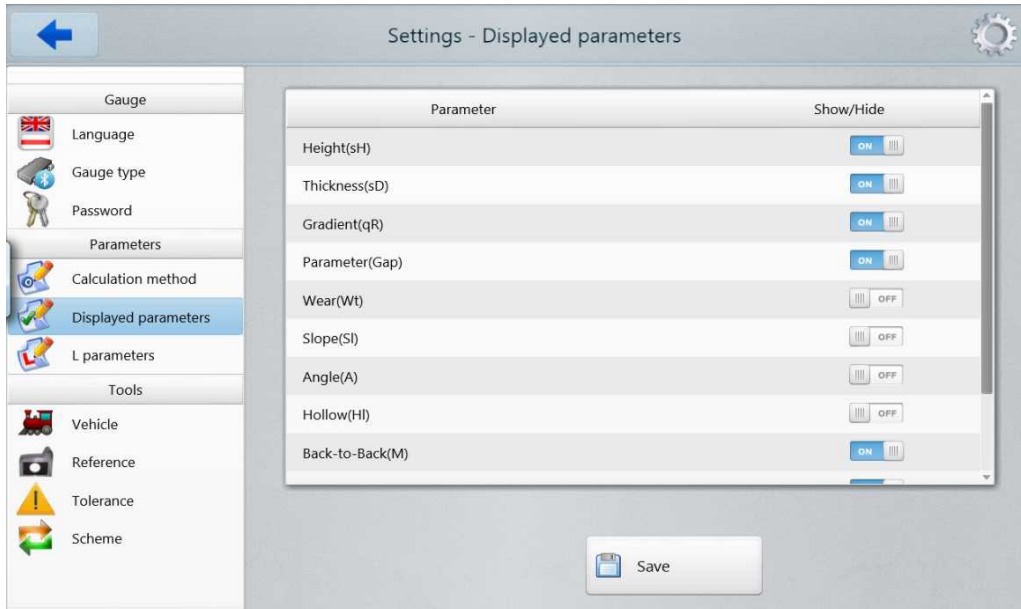

In order to select/deselect a parameter, set **ON/OFF** in the **Show/Hide** column. To save the changes, press **Save**.

30.2.6. L-parameters

Press **L parameters**. The table displays only those L-parameters that are necessary to calculate the selected geometrical parameters of the wheel.

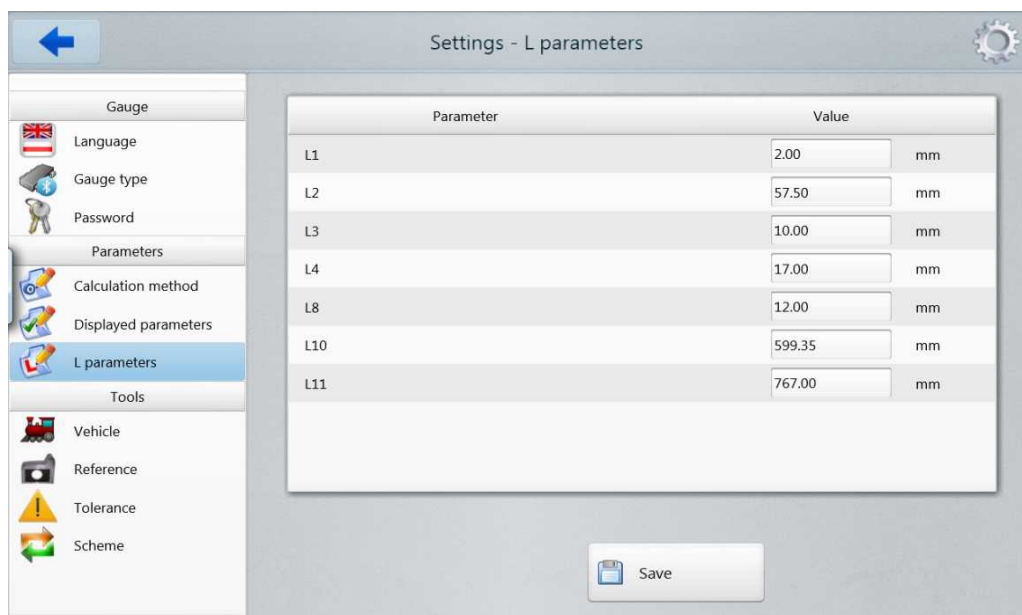

To save the changes, press **Save**.

30.2.6.1. Preset values

L-parameter	Default value	Assignment
L1	2 mm	Used for calculation of the flange slope (qR)
L2	70 mm	Defines position of the wheel rolling circle, and used for calculation: - flange height (sH) - flange thickness (sD) - flange slope (qR) - inclination angle (A) - wheel diameter (D) - rim thickness (T) - wear (Wt, Wf, Wr)
L3	13 mm	Used for calculation: - flange thickness (sD) - flange slope (qR) - wear (Wf)
L4	13 mm	An additional point for calculation of the flange slope (qR)
L5	10 mm	Used for calculation of an angular wear (Wr)
L6	70 mm	Used for calculation of slope of the rolling surface section (S1)
L7	105 mm	Used for calculation of slope of the rolling surface section (S2)
L8	10 mm	Used for measurement of the profile inclination angle at the required point (A)
L9	140 mm	Used for inverting the measurement direction (L9 – profile width)
L10	599,35 mm	Used for calculation of the profile diameter (D)
L11	767 mm	Used for calculation of the reference profile rim thickness (T)
L15	13 mm	Used for calculation of the flange thickness of tram wheels (sD15)

P7_1	50 mm	Used for calculation of the hollow (HI)
P7_2	105 mm	
P8_1	110 mm	
P8_2	130 mm	
D1	70 mm	Used for calculation of the hollow (HI)
D2	107,5 mm	

30.2.7. Reference profile selection and installation

The program allows to compare the scanned profile of the wheel with the reference profile. To select the reference profile, press **Reference**.

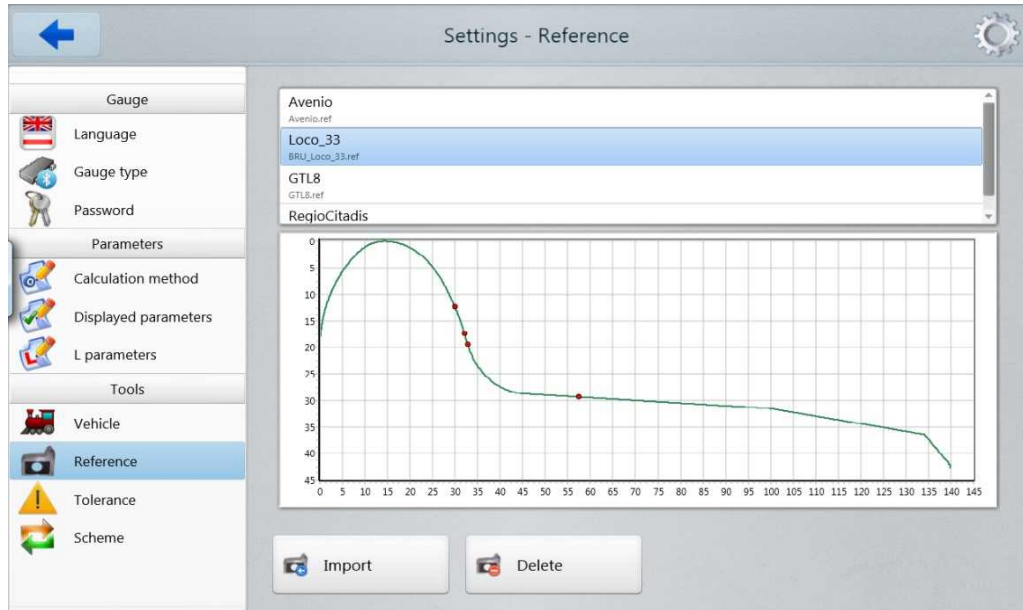

To delete the reference file, activate the line and press **Delete**.
To add the reference file, press **Import** and select the *.ref file.

30.2.7.1. Writing the reference profile to the database

Reference profiles are stored in the database as profile description files with the .ref extension. The software is supplied with several preset profiles.

If there is no required reference profile in the database, the user can request the missing profile from **RIFTEK** (free service).

30.2.8. Measurement scheme

The measurement scheme is meant as a sequence of making measurements/processing of wheels in the rolling stock with specified parameters of each wheelset (wheelset numbers, car numbers, series, etc.). The program automatically offers the operator to perform measurement of the wheel in accordance with selected scheme of wheel processing. The program contains several preset schemes. Besides, the user can form his own measurement scheme.

30.2.8.1. Selection or removal of the measurement scheme

To select the measurement scheme file, press **Scheme**.

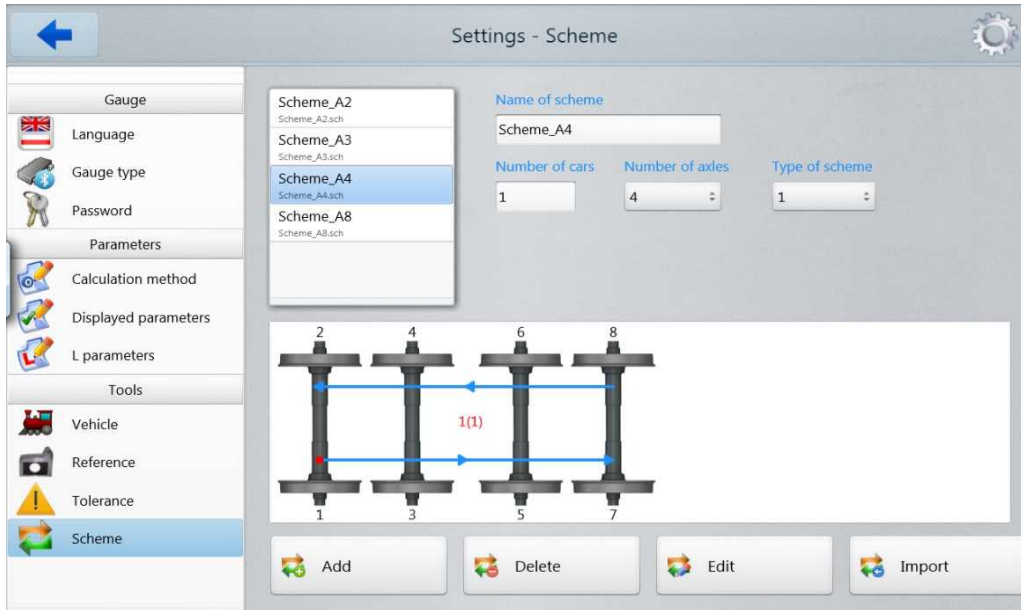

Arrows in the figure show the direction of processing of wheelsets as well as the names assigned to wheels.

To delete the scheme file, activate the line and press **Delete**. If you delete the current scheme, the error message will appear.

To add the scheme file, press **Import** and select the *.sch file.

30.2.8.2. Formation of a new measurement scheme

To form a new measurement scheme, press **Add**. The following window will appear:

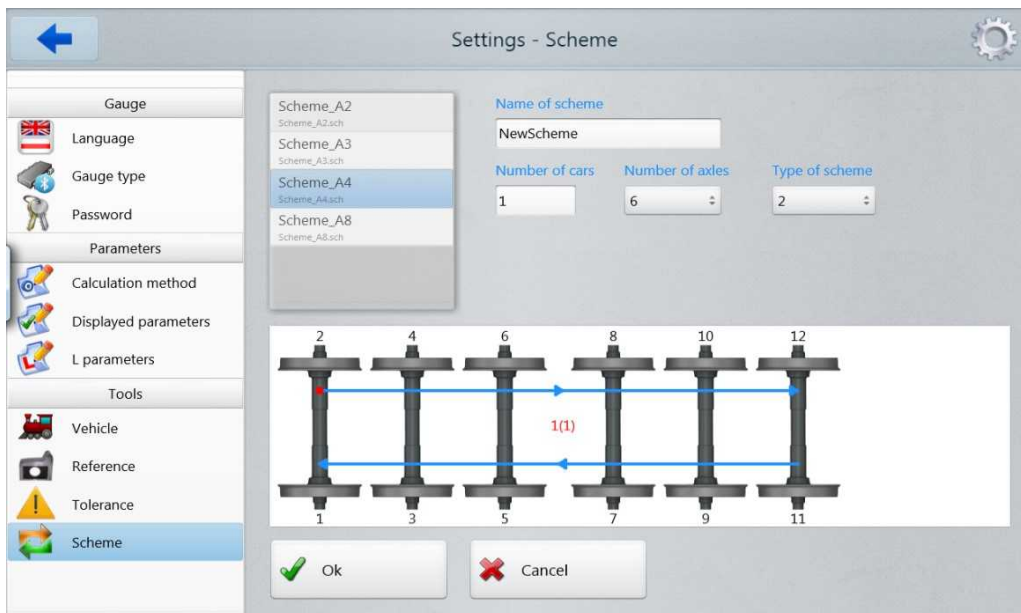

Next:

- Enter the scheme name.
- Select the number of cars.
- Select the number of axes.

- Select the wheel processing scheme out of the options suggested.
- Press **Ok**.

This method of the measurement scheme formation allows to create only simple schemes without specifying the wheelset numbers, car numbers, series, etc.

30.2.9. Tolerances

The program automatically controls measured geometric parameters for going out beyond the tolerances set. It is possible for the user to create groups of tolerances. Control of parameters will be performed for a selected group.

To select a current group of tolerances, press **Tolerance**. The table will show tolerances only for the selected geometric parameters of the wheel.

A red color indicates the maximum/minimum critical values of parameters. An orange color indicates the maximum/minimum values, which are close to critical values.

139

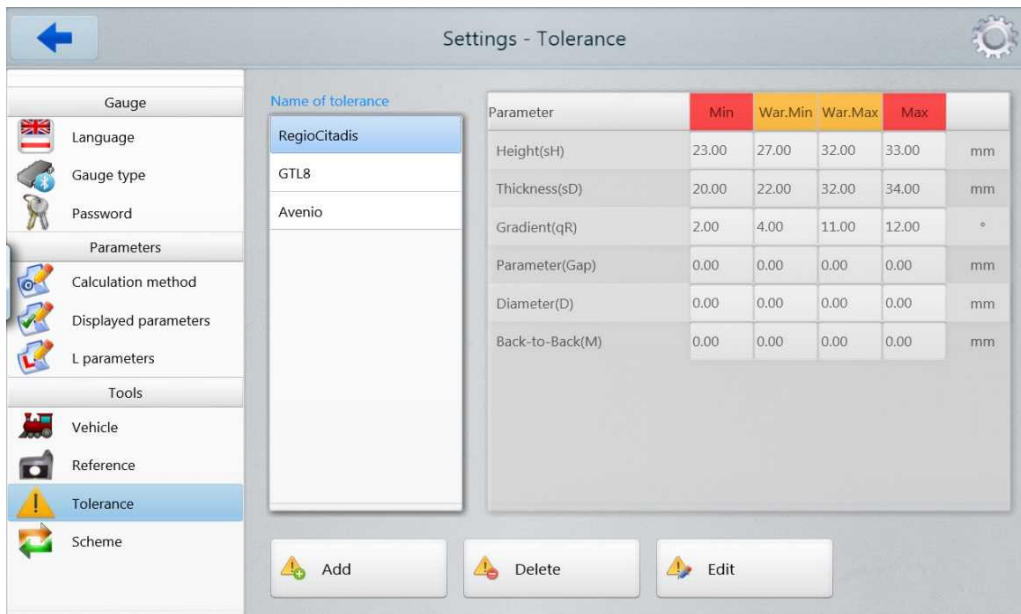

To delete the tolerance, activate the line and press **Delete**.

To edit the tolerance, activate the line and press **Edit**.

To add a new tolerance, activate the line and press **Add**. On the screen:

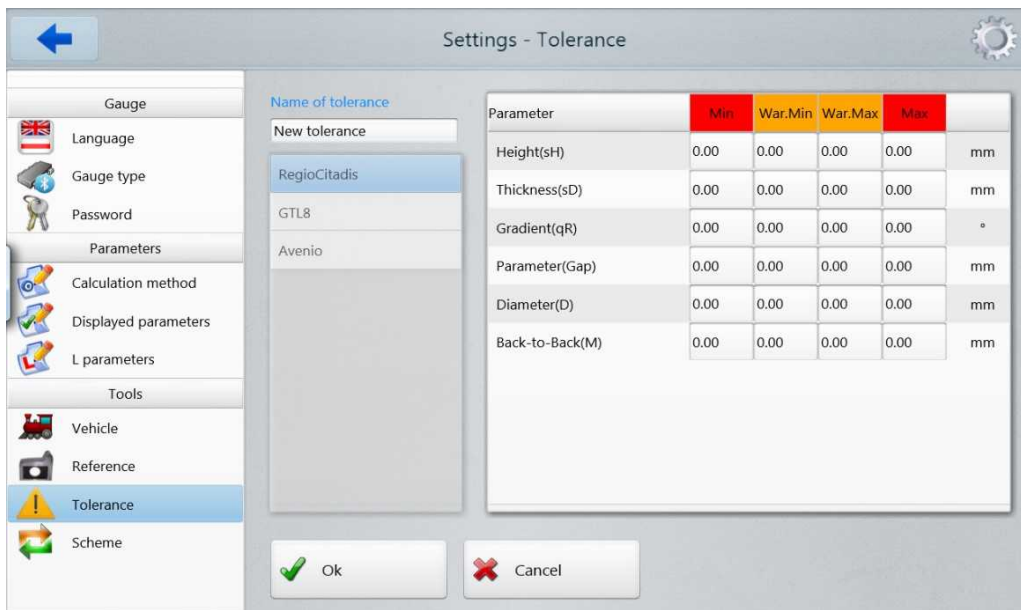

Enter the tolerance name into the **Name of tolerance** field and the values into the **Min/War.Min/War.Max/Max** fields. To save the changes, press **Save**.

30.2.10. Vehicles

To view a list of rolling stocks, press **Vehicle**. The listed rolling stocks can be selected for measurement.

Parameters of the rolling stocks:

Vehicle name	Name of the rolling stock
Vehicle Id	Identification number of the rolling stock
Vehicle description	Description of the rolling stock
Schedule	Schedule for the rolling stock
Send to AURA	Select "Yes" if you want to send data to the AURA database, or select "No" if you don't
Scheme	Measurement scheme name
# axles	Number of axles
# wheels	Number of wheels
Reference	Reference name from a list of references (Reference tab)
Tolerance	Tolerance name from a list of tolerances (Tolerance tab)

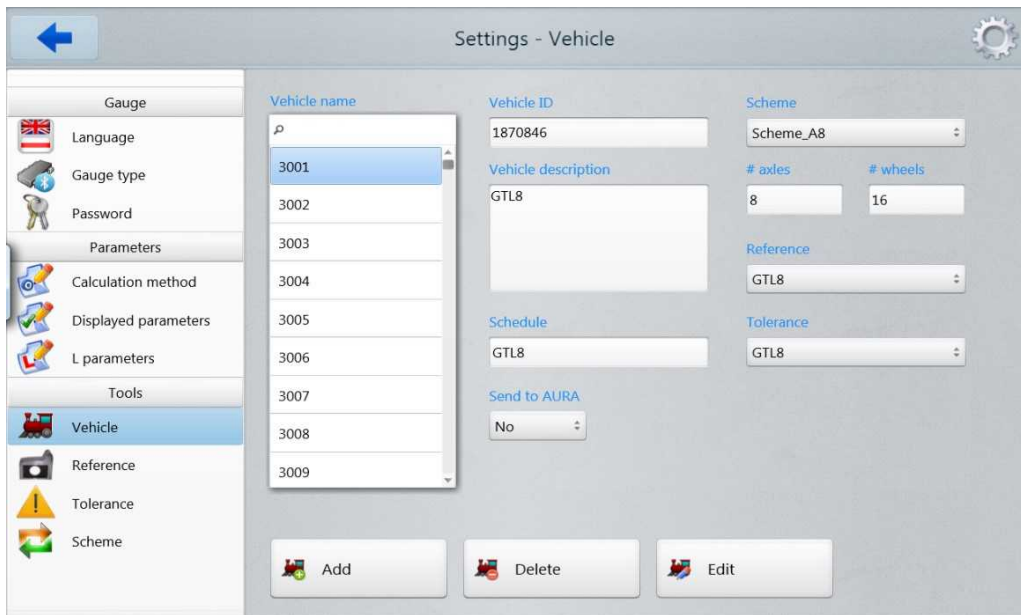

To delete the rolling stock, activate the line and press **Delete**.

To edit the rolling stock, activate the line and press **Edit**.

To add a new rolling stock, activate the line and press **Add**.

30.3. Measurements

There are three types of measurements:

1. Single Measurement – measurement without specifying the rolling stock type, measurement scheme, tolerances. Measurement results can be saved to the WMC format.
2. Simple Measurement – measurement of the selected rolling stock with specifying the scheme and tolerances. Measurement results are saved to the WMC format.
3. Automated Measurement – measurement of the selected rolling stock with specifying the scheme and tolerances. Measurement results are transferred to the AURA database.

30.3.1. Single measurement

To enter the mode, press the **Single Measurement** button.

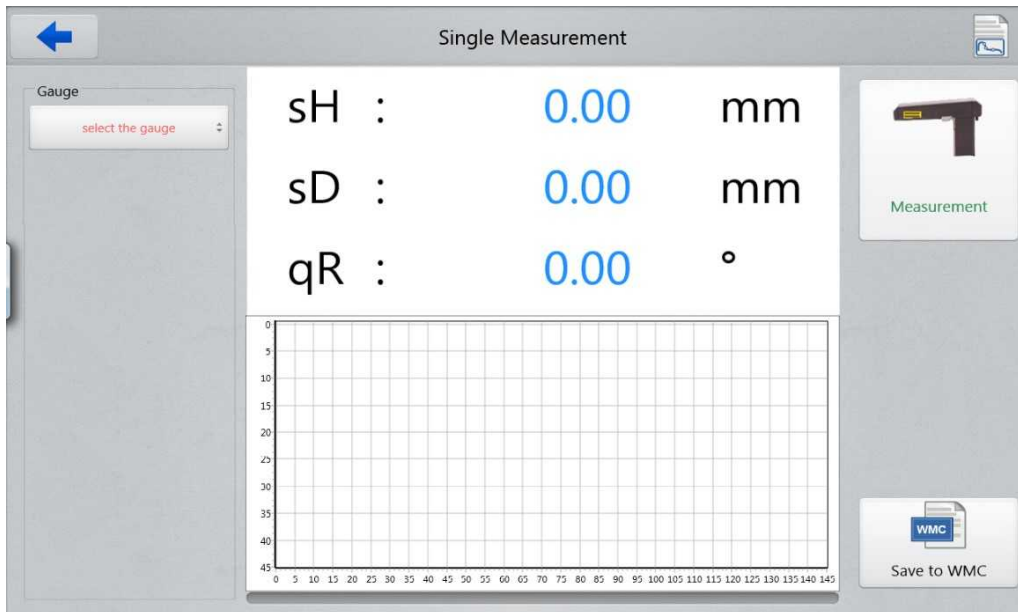

First, you need to establish the Bluetooth connection to the gauge: IKP, IDK or IMR.

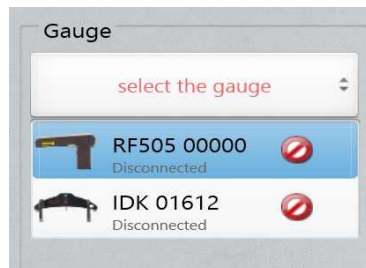

The list contains devices selected in settings (see Par. [30.2.2.](#) "Gauge type selection"). After selecting, press the **Connect** button.

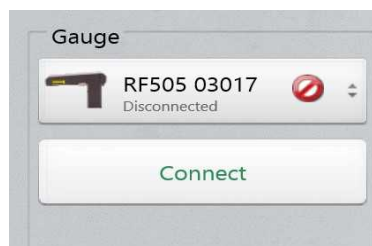

The **Measurement** button and the charging indicators will be active.

- Press the **Measurement** button.
- After pressing the **Measurement** button, the laser module starts scanning of the wheel surface. During the scanning process (1-2 seconds), a red LED is lit.
- When the scanning process is complete, the program displays the measurement results.

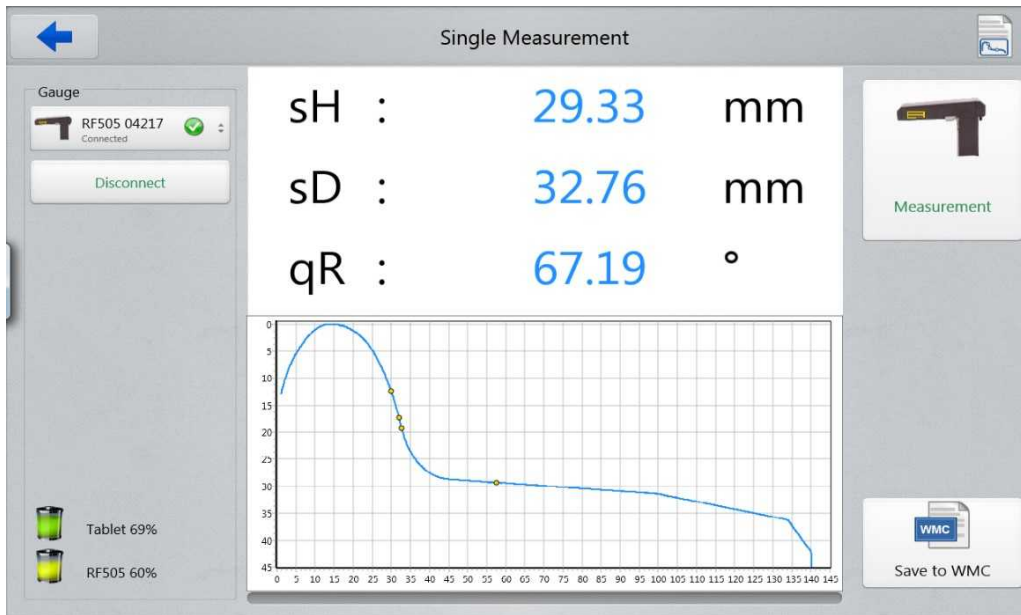

Measurement results and profile coordinates can be saved to the file of the WMC format. The files are saved to the following directory:
C:\Riftek,LLC\Ikp5_Tablet\Measurements\Losse metingen

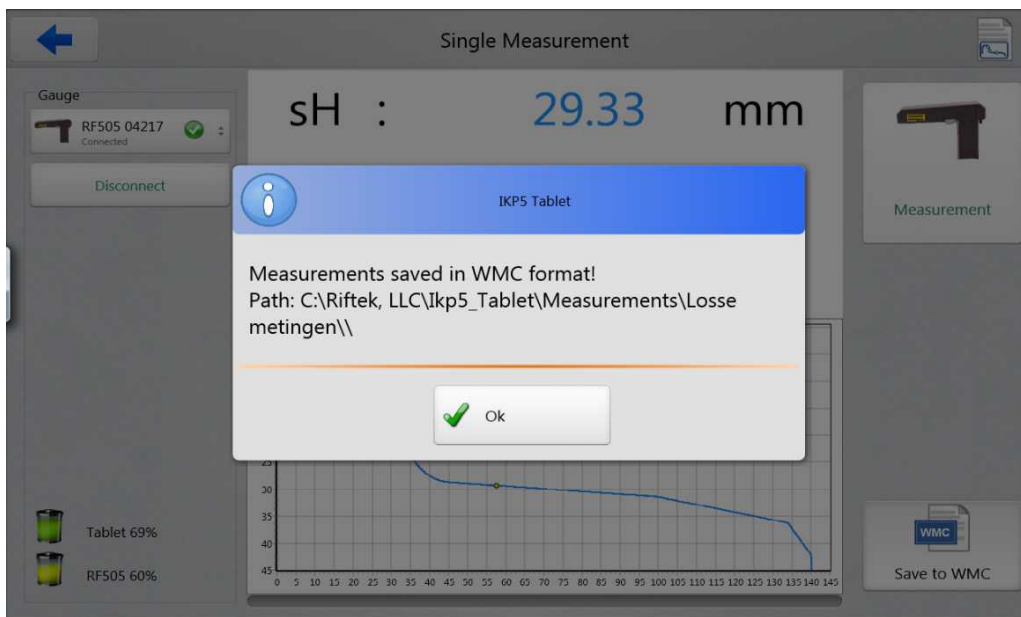

The IDK is designed to measure the wheel diameter. The IMR is designed to measure the back-to-back distance. In order to change the gauge type, press the **Disconnect** button, select the gauge you need, and press **Connect**. The measurement procedure is similar to IKP.

30.3.2. Simple measurement

To enter the mode, press the **Simple Measurement** button. This mode allows to perform measurements in accordance with the rolling stock parameters (scheme, tolerances, reference).

First, you need to select the rolling stock in the **Select Vehicle** window. The list contains only those rolling stocks, the measurement results of which will not be sent to the AURA database (the **Send to AURA** column is empty).

143

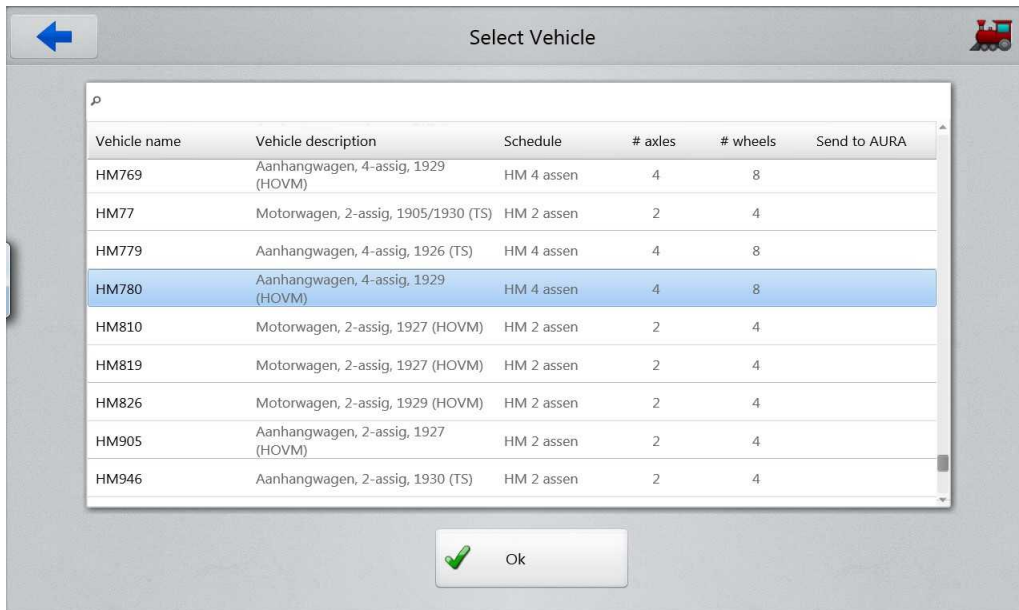

Select the rolling stock (or specify its name in the search line) and press **OK**. The program will show the measurement scheme and parameters for the selected rolling stock.

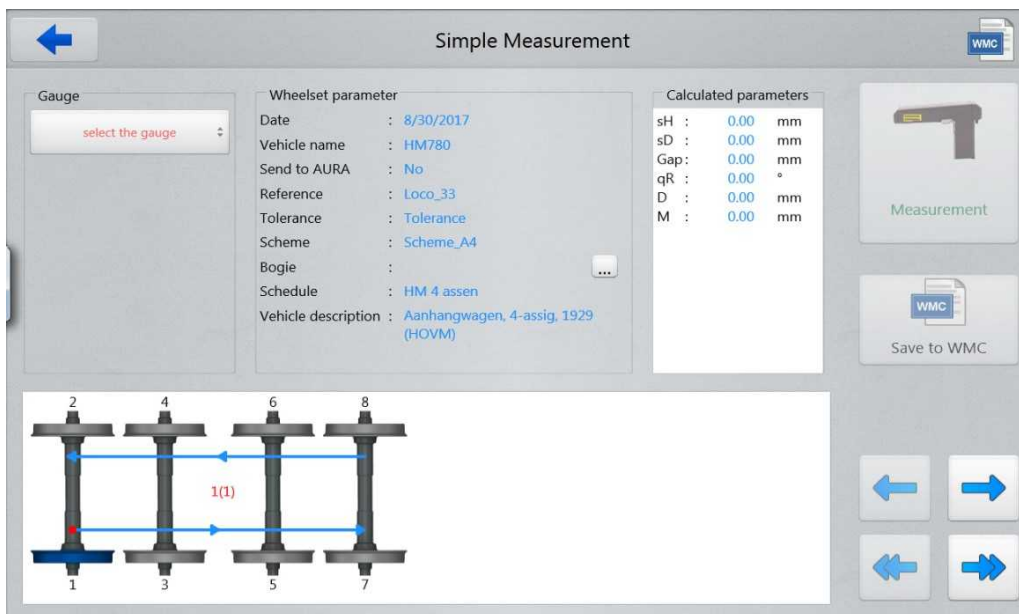





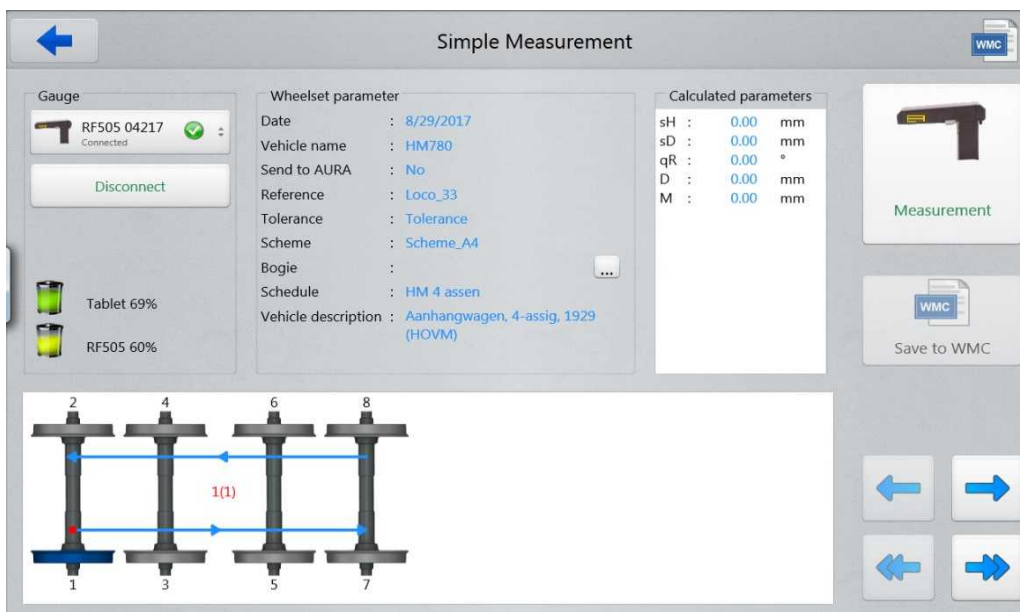



Next, select and connect the gauge: IKP, IDK or IMR. The connection procedure is described in the previous paragraph.

When the connection is established, the **Measurement** button will be active and you can start measurements.



Designations and buttons:

	an ordinal number of the car to be measured (number of cars in the rolling stock)
	pass to the previous/next wheel
	pass to the previous/next car
	a measured wheel
	a wheel to be measured the next time
	a non-measured wheel
	parameters of the measured wheel are beyond the tolerances
	parameters of the measured wheel are close to the tolerances
	measurement

30.3.2.1. Measurement

- Press the **Measurement** button in order to measure the wheel offered by the program (highlighted in green). The laser module will scan the wheel surface.
- Upon completion of the scanning process, the program will show the values of selected geometrical parameters.

145

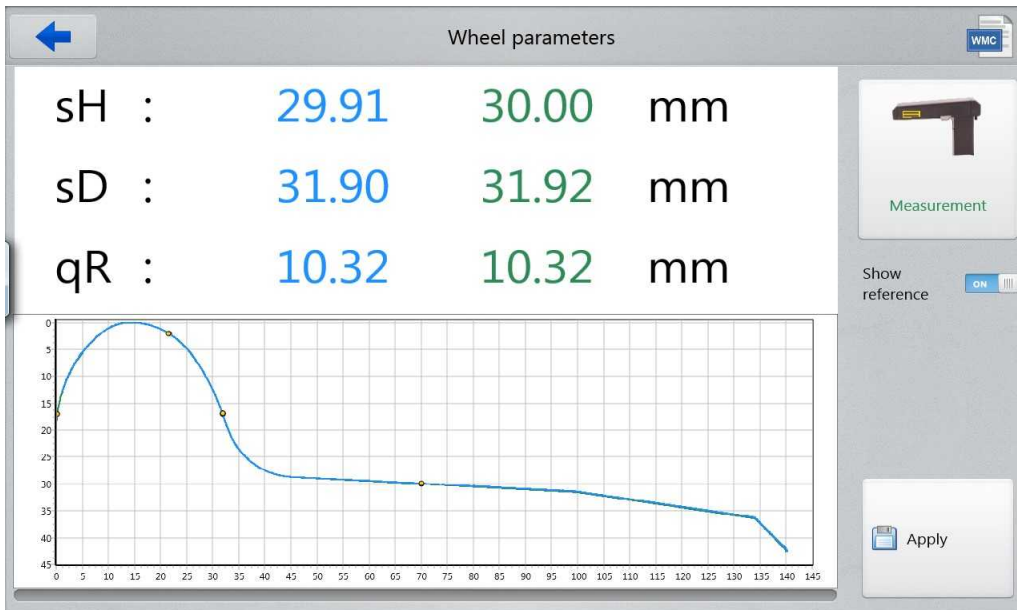

When the value is beyond the tolerances, it will be highlighted in red:

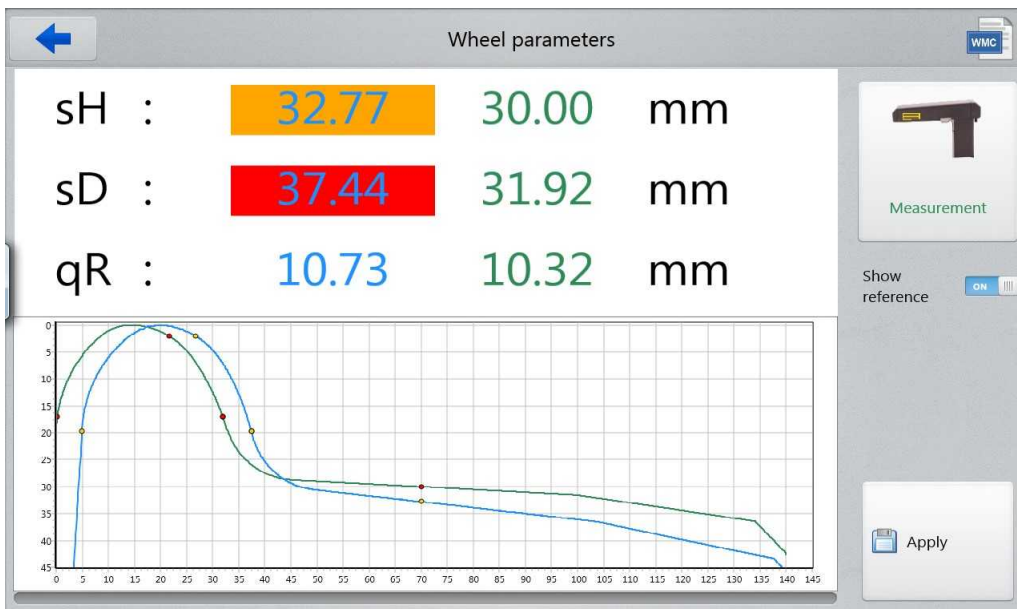

The program allows to display only parameters of the measured profile. To hide the reference values, you need to disable the **Show Reference** option (select "Off").

- To repeat the measurement, press the **Measurement** button.
- When a satisfactory result is obtained, press the **Save** button to save it.
- The program will offer to pass to the measurement of the next wheel in accordance with the selected scheme of measurement.

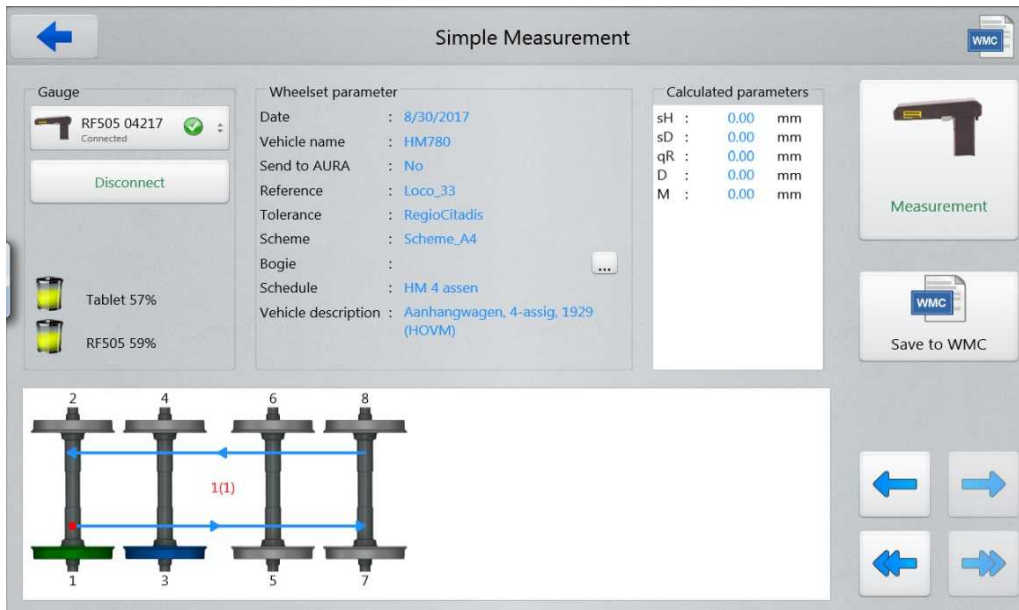

- To view the results of previous measurements, you can use the arrows. If you select the measured wheel, the program will display the saved wheel parameters.

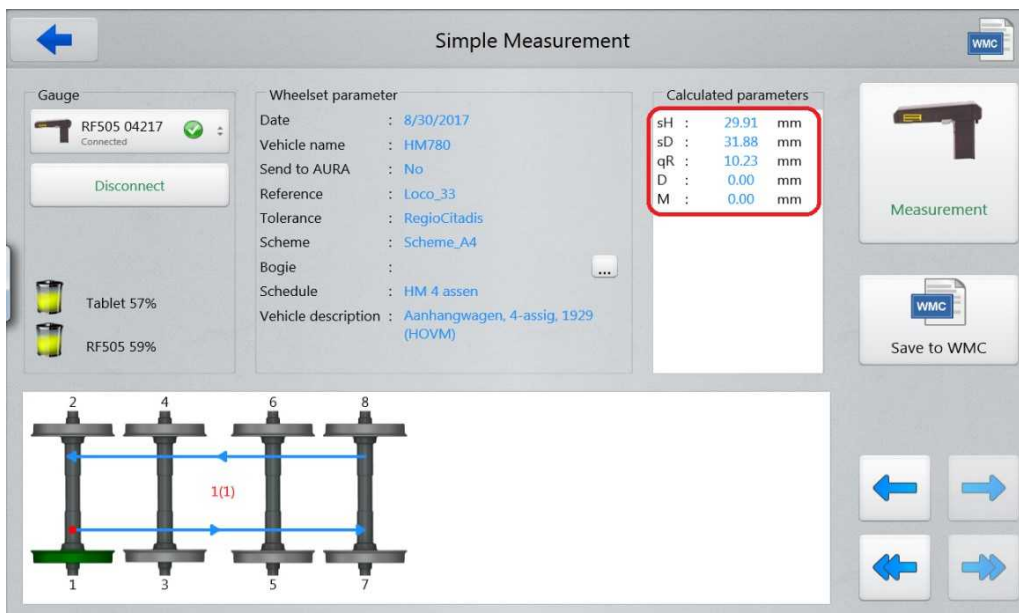

- When you measure the wheel that was already measured, the program prompts you to replace the existing values with the new ones.

The measurement results can be saved in the WMC format. Each measurement is saved in a separate file. The path:

C:\Riftek LLC\lcp5_Tablet\Measurements\WMC\HM780_20170830

Where **HM780_20170830** is the directory name, **HM780** is the rolling stock name, **20170830** is the date of measurement (yyyymmdd).

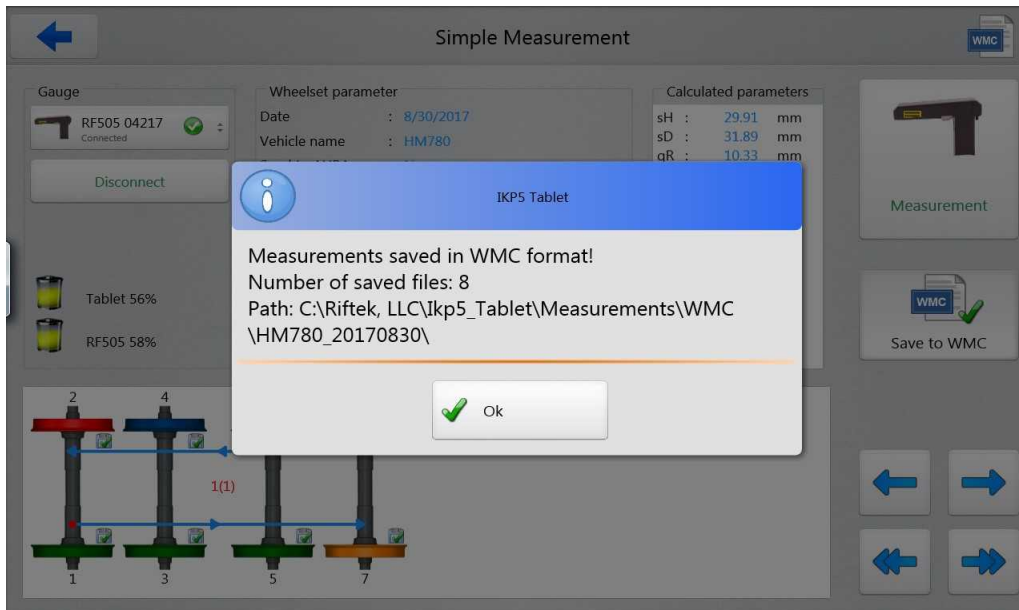

30.3.2.2. Measuring by IDK, IMR

To measure the wheel diameter and back-to-back distance, disconnect from IKP by pressing the **Disconnect** button, and select the gauge you need: IDK (to measure the wheel diameter), or IMR (to measure the back-to-back distance).

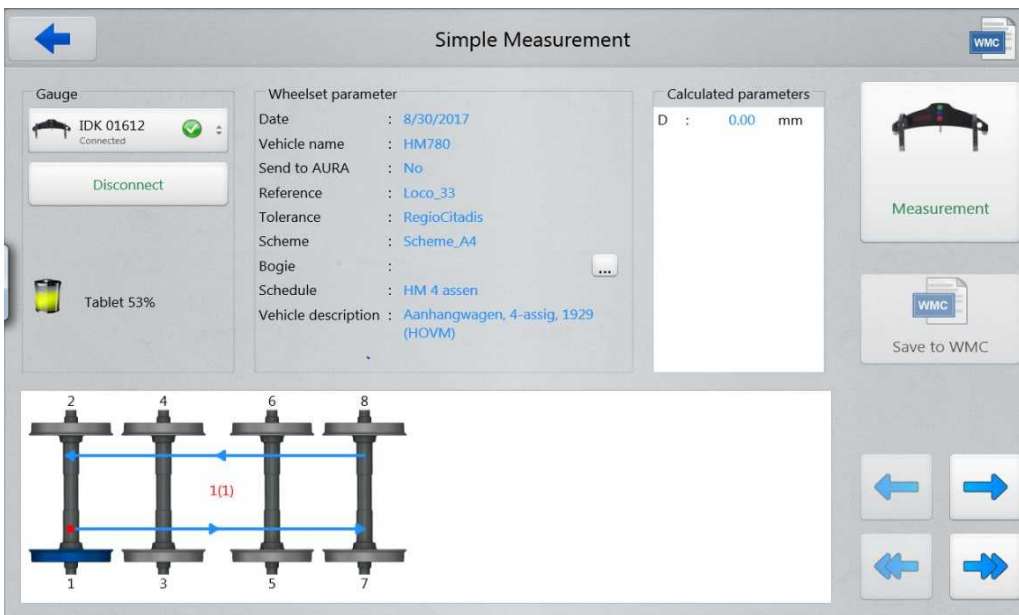

The measurement process is similar to IKP.

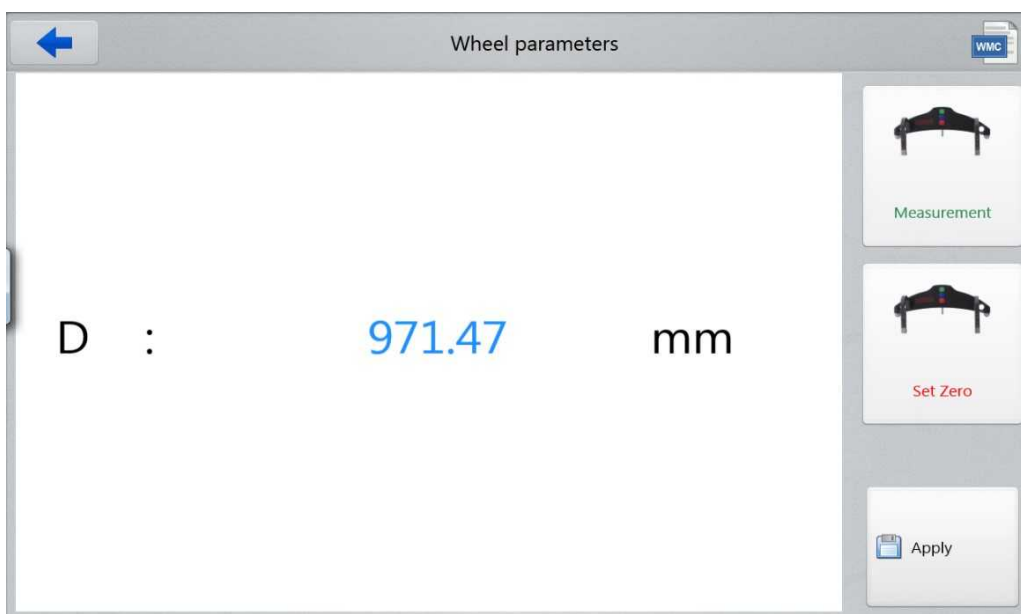

The measurement results can be saved in the WMC format. Each measurement is saved in a separate file.

30.3.3. Automated measurement

The **Automated Measurement** mode as well as the **Simple Measurement** mode allows to perform measurements in accordance with the rolling stock parameters (scheme, tolerances, reference).

The only difference is that the list contains only those rolling stocks, the measurement results of which will be imported to the AURA database (the **Send to AURA** column is ticked).

 **Attention!** The Internet connection is required in order to connect to the AURA database and to transmit data.

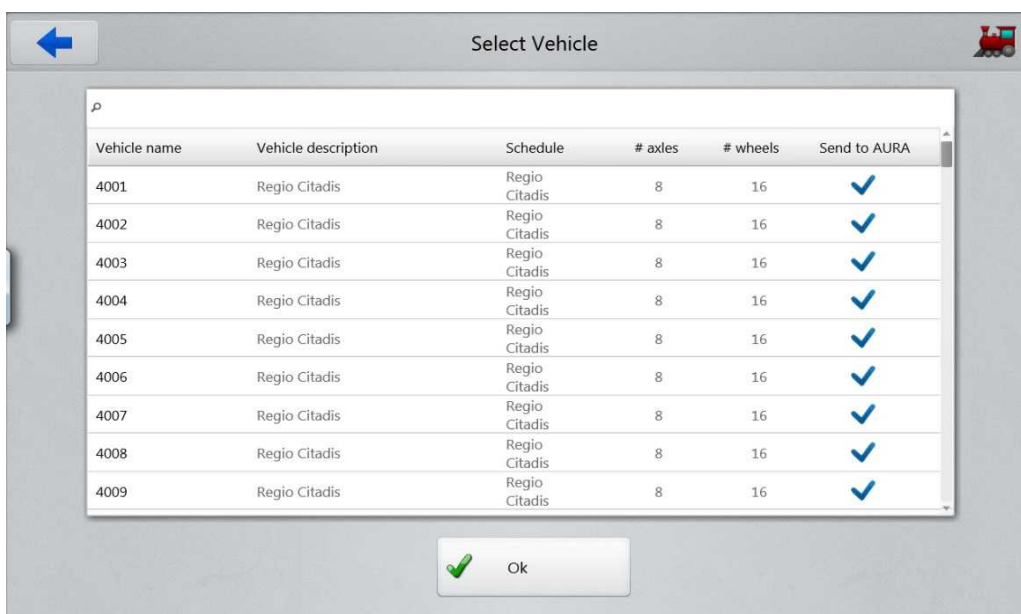

The measurement procedure has one difference from the **Simple Measurement** mode. In order to import data to the AURA database, it is necessary to measure all cars of the selected rolling stock according to the measurement scheme. Only in this case the **Send to AURA** button will be active.

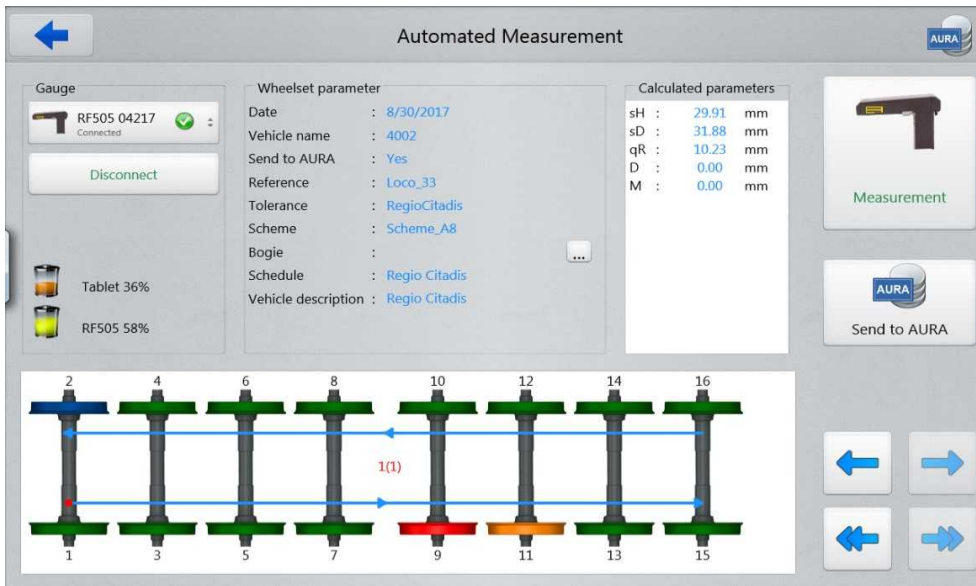

After pressing the **Send to AURA** button, the data transmission window appears. In case of successful identification in the AURA system, the data transmission starts.

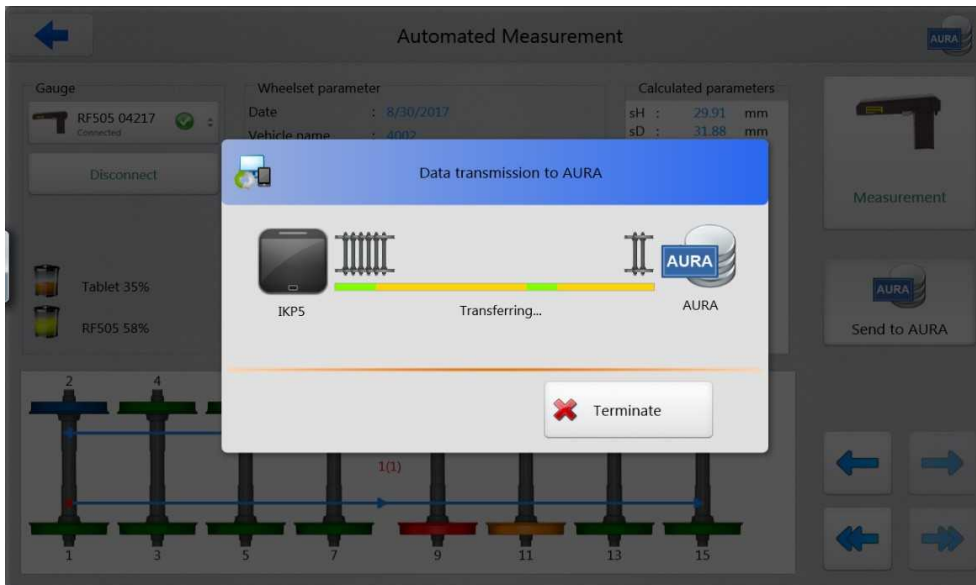

When the data is successfully transferred, the following message appears:

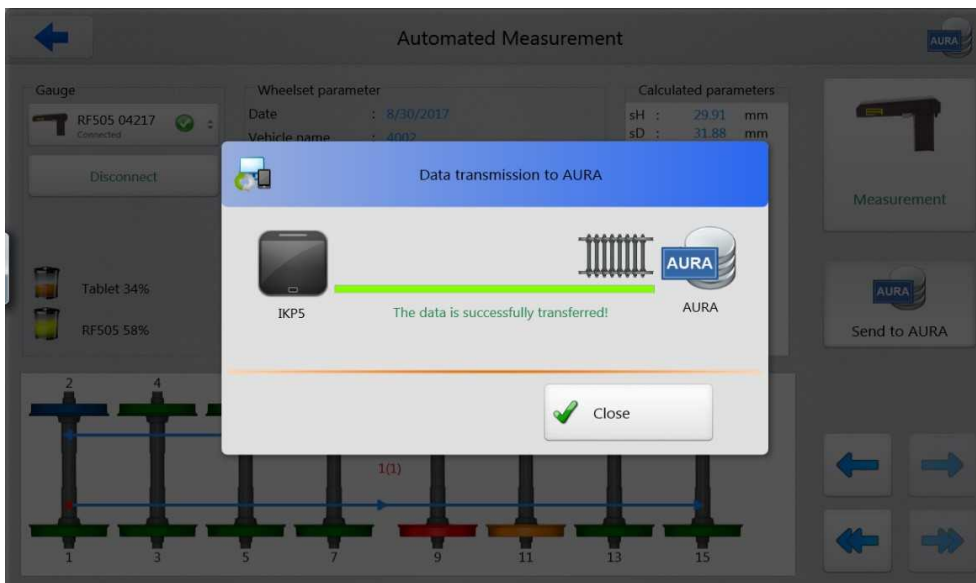

If any error occurs while connecting to the AURA system (for example, if there is no Internet connection), the error message appears.

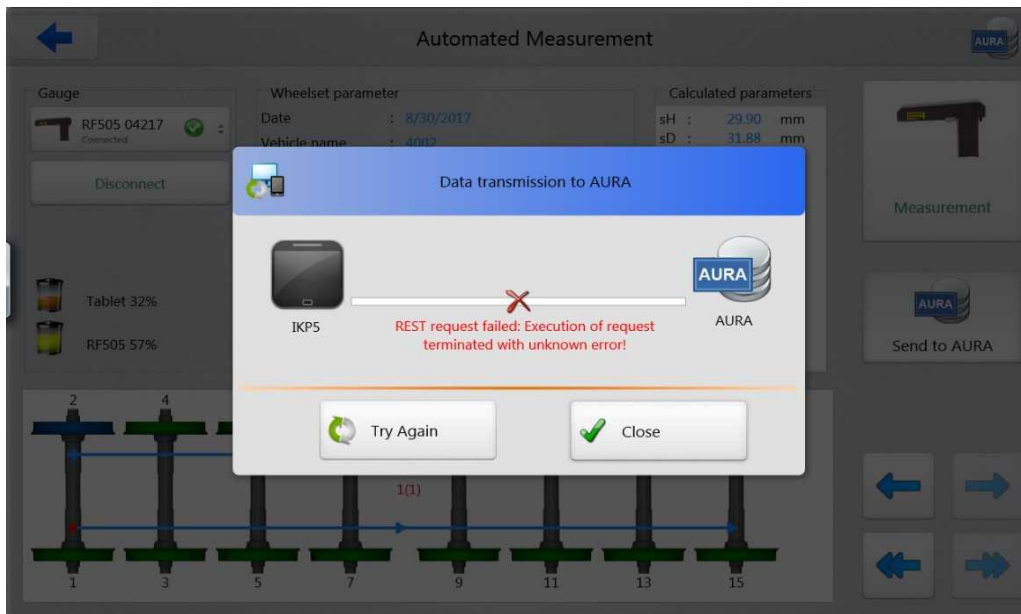

In this case, you need to check the Internet connection and try to transmit data again by pressing the **Try Again** button.

To avoid the data loss, all measurement results are also copied to the directory:

C:\Riftek LLC\Ikp5_Tablet\Measurements\ AURA\4002_20170830

Where **4002_20170830** is the directory name, **4002** is the rolling stock name, **20170830** is the date of measurement (yyyymmdd).

31. Warranty policy

Warranty assurance for the Laser Profilometer – 24 months from the date of putting in operation; warranty shelf-life – 12 months.

32. List of changes

Date	Revision	Description
17.05.2017	1.0.0	Starting document.
10.11.2017	1.1.0	Added Annex 4 "Software application for working with the A.U.R.A. Wheel system".
14.01.2024	2.0.0	Describes how to work with an Android device. The laser module options have been clarified. Hollow measurement principle clarified.

33. Distributors

AUSTRALIA

**Applied Measurement
Australia Pty Ltd**
RAILWAY INSTRUMENTS ONLY
Thornton Plaza, Unit 5,
27 Thornton Crescent, Mitcham
VIC 3132, Australia
Tel: +61 39874 5777
Fax: +61 39874 5888
sales@appliedmeasurement.com.au
www.appliedmeasurement.com.au

BELGIUM

**Althen Sensors & Controls
BV**
Verrijn Stuartlaan 40, 2288 EL,
Rijswijk, Leidschendam
The Netherlands
Tel: +31 0 70 392 4421
Tel: +31 0 61 396 7830
Tel: +31 0 64 323 8393
sales@althen.nl
info@althen.nl
www.althensensors.com

BOSNIA AND HERZEGOVINA

ASCO RAIL sp. z o.o.
**EXCLUSIVE REPRESENTATIVE
FOR RAILWAY EQUIPMENT**
ul. Wielowiejska 53, 44-120
Pyskowice, Poland
Tel: +48 32 230 45 70
Fax: + 48 32 233 21 34
biuro@ascorail.pl
export@ascorail.pl
www.ascorail.pl

BRAZIL**CAPI Controle e Automação Ltda**

Rua Itororó, 121, CEP 13466-240
Americana-SP, Brazil
Tel: +55 19 36047068
Fax: +55 19 34681791
capi@capicontrol.com.br
www.capicontrol.com.br

BULGARIA**ASCO RAIL sp. z o.o.
EXCLUSIVE REPRESENTATIVE
FOR RAILWAY EQUIPMENT**

ul. Wielowiejska 53, 44-120
Pyskowice, Poland
Tel: +48 32 230 45 70
Fax: + 48 32 233 21 34
biuro@ascorail.pl
export@ascorail.pl
www.ascorail.pl

CHILE**MOL INGENIERIA LTDA
EXCLUSIVE REPRESENTATIVE
FOR RAILWAY EQUIPMENT**

República de Honduras 11936
Las Condes, Santiago de Chile
Tel: +56 9 59200362
hconcha@molingenieria.com
www.molingenieria.com

CHILE**Verne SpA**

Apoquindo 2818, oficina 31
Las Condes, Santiago, Chile
Tel: +56 2 228858633
info@verne.cl
jsaavedra@verne.cl
www.verne.cl

CHINA**Beijing Haiwei Lutong
Technology Co., Ltd**

Yard 1, Tianjing Street, Fangshan
District, Beijing, China
Tel: +86 10 8366 1866
Fax: +86 10 8366 1866
info@haiwlt.com
www.haiwlt.com

CHINA**Chongqing Wolf Industrial
Technology Co., Ltd**

Room 2307 / 2308, Light of City
international business building,
No. 19 Jiangnan Avenue, Nan'an
District, Chongqing, China
Tel: 023 62832618
Fax: 023 62832113
info@wolf-hk.com
www.wolf-hk.com

CHINA**Beijing Gemston Mechanical
& Electrical Equipment Co.,
Ltd**

RAILWAY INSTRUMENTS ONLY
Room 613, Anfu Mansion, Fengtai
District, Beijing, China
Tel: +86 10 6765 0516
Fax: +86 10 6765 6966
Mobile: +86 137 1755 1423
dh0526@163.com
www.baoft.cn

CHINA**Xi'an Win-Success
Automation Technology
Co.,Ltd**

Room 3-1-1039, Iduhui Building,
No.11 Tangyan South Road
High-Tech Zone, Xi'an
Shaanxi PRC, China
Tel: +86 29 81106280
Fax: +86 29 81106285
Mob: +86 133 19271405
info@maxsensor.com
www.maxsensor.com

CHINA**Micron-Metrology co., Ltd**

No.2, Kecheng Rd., Industrial Park
District, Suzhou,
Jiangsu Province., China
Tel: 0512 65589760
Mob: +86 189 1806 9807
sales@micron-metrology.cn
www.micron-metrology.cn

CHINA**Zhenshangyou Technologies
Co., Ltd**

Rm 2205-2210, Zhongyou Hotel
1110 Nanshan Road, Nanshan
District 518054 Shenzhen, China
Tel: +86 755-26528100/8011/8012
Fax: +86 755-26528210/26435640
info@51sensors.com
www.51sensors.com

CROATIA**ASCO RAIL sp. z o.o.
EXCLUSIVE REPRESENTATIVE
FOR RAILWAY EQUIPMENT**

ul. Wielowiejska 53, 44-120
Pyskowice, Poland
Tel: +48 32 230 45 70
Fax: + 48 32 233 21 34
biuro@ascorail.pl
export@ascorail.pl
www.ascorail.pl

CZECH REPUBLIC**ASCO RAIL sp. z o.o.
EXCLUSIVE REPRESENTATIVE
FOR RAILWAY EQUIPMENT**

ul. Wielowiejska 53, 44-120
Pyskowice, Poland
Tel: +48 32 230 45 70
Fax: + 48 32 233 21 34
biuro@ascorail.pl
export@ascorail.pl
www.ascorail.pl

DENMARK**BLConsult**

Ryssbält 294
95 291 Kalix, Sweden
Tel: +46 70 663 19 25
info@blconsult.se
www.blconsult.se

ESTONIA**FoodLab OÜ**

Haabersti linnaosa, Astangu tn 52
13519 Eesti, Tallinn, Estonia
Tel: +372 56 363110
foodlab.ee@gmail.com

FINLAND**Kvalitest Industrial AB**

**EXCEPT FOR RAILWAY
INSTRUMENTS**
Ekbacksvägen 28,
16869 Bromma, Sweden
Tel: +46 0 76 525 5000
sales@kvalitest.com
www.kvalitest.com
www.kvalitest.se

FINLAND**TERÄSPYÖRÄ-STEELWHEEL
OY****RAILWAY INSTRUMENTS ONLY**

Juvan teollisuuskatu 28
FI-02920 ESPOO, Finland
Tel: +358 400 422 900
Fax: +358 9 2511 5510
steelwheel@steelwheel.fi
www.teraspyora.fi

GERMANY**Finger GmbH & Co. KG
OPTICAL MICROMETERS ONLY**

Sapelloh 172, 31606
Warmen, Germany
Tel: +49 5767 96020
Fax: +49 5767 93004
finger@finger-kg.de
www.finger-kg.de

INDIA**Influx Big Data Solutions Pvt
Ltd**

No:2, Krishvi, Ground Floor,
Old Airport Road, Domlur,
Bangalore - 560071, India
Tel: +91 73 37748490
Tel: +91 94 48492380
milan@influxtechnology.com
support_india@influxtechnology.com
www.influxtechnology.com

ISRAEL**Nisso Dekalo Import
Export LTD**

1 David Hamelech Street
Herzlia 46661 Israel
Tel: +972 99577888
Fax: +972 99568860
nissodekaloltd@outlook.com
www.fly-supply.net
www.aircraft-partsupply.com

LATVIA**FoodLab OÜ**

Haabersti linnaosa, Astangu tn 52
13519 Eesti, Tallinn, Estonia
Tel: +372 56363110
foodlab.ee@gmail.com

FRANCE**BLET Measurement Group
S.A.S.**

1 avenue du Président Georges
Pompidou, 92500 Rueil
Malmaison, France
Tel: + 33 0 1 80 88 57 85
Fax: +33 0 1 80 88 57 93
technique@blet-mesure.fr
www.blet-mesure.fr

GERMANY**ALTHEN GmbH Meß- und
Sensortechnik**

Dieselstrasse 2, 65779
Kelkheim, Germany
Tel: +49 0 6195 7 00 60
info@althen.de
www.althensensors.com/de/

INDIA**Paragon Instrumentation
Engineers Pvt. Ltd.****RAILWAY INSTRUMENTS ONLY**

200, Station Road,
Roorkee, 247 667, India
Tel: +91 1332 272394
tanuj@paragoninstruments.com
www.paragoninstruments.com

ITALY**FAE s.r.l.**

Via Tertulliano, 41
20137 Milano, Italy
Tel: +39 02 55187133
Fax: +39 02 55187399
fae@fae.it
www.fae.it

LUXEMBOURG**Althen Sensors & Controls
BV**

Verrijn Stuartlaan 40, 2288 EL,
Rijswijk, Leidschendam
The Netherlands
Tel: +31 0 70 392 4421
Tel: +31 0 61 396 7830
Tel: +31 0 64 323 8393
sales@althen.nl
info@althen.nl
www.althensensors.com

GERMANY**Disynet GmbH**

Breyeller Str. 2, 41379
Brueggen, Germany
Tel: +49 2157 8799 0
Fax: +49 2157 8799 22
disynet@sensoren.de
www.sensoren.de

HUNGARY**ASCO RAIL sp. z o.o.
EXCLUSIVE REPRESENTATIVE
FOR RAILWAY EQUIPMENT**

ul. Wielowiejska 53, 44-120
Pyskowice, Poland
Tel: +48 32 230 45 70
Fax: + 48 32 233 21 34
biuro@ascorail.pl
export@ascorail.pl
www.ascorail.pl

INDONESIA**PT. DHAYA BASWARA
SANIYASA**

Botanic Junction Blok H-9 NO. 7
Mega Kebon Jeruk, Joglo
Jakarta, 11640, Indonesia
Tel: +62 21 2932 5859
management@ptdbs.co.id

JAPAN**Tokyo Instruments, Inc.**

6-18-14 Nishikasai, Edogawa-ku,
Tokyo, 134-0088 Japan
Tel: +81 3 3686 4711
Fax: +81 3 3686 0831
f_kuribayashi@tokyoinst.co.jp
www.tokyoinst.co.jp

MALAYSIA**OptoCom InstruVentures**

H-49-2, Jalan 5, Cosmoplex
Industrial Park, Bandar Baru
Salak Tinggi, Sepang, Malaysia
Tel: 603 8706 6806
Fax: 603 8706 6809
optocom@tm.net.my
www.optocom.com.my

MONTENEGRO

ASCO RAIL sp. z o.o.
**EXCLUSIVE REPRESENTATIVE
FOR RAILWAY EQUIPMENT**
ul. Wielowiejska 53, 44-120
Pyskowice, Poland
Tel: +48 32 230 45 70
Fax: + 48 32 233 21 34
biuro@ascorail.pl
export@ascorail.pl
www.ascorail.pl

NETHERLANDS

**Althen Sensors & Controls
BV**
Verrijn Stuartlaan 40, 2288 EL,
Rijswijk, Leidschendam
The Netherlands
Tel: +31 0 70 392 4421
Tel: +31 0 61 396 7830
Tel: +31 0 64 323 8393
sales@althen.nl
info@althen.nl
www.althensensors.com

NORWAY

BLConsult
Ryssbält 294,
95 291 Kalix, Sweden
Tel: +46 70 663 19 25
info@blconsult.se
www.blconsult.se

153**NORWAY**

Salitec AS
PB 468, N-1327
Lysaker, Norway
Tel: +47 23 891015
Fax: +47 92101005
mail@salitec.no
www.salitec.no

PERU

Verne Perú S.A.C.
Las Codornices 104,
Surquillo, Lima, Peru
Tel/fax: +51 992436734
info@verne.cl
www.verne.cl

POLAND

ASCO RAIL sp. z o.o.
**EXCLUSIVE REPRESENTATIVE
FOR RAILWAY EQUIPMENT**
ul. Wielowiejska 53, 44-120
Pyskowice, Poland
Tel: +48 32 230 45 70
Fax: + 48 32 233 21 34
biuro@ascorail.pl
export@ascorail.pl
www.ascorail.pl

POLAND

RIFTEK EUROPE sp. z o.o.
ul. Domaniewska 17/19, 02-672
Warsaw, Poland
info@riftek.com
www.riftek.com

PORTUGAL

**Campal Inovacoes
Ferroviarias Lda.**
Lagoas Park, Edificio 7, 1° Piso
Sul, 2740-244 Porto Salvo, Oeiras,
Portugal
Tel: +351 21 584 4348
campal@campal.pt
www.campal.pt

SERBIA

ASCO RAIL sp. z o.o.
**EXCLUSIVE REPRESENTATIVE
FOR RAILWAY EQUIPMENT**
ul. Wielowiejska 53, 44-120
Pyskowice, Poland
Tel: +48 32 230 45 70
Fax: + 48 32 233 21 34
biuro@ascorail.pl
export@ascorail.pl
www.ascorail.pl

SLOVAKIA

ASCO RAIL sp. z o.o.
**EXCLUSIVE REPRESENTATIVE
FOR RAILWAY EQUIPMENT**
ul. Wielowiejska 53, 44-120
Pyskowice, Poland
Tel: +48 32 230 45 70
Fax: + 48 32 233 21 34
biuro@ascorail.pl
export@ascorail.pl
www.ascorail.pl

SLOVENIA

ASCO RAIL sp. z o.o.
**EXCLUSIVE REPRESENTATIVE
FOR RAILWAY EQUIPMENT**
ul. Wielowiejska 53, 44-120
Pyskowice, Poland
Tel: +48 32 230 45 70
Fax: + 48 32 233 21 34
biuro@ascorail.pl
export@ascorail.pl
www.ascorail.pl

SOUTH KOREA

BS Holdings
B-201, Wonpogongwon 1ro,
59 Danwon-gu, Ansan-si,
Gyeonggi-do 15455, Republic of
Korea
Tel: +82 31 411 5011
Fax: +82 31 411 5015
bsh5011@hanmail.net
www.lasersolution.co.kr

SOUTH KOREA

PROSEN. CO., LTD
M-1001, Songdo techno park IT
center, 32, Songdogwahak-ro,
Yeonsu-gu, Incheon, 21984,
Republic of Korea
Tel: +82 32 811 3457
Fax: +82 32 232 7458
trade@prosen.co.kr
www.prosen.co.kr

SPAIN

IBERFLUID Instruments S.A.
C/ Botanica, 122, 08908
L'Hospitalet de Llobregat
Barcelona
Tel: +34 93 447 10 65
Fax: +34 93 334 05 24
myct@iberfluid.com
www.iberfluid.com

SWEDEN

BLConsult
Ryssbält 294,
95 291 Kalix, Sweden
Tel: +46 70 663 19 25
info@blconsult.se
www.blconsult.se

SWEDEN**Kvalitest Industrial AB**
EXCEPT FOR RAILWAY
INSTRUMENTS

Ekbacksvägen 28,
16869 Bromma, Sweden
Tel: +46 0 76 525 5000
sales@kvalitest.com
www.kvalitest.com
www.kvalitest.se

SWITZERLAND**ID&T GmbH**

Gewerbstrasse 12/a
8132 Egg (Zurich), Switzerland
Tel: + 41 44 994 92 32
Fax: + 41 44 994 92 34
info@idtlaser.com
www.idtlaser.com

THAILAND**Advantech Solution Co., Ltd.**

20/170 Motorway Rd.,
Kwang Pravet, Khet Pravet,
Bangkok, Thailand 10250
Tel: +662 1848705
Fax: +662 1848708
sales@advantechsolution.com
www.advantechsolution.com

TURKEY**MAK Elektronik Malzeme**
Analiz ve Kalite Kontrol
Cihazlari Dis Tic. Ltd. Sti.

Cenap Sahabettin Sokak, No:39,
34718 Kosuyolu - Kadikoy /
Istanbul - TURKEY
Tel: +90 216 402 10 34
Fax: +90 216 402 10 35
ulastac@metalografi.net
www.makelektronik.com.tr

TURKEY**TEKMA Mühendislik A.S.**

Cevizli Mh. M. Kemal Cd.,
Hukukçular Towers,
A-Blok, No: 66-A/39
Kartal - Istanbul
Tel: +90 216 970 1318
Tel: +90 850 840 2334
info@tekma.eu
www.tekma.eu

UKRAINE**KODA**

Frunze st. 22, 61002,
Harkov, Ukraine
Tel/Fax: +38 057 714 26 54
mail@koda.com.ua
www.koda.com.ua

**UNITED KINGDOM,
IRELAND****Althen UK**

Northamptonshire
United Kingdom
Tel: +44 0 7823 921427
t.stoyles@althen.co.uk
www.althensensors.com
www.althencontrols.com

USA**Althen Sensors & Controls**

2531 Bradley St., Oceanside, CA,
92056, USA
Tel: 858 633 3572
r.ream@althensensors.com

USA, CANADA, MEXICO**Acuity Products of Schmitt
Industries, Inc.**

2765 NW Nicolai Street
Portland, OR, 97210, USA
Tel: +1 503 227 7908
Fax: +1 503 223 1258
sales@acuitylaser.com
www.acuitylaser.com

USA, CANADA, MEXICO**International Electronic
Machines Corporation**
RAILWAY INSTRUMENTS ONLY

850 River Street, Troy,
New York, USA
Tel: +1 518 268-1636
Fax: +1 518 268-1639
marketing@iem.net
www.iem.net

34. RIFTEK's measurement instruments for railway transport



Railway wheel profile gauge, IKP Series

Laser Profilometer IKP-5 Series is employed for:

- Measuring geometrical parameters of the wheel flange (thickness, slope, height), rim/tire thickness.
- Taking full profile of the wheel rolling surface.
- Maintaining the wear database.
- Tolerance control and sorting when checking, inspecting, repairing and forming railway wheelsets.

Measurements are made directly on the rolling stock without rolling out the wheelset.



Rail profile measurement gauge, PRP Series

The main functions of PRP are as follows:

- Obtaining information on the cross-section profile of the railhead acting face.
- Full profile scanning and analysis of the railhead acting face.
- Visualization of combined graphic images of the actual and new cross-section profiles of the railhead.



Wheel diameter measuring gauge, IDK Series

Electronic gauge is designed to measure the wheel rolling circle diameter of railway, metro and tram wheelsets. Measurements are made directly on the rolling stock without rolling out the wheelset.



Back-to-back distance measuring gauge, IMR Series

Electronic gauge is designed to measure the back-to-back distance of railway, metro and tram wheels in the course of checkup, examination, repair and formation of wheelsets. Measurements are made directly on the rolling stock without rolling out the wheelset.



Back-to-back distance measuring gauge, IMR-L Series

Electronic gauge is designed to measure the back-to-back distance of railway, metro and tram wheels in the course of checkup, examination, repair and formation of wheelsets. Measurements are made directly on the rolling stock without rolling out the wheelset.



Disc brakes profile gauge, IKD Series

Electronic gauge is employed for laser scanning and measurement of disc brakes wear parameters.

The main functions of IKD are as follows:

- Obtaining information on the profile of the disc brakes acting face.
- Full profile scanning and analysis of the disc brakes acting face.
- Visualization of combined graphic images of the actual and new disc brakes profiles.



Real-time wheels geometry measurement system 3DWheel

The system is designed for non-contact automatic measurement of geometrical parameters of railway wheels and uses a combination of 2D laser scanners mounted wayside in the track area.

The system can be easily installed on any type of railway infrastructure.